

UNITED STATES  
DEPARTMENT OF LABOR  
MINE SAFETY AND HEALTH ADMINISTRATION  
COAL MINE SAFETY AND HEALTH

CAI-2001-20 through 32

REPORT OF INVESTIGATION  
Fatal Underground Coal Mine Explosions  
September 23, 2001

No. 5 Mine  
Jim Walter Resources, Inc.  
Brookwood, Tuscaloosa County, Alabama  
ID No. 01-01322

by  
Ray McKinney  
Administrator, Coal Mine Safety and Health, Arlington, VA

William Crocco  
Accident Investigation Program Manager, Arlington, VA

Kevin G. Stricklin  
Assistant District Manager, District 2, New Stanton, PA

Kenneth A. Murray  
Special Assistant to the Administrator, Arlington, VA

Stanley T. Blankenship  
Supervisory Special Investigator, District 5, Norton, VA

Roy D. Davidson  
Supervisory Safety and Health Specialist, District 5, Norton, VA

John E. Urosek  
Chief, Ventilation Division, Technical Support, Pittsburgh, PA

Clete R. Stephan  
Principal Mining Engineer, Technical Support, Pittsburgh, PA

Dennis A. Beiter  
Supervisory Mining Engineer, Technical Support, Triadelphia, WV

Originating Office  
Mine Safety and Health Administration  
Office of the Administrator  
Coal Mine Safety and Health  
1100 Wilson Boulevard  
Arlington, Virginia, 22209  
Ray McKinney, Administrator  
RELEASE DATE: December 11, 2002

## Table of Contents

OVERVIEW.....	1
GENERAL INFORMATION .....	2
EVENTS LEADING TO THE ACCIDENT.....	4
DESCRIPTION OF THE ACCIDENT .....	6
RESCUE AND RECOVERY OPERATIONS.....	17
INVESTIGATION OF THE ACCIDENT .....	22
DISCUSSION .....	22
Mine Management Structure.....	22
Training.....	23
Roof Control Plan.....	24
Geology .....	24
Fire Fighting and Evacuation Plan.....	27
Mine-Wide Monitoring System .....	28
Mine Ventilation Plan .....	29
Mine Ventilation .....	30
Methane Liberation .....	32
Ventilation Survey and Computer Simulations.....	32
Cleanup and Rockdusting Procedures.....	33
Mine Dust.....	34
Examinations.....	38
Electrical.....	39
Potential Ignition Sources .....	40
Origin, Flame and Forces .....	51
ROOT CAUSE ANALYSIS .....	58
CONCLUSION .....	62
ENFORCEMENT ACTIONS .....	63

## TABLES

Table 1 - Incidence Rates.....	3
Table 2 - MSHA Enforcement Actions During 2001.....	3
Table 3 - Stratigraphic Thickness Measurements .....	25
Table 4 - Outstanding 30 CFR 75.400 Violations.....	37
Table 5 - Alcohol Coke Test Results .....	57

## APPENDICES

- Appendix A - List of Injured Miners
- Appendix B - List of Persons Underground at the Time of the Explosions
- Appendix C - List of Mine Rescue Team Members
- Appendix D - List of Persons Who Provided Non-Confidential Voluntary Statements
- Appendix E - List of Persons Participating in Investigation
- Appendix F - Accident Investigation Data - Victim Information
- Appendix G - Chart - Mine Management Structure
- Appendix H - Mine Map - Active Underground Areas
- Appendix I - Mine Map - Approximate Locations of Underground Personnel at Time of First Explosion
- Appendix J - Mine Map - Approximate Locations of Underground Personnel at Time of Second Explosion
- Appendix K - Mine Map - Extent of Flooding During Recovery
- Appendix L - Mine Map - Affected Area of Mine - Portions of 2 East and Areas Inby
- Appendix M - Mine Map - Affected Area of Mine - Detail of 4 Section
- Appendix N - Mine Map - Affected Area of Mine - Detail of Area Surrounding End of 4 Section Track
- Appendix O - Mine Map - Affected Area of Mine - Detail of Area Surrounding 4 Section Switch
- Appendix P - Mine Map - Flame and Forces in Immediate Area Affected by First Explosion
- Appendix Q - Mine Map - Flame and Forces in Immediate Area Affected by Second Explosion
- Appendix R - Mine Map - Results of Testing on Mine Dust Samples
- Appendix S - Mine Map - Mine Ventilation
- Appendix T - Mine Map - Electrical Circuits, Electrical Equipment and Diesel Equipment Located in Areas of 3 East, 4 East and 4 Section
- Appendix U - Mine Map - Roof Characteristics in Affected Area
- Appendix V - Computer Simulation Model - Ventilation of 4 Section
- Appendix W - Computer Simulation - Ventilation of 4 Section After Roof Fall
- Appendix X - Computer Simulation - Ventilation of 4 Section After First Explosion
- Appendix Y - Computer Simulation - Ventilation of 4 Section After Second Explosion
- Appendix Z - Fan Shaft 5-7 Fan Pressure Recording Charts
- Appendix AA - Mine Electrical Equipment and Circuits Not Located Within the Explosion Origin Zones
- Appendix BB - 4 Section and 4 East High-Voltage Electrical Schematic Diagram
- Appendix CC - 4 Section Block Light Electrical Circuit Diagram
- Appendix DD - Selected Photographs - JWR No. 5 Mine

No. 5 MINE, MSHA ID No. 01-01322  
JIM WALTER RESOURCES, Inc.  
September 23, 2001

Immediate Area Affected by  
the Explosions

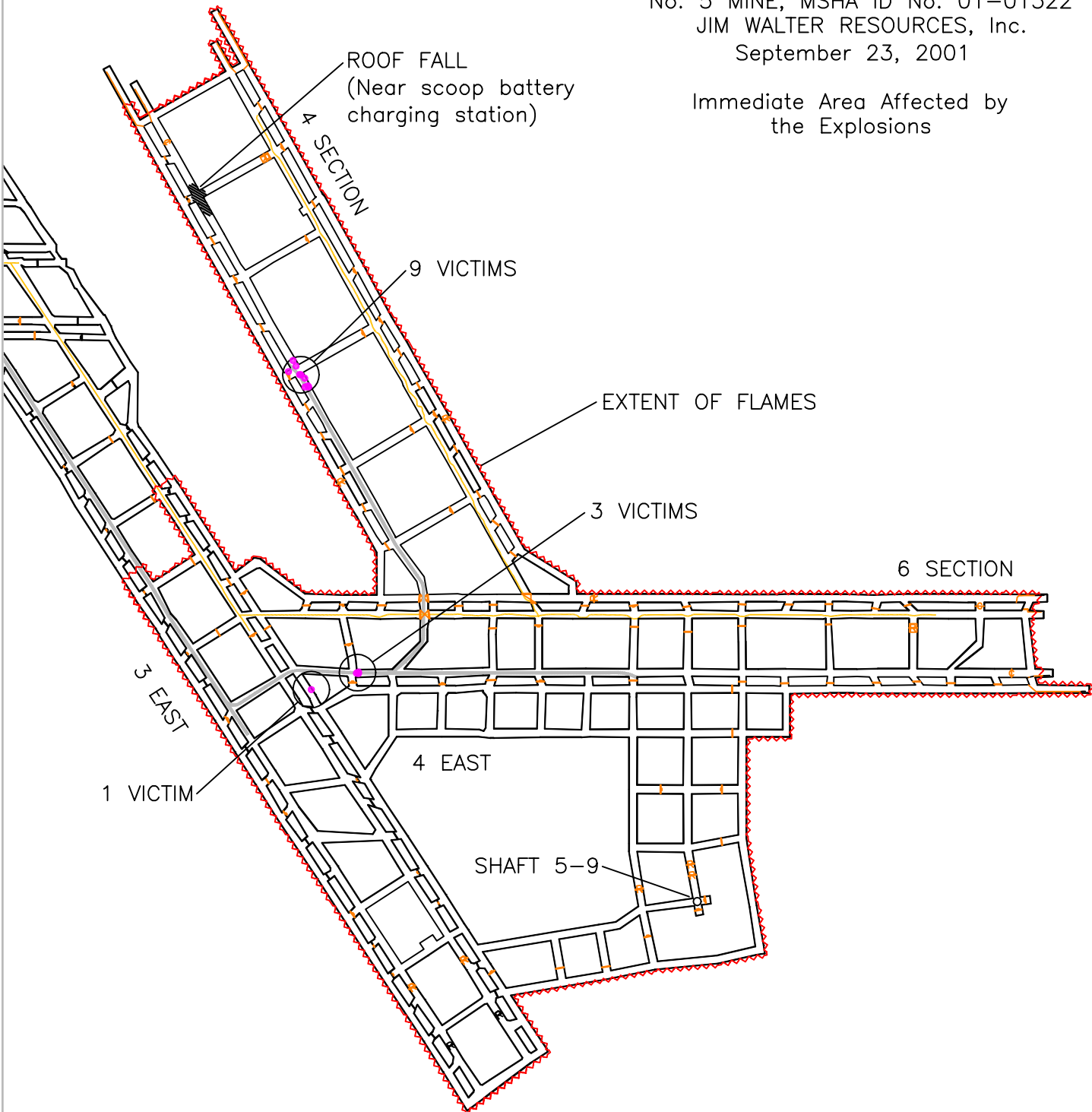



## **OVERVIEW**

On September 23, 2001, two separate explosions occurred at approximately 5:20 p.m. and 6:15 p.m. in 4 Section of the Jim Walter Resources, Inc., (JWR) No. 5 Mine, resulting in fatal injuries to thirteen miners. At the time of the explosions, thirty-two miners were underground during a non-producing Sunday afternoon shift. Appendices A and B list miners injured or fatally injured and miners underground at the time of the explosions, respectively.

Prior to the first explosion, three miners were building cribs to address deteriorating roof and rib conditions in the No. 2 Entry of 4 Section near the scoop battery charging station. A fourth miner was nearby delivering additional materials. A roof fall occurred at the intersection near the scoop battery charging station, releasing methane and damaging a scoop battery. A methane explosion occurred within minutes after the roof fall when an explosive methane-air mixture was ignited by arcing of the damaged battery. All four miners were injured. Three of the miners, including the section foreman, exited 4 Section. Due to the severity of his injuries, the fourth miner could not be moved from the section. He may have received fatal injuries. The explosion damaged critical ventilation controls. This disrupted the airflow and allowed methane to accumulate in 4 Section, including in the face areas and in the No. 2 Entry.

Miners de-energized the high-voltage electrical circuit for 4 Section shortly after the explosion. However, the track haulage block light system that extended into 4 Section remained energized. After communicating with the section foreman about the events in 4 Section, three other miners entered 4 Section to rescue the remaining injured miner. Additional miners from other areas of the mine were notified and traveled toward 4 Section to provide assistance. Five of these additional miners entered 4 Section. The miners who entered 4 Section traveled in the track entry through debris from damaged ventilation controls and encountered reversed airflow outby the end of the track. No handheld gas detectors were found near the miners in 4 Section. Four additional miners reached the mouth of 4 Section about the time the miners in 4 Section reached the end of the track.

The second explosion occurred when methane in the No. 2 Entry was most likely ignited by the block light system. The methane explosion propagated toward the faces of 4 Section, eventually involving coal dust. The explosion strengthened when additional methane and coal dust became involved near the intersection of the last open crosscut and the No. 3 and No. 4 Entries. The explosion, fueled primarily by coal dust, propagated outby through the No. 3 and No. 4 Entries into 4 East. The explosion continued into 6 Section, the Shaft 5-9 area and 3 East. The second explosion resulted in at least 12 fatalities and widespread destruction of ventilation controls throughout this area of the mine.

Nineteen miners exited the mine. Mine rescue teams were organized and a rescue effort was initiated. A mine rescue team found one severely injured miner and three deceased miners located outby the mouth of 4 Section. The injured miner was transported to the surface and arrived at 11:30 p.m. He died on September 24. On the morning of September 24, it was concluded that the missing miners could not have survived the effects of the explosions, and it became necessary to abandon the rescue due to a fire and other unsafe conditions. After lengthy recovery operations, the twelve remaining victims were recovered by November 8.

## **GENERAL INFORMATION**

The No. 5 Mine is an underground coal mine located approximately two miles north of Brookwood, Tuscaloosa County, Alabama. The mine was opened in 1977 and began production in 1979. It was connected with the JWR No. 4 Mine and was eventually isolated from the No. 4 Mine by seals in 1997. The mine has been owned and operated by JWR during its entire history. A map of the active areas of the mine is shown in [Appendix H](#). Principal officers were George Richmond, president and chief operating officer; Jesse E. Cooley, mine manager of No. 5 Mine; and Davis Trent Thrasher, deputy mine manager of No. 5 Mine. The operator developed and operated several other underground mines in the area, including the No. 4 Mine and the No. 7 Mine.

At the time of the accident, coal was produced with a longwall unit and two development units. The longwall had recently been moved to the H Panel where production began on about September 14. The longwall had retreated approximately 100 feet at the time of the accident. Continuous mining machines were used to develop 4 Section and 6 Section. The sections were developed with four entries. On 4 Section, the No. 1 and 4 Entries were section return air courses. The No. 2 Entry was the track haulage entry, the primary escapeway and intake air course. The No. 3 Entry was the belt haulage entry and functioned as an additional intake air course in 4 Section through a petition for modification of Title 30 Code of Federal Regulations (CFR) 75.350, which allowed belt air to ventilate the faces.

Development section equipment consisted of Joy 12CM-12 continuous mining machines and Jeffrey 4110 diesel Ramcars (trademark). The 4 Section utilized a Fletcher RR II-15-B CF roof bolting machine. The 6 Section was equipped with two Lee Norse TD43-2 roof bolting machines. At least one battery powered S&S 488 scoop was assigned to each section, as was a diesel powered forklift, CLA 5640N Lo Trac Utility Vehicle (Lo Trac). A Stamler BF-14 belt feeder was used at the tailpiece of the section belt conveyor coal haulage systems. Coal was transported from sections to the Production Shaft using belt conveyor systems. Detailed discussions of the electrical system, equipment, ventilation and roof control are included in this report.

During the first two quarters of calendar year 2001, mine production was reported as 523,210 and 546,459 tons, and total employment was reported as 388 and 390 persons, respectively. The miners were represented by the United Mine Workers of America (UMWA). At the time of the accident, the mine employee roster listed 334 hourly and 76 salaried employees, a total of 410. Of these, seven employees were on workers compensation or leave of absence.

Table 1 shows the Non-Fatal Days Lost (NFDL) and Overall incidence rates for the No. 5 Mine along with the comparable national rates for all underground coal mines. The Overall incidence rate is a compilation of the Fatal, NFDL, and No Days Lost (NDL) incidence rates. Preparation plant and office workers are excluded. The table shows the rates for the full year 2000 and for the first two quarters of 2001. The accident occurred during the third quarter of 2001.

Table 1 – Incidence Rates

Calendar Year	Quarter	Incidence Rate	No. 5 Mine	National
2000	1 through 4	NFDL	10.80	8.52
		Overall	14.39	11.11
2001	1	NFDL	5.66	7.00
		Overall	9.06	9.41
	2	NFDL	4.27	7.17
		Overall	5.34	9.76

A regular health and safety inspection (AAA) by the Mine Safety and Health Administration (MSHA) had begun on July 6, 2001, and was in progress at the time of the accident. The previous AAA inspection was completed on June 21, 2001. The last underground MSHA inspection activity at the No. 5 Mine was in 4 Section on September 20, 2001. Table 2 summarizes MSHA enforcement actions at the No. 5 Mine in 2001 prior to the accident.

Table 2 – MSHA Enforcement Actions During 2001

Type Enforcement Action	Number Initiated 1/1/01 to 9/23/01 (9 vacated actions excluded)
104(a) non-S&S citation	265
104(a) S&S citation	86
104(b) order	1
104(d)(1) citation	1
104(d)(1) order	1
107(a) order	5
103(k) order	6

At the time of the accident, 31 citations throughout the mine had not been terminated. Abatement of these citations was due prior to the accident. Twelve were cited under 30 CFR 75.400, Combustible Materials and Rock Dusting. Table 4 shows the corrective actions performed to address the conditions cited under 30 CFR 75.400. These citations and corrective actions are discussed in further detail in subsequent sections of this report.

## **EVENTS LEADING TO THE ACCIDENT**

During development, the mine roof at the survey station (SS) 13333 intersection in the No. 2 Entry of 4 Section was permanently supported with 72-inch fully grouted resin bolts and metal straps. This is the location where the roof fall later occurred. The roof and rib conditions in this area were not considered unusual. Small fractures or cracks were visible in the roof to some of those who examined the area. Similar small cracks in the roof were relatively common in all 4 Section entries throughout this general area. The amount of rib sloughage from the coal pillars was normal. Changes were not noticed in the conditions near the SS 13333 until the day shift on Friday, September 21.

Burt Duvall, section coordinator, was in 4 Section on the day shift of September 21. He heard a noise and saw a small crack in the roof and water dripping near the SS 13333 intersection. He instructed Greg Brown, section foreman, to have cable bolts installed through the intersection. About sixteen, 10-foot long cable bolts were installed during day shift through the SS 13333 intersection. Methane, water, broken coal and broken shale were encountered between 6 and 7 feet into the mine roof, while drilling the cable bolt holes. Competent roof was not encountered in the anchorage zone of many of the cable bolts.

During the afternoon shift of September 21, power was advanced and the belt was extended in 4 Section to the second crosscut outby the face. The power center was moved to the second crosscut outby the face. The scoop battery charging station was moved to the third crosscut outby the face, adjacent to the SS 13333 intersection. Both were located in the crosscuts between the No. 1 Entry and the No. 2 Entry. Michael Buchanan, section foreman on the afternoon shift, noticed water dripping from the roof at the SS 13333 intersection. Robert Tarvin and Steve Barnes, rockdusters; and Jerry Short, general laborer, rockdusted the belt extension between shifts.

Coal was produced in 4 Section on both the midnight and day shifts on Saturday, September 22. The midnight and day shift foremen both traveled through the mandoor in the stopping behind the scoop battery charging station. Water continued to drip from the roof. The foremen told investigators this was typical in some areas of the mine and they did not consider the roof in the area near SS 13333 to be adverse.

Coal was not produced in 4 Section on the afternoon shift of September 22. Buchanan was in charge of the non-producing shift maintenance work performed in 4 Section. He told investigators he did not detect any worsening condition in the area of the SS 13333 intersection. Jim Palmer, motorman, Short and Tarvin rockdusted the 4 Section belt on afternoon shift. According to testimony, they applied two tanks of rock dust to the entire belt entry. No personnel worked in 4 Section during the midnight shift on September 23 due to a scheduled main mine fan check. However, Albert (Jack) Dye, Jr., precision mason, conducted a preshift examination at the scoop battery charging station and the power center locations in 4 Section for the day shift prior to 5:15 a.m. He did not report any hazardous conditions. Dye noticed water dripping from the roof bolt holes approximately 30 to 40 feet outby the SS 13333 intersection.

The electrical power in the mine during the day shift on Sunday, September 23, was off intermittently due to a check of the high-voltage distribution system. The non-producing day shift crew for 4 Section, under the supervision of John Puckett, section foreman, entered the mine to perform maintenance work and to roof bolt the faces after the power was restored. At the start of the shift, Puckett noticed water dripping from roof bolts near the SS 13333 intersection. Puckett saw no deformation of the roof bolt bearing plates that would have indicated movement of the roof. David Terry, roof bolting machine operator, told Puckett water had begun dripping from the roof on Thursday or Friday and cable bolts had been installed in the area.

Puckett issued work assignments to the miners. Electricians Isaac Smith and Jeffrey Jarrell repaired oil and water leaks on the continuous mining machine, which was located in the No. 2 Entry near the power center. Terry and Johnny Sealy, roof bolting machine operator, moved supplies to the newly established supply hole using the Lo Trac. The new supply hole was located across from the scoop battery charging station in the crosscut between the No. 2 and No. 3 Entries.

Puckett spent the majority of his shift in 6 Section. He returned to 4 Section at approximately 1:30 p.m. and began a preshift examination. The roof bolters were still moving supplies. Puckett noticed the left rib of the No. 2 Entry in by the SS 13333 intersection was sloughing as he traveled to the faces. The roof bolters told Puckett the ribs had been sloughing periodically throughout the shift. Puckett traveled to the faces and continued his preshift examination.

Electrical power was restored to 4 Section at approximately 1:30 p.m. About that time, I. Smith heard a popping sound from the area near SS 13333. He walked back and noticed the stopping behind the scoop battery charging station was damaged due to convergence. I. Smith thought the noise might have been from the stopping being damaged and returned to the continuous mining machine. Puckett traveled into the No. 1 Entry to measure the airflow and noticed sloughage on the yield pillar in by the scoop battery charging station. He also noticed the stopping behind the scoop battery charging station was cracked and damaged due to convergence. A small hole had developed in the stopping. Puckett showed Sealy the damaged stopping and commented that cribs needed to be built in the No. 2 Entry. Puckett called Duvall, who was in the mine office, and informed him of the sloughing ribs and the damaged stopping. Puckett told Duvall cribs were needed to protect the yield pillar and the stopping needed to be rebuilt before mining operations could be resumed.

Puckett told the electricians to move the continuous mining machine into the No. 1 Entry. This permitted access for the scoop to be used on the afternoon shift to clean the sloughage in the No. 2 Entry before building cribs. Puckett called Dave Blevins, afternoon shift outby foreman, to verify that the message about needing crib blocks had been relayed to Blevins. I. Smith told Puckett about the popping noise he heard earlier. Puckett and some of the miners looked at the area near SS 13333 again. He inspected the area, showed them the crack in the roof, and told the miners cribs were going to be built on afternoon shift in the area. The volume of water dripping from the roof had increased during the shift.

Tony Key, afternoon shift section foreman for 4 Section, arrived at the mine at approximately 2:00 p.m. and met with Duvall in the mine office. Duvall informed T. Key that he had spoken with Puckett and the yield pillar was sloughing in the area of the scoop battery charging station. T. Key received the preshift examination report call from Puckett, who again discussed the roof conditions at the SS 13333 intersection. Puckett recalled telling T. Key about rib sloughage and the condition of the stopping but did not recall saying the top was working. However, T. Key recalled being told the top was working and recorded "top working" in Puckett's preshift examination report. Puckett later signed the preshift examination record without making any corrections to the recorded information. Duvall gave T. Key a map with instructions to build cribs in all four corners of the SS 13333 intersection and on five-foot centers on both sides of the No. 2 Entry from the scoop battery charging station to the power center.

### **DESCRIPTION OF THE ACCIDENT**

The afternoon shift on September 23 began at approximately 3:00 p.m. Duvall gave Milton Wren, day shift CO Room supervisor, a list showing the number of people assigned to different underground areas. Thirty-two persons worked underground during the afternoon shift, four of whom were supervisors. The remaining 28 people were hourly employees. Wren entered the information into the computer log. Harry House, night shift CO Room supervisor, was to begin his 12-hour shift at approximately 5:00 p.m. and was expected to update and close out the log when the afternoon shift concluded.

T. Key was to supervise the work activities in 4 and 6 Sections. Mike McLe, longwall machine helper, and Gaston Adams, longwall machine operator, were to install cribs near the SS 13333 intersection. Dennis Mobley and Charles Nail, electricians, were to perform equipment maintenance on both 4 and 6 Sections. Palmer was to transport roof support supplies to 4 Section. Tarvin, Short, and John Knox, motorman, were to rockdust the belt entry in Sub Main B from the No. 6 stopping outby to the belt header. Benny Franklin, longwall foreman, was to supervise the maintenance work activities on the longwall. Charles Ogletree, longwall machine operator helper, and Jimmy Dickerson, general laborer, were to perform maintenance on the longwall. George Corbin, electrician, who had worked day shift performing maintenance on the longwall, was to join them later in the shift. Sammy Riggs, precision mason, and Charles Smith and Terry Stewart, general laborers, were to work on stopping construction in H Panel Tailgate.

Christopher Key, fireboss/pumper, Clarence Boyd, shearer operator, and Nelson Banks, Jr., electrician, were to install a water pump at the 2 East Sump. After installing the pump at the 2 East Sump, C. Key and Boyd were to get a pump from along the 2 East track near the longwall panel to replace a faulty pump in Sub Main B. Banks was also to assure the circuit breakers were set at each of the belt starters. Tom Connor and Alvin Bailey, general laborers, and Lonnie Willingham, scoop operator, were to construct frames for a seal in the F Panel Headgate area. Gene Robertson, belt foreman, was to supervise belt work on the 1 East and 2 East belts. Stewart Sexton, general laborer, and Ricky Rose and Wendell Johnson, belt repairmen, were to check and replace the belt splices, as necessary, on 1 East belt. Robertson assisted Joe Sorah, Vonnie Riles and Raymond Ashworth, belt repairmen, and Bill Hallman, general laborer, who were to repair a section of the 2 East belt. Randy Jarvis, general laborer, was to travel in the longwall bleeder

entries to examine the water pumps. He was to also examine the power center and pumps in H Panel Tailgate. Blevins was to begin his shift at the bottom of the Service Shaft. He normally did this in the event one of the crews needed additional supplies sent to their work area.

The personnel assigned to 4 and 6 Sections were delayed for approximately 40 minutes due to the track being blocked on Big Fault Hill. Puckett was on one of the last manbuses to arrive at the Service Shaft bottom. T. Key and Puckett briefly discussed the roof conditions in the area of the scoop battery charging station in 4 Section before the afternoon shift crew traveled to 4 Section.

### The Roof Fall

T. Key and his crew arrived in 4 Section shortly after 4:00 p.m. and left the manbus near the end of the track. T. Key examined the roof as he walked inby in the track entry. He stopped and could hear the roof cracking and creaking and saw trickles of coal falling off the ribs in places. Small rocks that had fallen from the roof were visible on the mine floor. A small slip was visible in the roof extending diagonally across the track entry at the SS 13333 intersection and into the crosscut toward the No. 1 Entry. The top appeared to be working all the way out to the slip. Both McIe and T. Key saw water dripping from the roof.

Puckett had told T. Key he observed indications of roof movement at some roof bolts in the area of SS 13333. Although T. Key saw no excess roof movement as indicated by the roof bolts, the other conditions he observed indicated that the extent of the deteriorating roof conditions were greater than had been described by Puckett. T. Key instructed Adams to start building cribs about 60 feet outby the SS 13333 intersection.

T. Key traveled into the supply hole crosscut and observed the roof was not working in that location. He then looked into the scoop battery charging station and observed that the stopping showed signs of convergence. It was cracked and had developed a hole. As usual, a curtain had been hung at the entrance of the scoop battery charging station to direct airflow into the crosscut. A scoop battery had been hung from roof bolts on chains and the charging cables were connected to the battery but the charger was not energized. Meanwhile, McIe retrieved the Lo Trac from the supply hole and began to transport the four bundles of crib blocks from the supply car at the end of the track to the area to be supported. T. Key then traveled inby one crosscut to the power center where sloughage of the left rib was visible. The conditions appeared to be worsening. T. Key gave a trenching shovel to Adams to use in building cribs and proceeded into the face areas of the No. 1 Entry and the No. 2 Entry. The last cut at the face of the No. 2 Entry was not bolted and a test for methane indicated 0.3 to 0.4% methane. The methane concentration at the face of No. 1 Entry was 0.3%. The continuous mining machine was in the No. 1 Entry near the last open crosscut and was to be moved to the face in preparation for coal production on the midnight shift.

Returning from the face of the No. 1 Entry, T. Key met Nail and Mobley, who had come to move the continuous mining machine. Nail energized the continuous mining machine and it was moved into the face of the No. 1 Entry. McIe had already brought up some crib blocks and Adams was in the process of building the first crib. At approximately 4:20 p.m., T. Key called Blevins from

the telephone at the power center to tell him the stopping behind the scoop battery charging station would need to be replaced before production resumed in 4 Section.

T. Key then traveled to the last open crosscut, where he met Nail and Mobley again. He sent them to 6 Section to repair the feeder and instructed them to leave the section through the belt entry to avoid the area of SS 13333 intersection. T. Key traveled from the last open crosscut into the No. 1 Entry to check the stopping behind the scoop battery charging station and observed that the stopping was continuing to converge. The hole in the stopping had enlarged to about four square feet. Wood posts on the return side of the stopping, remaining from the temporary ventilation control originally installed there, were cracked and broken. T. Key noticed a slip in the roof extended from the crosscut into the No. 1 Entry. He traveled outby in the No. 1 Entry to the next mandoor to re-enter the No. 2 Entry.

At approximately 4:30 p.m., T. Key returned to the site where Adams had just completed building the first crib on the left side of the entry. T. Key and Adams began building the second crib on the right side of the No. 2 Entry across from the first crib while McIe continued to transport the remainder of the crib blocks. Palmer arrived in 4 Section and waited for McIe to finish unloading the crib blocks before meeting Nail and Mobley at the manbus.

Palmer changed out with Nail and Mobley's manbus and returned to the end of 4 Section track. McIe finished unloading the crib blocks and parked the Lo Trac in the intersection outby Adams and T. Key. McIe helped finish building the second crib. T. Key, Adams, and McIe worked together until approximately 5:15 p.m. to complete the third crib about five feet inby the second crib on the right side of the No. 2 Entry.

The roof conditions in the No. 2 Entry worsened as small rocks began falling and water began pouring steadily from the roof. Several loud bumps were heard as T. Key, Adams and McIe backed up a few steps. At approximately 5:17 p.m., they heard sounds indicating possible roof bolt breakage. A large rock fell from the roof and then the roof in the entire intersection fell.

T. Key could not see the battery or charger, and thought the battery could be under the fallen rock. McIe, Adams and T. Key walked to the crosscut outby the fall and got a drink of water. T. Key decided the electrical power to the section needed to be de-energized and also decided to call the CO Room to report a major roof fall so MSHA could be notified. T. Key told McIe and Adams about his plans, turned and took a few steps outby. McIe and Adams walked from the crosscut into the No. 2 Entry. Palmer was near the end of the track coupling the empty supply car to the locomotive.

### *The First Explosion*

At approximately 5:20 p.m., T. Key heard loud noises that sounded like explosive shots being detonated as the first explosion occurred. T. Key was picked up by a blast of air and blown outby, losing his hard hat and cap lamp. T. Key was struck in the back by debris and was injured. McIe was blown outby and lost his hard hat and cap lamp while sustaining burns and other injuries. Adams received substantial injuries as a result of the explosion forces. Palmer was also



injured as he was blown off his feet and rolled down the track entry, losing his cap lamp and hard hat.

Ventilation was disrupted and suspended dust made breathing difficult. T. Key donned his self-contained self-rescuer (SCSR) for a short period of time. He heard Adams say his back was injured and he could not move. McIe told T. Key his ribs and head were injured. McIe was able to find Adams who still had a cap lamp. He borrowed Adams' cap lamp with the intention of getting help, however, the dust was so dense the light from the cap lamp was barely effective. T. Key made his way to McIe who donned an SCSR. T. Key's handheld gas detector alarm activated intermittently but he did not check to see which gas caused the alarm. He could hear the diesel locomotive running at the end of the track. T. Key and McIe locked arms and began walking toward the sound of the locomotive by following a cable in the track entry.

The effects of the explosion varied in other areas of the mine. [Appendix I](#) shows the approximate locations of personnel underground when the first explosion occurred. In 6 Section, the concussion of air was significant enough to damage stoppings, as later noted by Nail and Mobley. They left 6 Section in their manbus and traveled toward 4 Section to investigate. They left their manbus on the 4 East track inby the two supply cars Palmer had brought in and walked into 4 Section. Tarvin, Short and Knox, preparing to rockdust in the Sub Main B belt entry, felt a small concussion and believed a stopping had been compromised. Knox went to his locomotive in the track entry, uncoupled it from the two rock dust tanks parked at the second stopping in Sub Main B, and headed inby to investigate. Tarvin and Short continued with preparations for rockdusting. Tarvin later walked back to the rock dust tanks and waited for Knox to return.

At 127 Shield on the longwall face, the longwall maintenance crew was in the process of replacing a relay bar when the explosion occurred. Ogletree heard a loud noise while Franklin and Dickerson felt their ears pop. Franklin, Dickerson and Ogletree believed there was a roof fall in the longwall gob and continued working. Corbin, who had recently arrived in H Panel Headgate, was walking around the stageloader when he felt his ears pop. He thought a roof fall in the longwall gob had occurred and proceeded across the face. Bailey, Connor, and Willingham, who were working in the F Panel Headgate area, heard something that sounded like someone had gone through a mandoor and let the door slam.

In the CO Room, approximately five minutes after the explosion, the computer printout recorded the communication failures that occurred at three system monitoring addresses located in 4 Section and 4 East. These communication failures were the result of damage caused by the forces of the first explosion.

In 4 Section, even though the locomotive lights were on, the dust was so dense T. Key and McIe could not see the locomotive as they walked toward it. They walked past a Ramcar parked inby the end of the track and bumped into the empty supply car. At the locomotive, Palmer was getting up off the floor and moved toward McIe. There was less suspended dust near the locomotive. T. Key decided he should telephone the surface to request help for Adams and to report the explosion. He continued walking outby, past Palmer, without a cap lamp. McIe told

Palmer what had happened and they needed to get out. McIe and Palmer picked up T. Key on the locomotive at approximately 5:30 p.m. and the three men continued outby.

Dust was raised into suspension by the explosion in other areas of the mine. Dust reached the location where Tarvin and Short were working in the Sub Main B belt entry. In the longwall area, light dust progressed down the longwall face where the longwall maintenance crew assumed that the rock dust crew was rockdusting the belt entry and continued working. Jarvis, walking in the bleeder entries behind the longwall, noticed some dust in the bleeder airflow passing over him. Jarvis believed the dust was caused by rockdusting outby and continued walking his route. In F Panel Headgate, Bailey, Connor, and Willingham noticed visible dust for a few minutes but continued working after the dust cleared.

In 4 Section, the debris from ventilation controls, damaged by the forces of the explosion, slowed Palmer, McIe, and T. Key's exit on the locomotive. T. Key saw two cap lamps coming toward them, got off the locomotive and walked out to meet the men. Nail and Mobley met T. Key inby the overcasts at the mouth of 4 Section and told him that the locomotive could not go much further because the return overcast was damaged and blocked the track. They also told T. Key stoppings in 6 Section had been damaged. Palmer and McIe came out on the locomotive to where T. Key, Nail, and Mobley were talking. After reaching the severely damaged overcast where concrete blocks and I-beams were down across the track, Palmer shut off the locomotive.

T. Key instructed Nail to make sure the electrical power was turned off to 4 Section at the vacuum breaker. The visual disconnects at the vacuum breaker were opened, which de-energized the high-voltage electrical circuit to 4 Section.

T. Key noticed the intake air entering 4 Section was short circuited into the 4 East return air course at the damaged overcasts and observed that the 4 East belt was visible through the damaged belt overcast. Mobley and T. Key walked outby to find a telephone to call outside. They met Knox who had traveled to the mouth of 4 Section on his locomotive. T. Key told Knox what happened and that he wanted to get to a telephone to report the situation to the CO Room. Mobley and T. Key boarded the locomotive with Knox and traveled outby to a telephone located at the 3 East turn. Knox told T. Key he had tried the telephone on the way to 4 Section and it did not work. While T. Key tried to call out on the telephone, Knox traveled to another telephone in the area to contact someone on the surface.

In the bleeder entries, Jarvis reached the water pump and initialed the date board at approximately 5:35 p.m. Although he was scheduled to monitor the water pump, he proceeded out of the bleeder entries because of the dust in the air. He traveled by manbus out of the longwall section to the tailgate of the longwall in anticipation of conducting his assigned preshift examination.

At approximately 5:45 p.m., T. Key contacted House in the CO Room from the telephone at 3 East turn. T. Key told House a roof fall had occurred and, shortly thereafter, an explosion occurred and damaged a return overcast at the mouth of 4 Section and stoppings in 6 Section. He told House miners were injured, Adams was down, and emergency help, ambulance and Lifesaver helicopter services were needed. The telephone apparently malfunctioned and the communication

between House and T. Key was interrupted. T. Key's back was hurting and he lay in the area by the telephone. House could tell by the telephone caller ID number that T. Key was not calling from 4 Section and knew he was at an outby telephone, but could not determine his location. House tried to contact T. Key with a mine-wide page but T. Key did not hear the page, even though he remained near the telephone. Knox returned and told T. Key the other telephone did not work. Knox and Mobley told T. Key they were going to 4 Section to rescue Adams.

While looking for the telephone numbers of the ambulance service, House began a mine-wide page for Will Tanniehill, afternoon shift haulage foreman, and Robertson. House was not aware Tanniehill was not working. Unable to locate the ambulance service telephone numbers, House called 911 at 5:48 p.m. The 911 call was received by the Tuscaloosa County Sheriff's Office and a three-way call was initiated with the North Star Paramedic Services in Tuscaloosa, Alabama. House informed them an ignition and fire had occurred at the No. 5 Mine and men were down. House called Lifesaver for a helicopter.

House continued the mine-wide page for Tanniehill and Robertson. Blevins, still at the Service Shaft bottom, answered the page and informed House that Tanniehill was not working that shift. House reportedly told Blevins a roof fall and an explosion had occurred on either 4 Section or 6 Section and people were down. House told Blevins to go there and help. However, through interviews with others, it appeared Blevins was initially under the impression an ignition and/or fire had occurred. Evidence indicates Blevins did not mention anything about an explosion to other personnel. At approximately 5:50 p.m., Blevins left the bottom on a manbus and traveled toward 4 Section while House continued the mine-wide page for Robertson.

While Short waited in the Sub Main B belt entry, the airflow became very dusty. Short notified Tarvin about the dusty conditions. Both men thought something was wrong and decided to find a telephone to call outside.

At 127 Shield on the longwall face, the dust seemed to be getting thicker. The longwall maintenance crew decided to retreat to the headgate and try to find fresh air in the intake entry. When they arrived at the intake entry, it became apparent the dust was not coming from rockdusting in the belt entry. Because of the dusty conditions, Franklin directed the crew to leave. As the longwall maintenance crew was leaving, the dust in the air appeared to worsen.

Johnson, who was working on the 1 East belt with Sexton and Rose, responded to the page for Robertson and called House. House thought he was talking to Robertson and stated that he told Johnson there was a roof fall and an explosion on 4 Section or 6 Section, people were down, and for them to go there to help. However, Johnson reportedly told Sexton and Rose that House told him there had been an ignition in 4 Section, there were some people hurt, they had a fire, and he wanted every available man to help. Johnson, Sexton, and Rose completed the belt splice they had been working on and traveled to the 2 East belt to get the other belt crew members. Meanwhile, Knox and Mobley traveled on a locomotive to the 4 Section switch and walked inby to where they met Palmer, McLe and Nail. McLe told Knox there had been a roof fall, that Adams was hurt, and where Adams was located. Knox told McLe and Palmer they should leave the mine because of their injuries. At approximately 5:55 p.m., Knox, Nail and Mobley traveled into 4

Section through the debris from the damaged overcasts. It appears the locomotive Palmer left in by the damaged overcasts was driven to the end of 4 Section track by Knox, Mobley and Nail.

McIe and Palmer walked outby to the locomotive at the 4 Section switch and coupled the locomotive to the two supply cars that blocked the manbus on the 4 East track. Palmer wanted to move the supply cars to allow the manbus to be used to transport Adams from the area.

In the CO Room at this time, House called Thrasher at his residence and informed him T. Key had reported a roof fall and an explosion. House was not sure if the incidents occurred in 4 Section or 6 Section. He told Thrasher he was sending miners to the area, that miners were injured and there was damage to ventilation controls. He also told Thrasher he was trying to make contact with the other crews underground. Thrasher traveled to the mine.

C. Key, Boyd, and Banks had completed their work at the 2 East Sump. Banks had left and traveled in by on his manbus to check whether the electrical power was reset at all belt drives. C. Key and Boyd left shortly thereafter and traveled toward the longwall area in 2 East to get a water pump. C. Key and Boyd saw Tarvin and Short at the 459 switch. Shortly before 6:00 p.m., Palmer and McIe left the 4 Section switch and traveled outby on a locomotive with the two supply cars.

Near the 2 East belt header, Sexton went into the belt entry to tell Robertson and the other belt crew members (Ashworth, Sorah, Riles and Hallman) about the situation. They were in the process of removing a section of damaged belt. Sexton told Robertson they had been paging for him and that Johnson had answered the page. Sexton relayed Johnson's conversation to the other crew members. After some discussion, they decided not to finish completing the belt repair and to respond immediately. Robertson told Sexton to pick him up by the 2 East belt starter box. Ashworth, Sorah, Riles and Hallman went to the manbus with Sexton. Robertson walked the belt entry to the 2 East starter box to turn off the remote switch. Sexton drove the manbus back to the 2 East belt starter box and waited for Robertson. Some miners on the manbus had discussions about how far away they were from 4 Section and how the conditions might worsen before they arrived.

Before 6:00 p.m., House called Cooley, who was not at the mine, and told him there had been a roof fall and an explosion in 4 Section. Cooley asked him if he was sure it was not an ignition. House replied there was an explosion with stoppings and an overcast damaged. House also reported some miners were injured and on their way out of the mine while another miner, Adams, was still in 4 Section. House also reported that other miners were going in to help, that he had notified the other people in the mine and they were coming out, and that he had notified emergency services and mine rescue personnel. Cooley told House he would be there as soon as possible. Although House told Cooley that miners were evacuating the mine, investigators found no indication that any miner was notified to evacuate at this time.

Just after House spoke with Cooley, Tarvin called House from the telephone at the F Panel Headgate switch to ask if a failed ventilation control had been reported. House confirmed there had been a failed stopping reported and to clear the track because there were injured miners.

Because of past derailing problems at the 459 switch, Tarvin decided to take the rock dust tanks to the rock dust hole.

Dale Byram, JWR manager of safety and training, who was off-site, received a call from the Brookwood Fire Department. He called the CO Room and spoke with House. House told Byram there had been an explosion, some ventilation controls had been damaged, and men were injured. Byram activated the mine rescue callout system.

C. Key and Boyd met Riggs, Stewart and Smith between G Panel and H Panel in the 2 East track entry. Riggs told C. Key there had been an ignition in 4 Section and he was going to help. Both manbuses traveled out of 2 East. C. Key followed Riggs into Sub Main A on the 459 track. Banks traveled into Sub Main B on his manbus ahead of Riggs.

At the 2 East belt header, Robertson came out to the track and got onto the belt crew manbus with Sexton, Rose, Riles, Ashworth, Hallman, Johnson, and Sorah. They headed inby toward 4 Section. Some of the men on the manbus expressed reservations about going into 4 Section to fight a fire when they were so far away from that location.

Tarvin and Short, driving toward the rock dust hole, met Blevins who told them to park their locomotive and rock dust tanks at the Car Wash. Blevins backed outby past the Car Wash switch and the rockdusters followed.

On the way out of 3 East, Palmer and McIe saw T. Key at the 3 East turn. They stopped and picked him up and continued out of Sub Main B. They saw lights approaching and continued toward the E Panel switch.

Although their activities are not known for certain, it is likely that it was approximately 6:00 p.m. when Knox, Mobley and Nail reached Adams and started toward the end of the 4 Section track with him.

At the Car Wash switch, Tarvin and Short parked the locomotive and rock dust tanks. As Blevins instructed, Tarvin and Short took two fire extinguishers from the locomotive and got on the manbus with Blevins. As Blevins started inby toward 4 Section, the belt crew manbus arrived behind them but there was no communication between the persons on the two manbuses. Sexton followed Blevins through the 459 switch toward Sub Main B.

At E Panel, T. Key got off the locomotive and threw the switch so Palmer could back the locomotive and supply cars into the E Panel track spur. The first manbus to arrive was driven by Banks. Riggs, Smith and Stewart pulled up behind Banks at the switch. Banks left the switch and drove his manbus toward 4 Section. It is not known what information Banks knew about the accident in 4 Section before arriving at the E Panel switch, nor what he learned before traveling inby. C. Key and Boyd rode up behind Riggs, Stewart, and Smith at E Panel. T. Key was lying against the rib next to the switch while Palmer was sitting on the locomotive and McIe was standing beside the locomotive. T. Key told C. Key there had been a rock fall and Adams was trapped in 4 Section. Boyd got off C. Key's manbus and talked to McIe who told Boyd that

Adams was hurt, where Adams was located, and who else was in 4 Section. Riggs and the others with him said they were going in to help. Boyd told C. Key he was going to help and C. Key replied that he was going to take the 3 injured men out. Boyd got on the manbus driven by Riggs along with Smith and Stewart, and they continued inby. C. Key helped T. Key into the front of the manbus and helped Palmer and McIe into the back of the manbus. It was approximately 6:05 p.m. as C. Key left the E Panel switch with the three injured men.

In the CO Room, House received a telephone call from someone underground who had spoken with T. Key. The person told House that T. Key told him to report an overcast was out on the 4 Section track. Between telephone calls with other persons, House initiated another mine-wide page for Blevins to inform him about the damaged overcast but he never made contact with him.

The longwall crew stopped at the telephone at the H Panel Tailgate switch and Franklin spoke with House to inquire about the dust. House told Franklin there was a problem and asked if he had all of his men with him. House told Franklin to exit the mine with his crew and anybody else he encountered. According to other testimony, Franklin told his crew there had been an explosion in 4 Section and suggested they go into 4 Section to see if they could help. A miner expressed reservations about going into 4 Section. Before traveling toward the 459 switch, Franklin's crew de-energized power to the longwall headgate at the power borehole vacuum breaker.

House had just hung up from his telephone call with Franklin when he received a call from Thrasher, who was en route to the mine. Thrasher asked House if he had contacted the other underground crews and if they were on their way out of the mine. House replied that he had talked with them and everybody was on their way out of the mine. However, investigators determined that only Franklin's crew was told to evacuate the mine when they contacted the CO Room. Franklin was also told to evacuate any other miners he encountered. In addition, a mine-wide page had not been activated to evacuate miners underground.

In Sub Main B, the airflow in the track entry was dusty as Blevins approached the D Panel switch. When Blevins saw C. Key's manbus approaching him, he stopped and walked over to C. Key's manbus to talk with T. Key. T. Key told Blevins that Adams was hurt in 4 Section. Shortly after Blevins stopped at the D Panel switch, Sexton drove the belt crew manbus behind Blevins' manbus. The three manbuses were in a line on the Sub Main B track as Sexton got off the belt crew manbus and walked over to T. Key. Robertson got off the belt crew manbus and walked over just as the conversation between Blevins and T. Key was ending.

Blevins told the miners gathered there to get the manbuses into the D Panel track spur so the injured men could get to the bottom. Hallman got off the belt crew manbus and threw the D Panel switch so the manbuses could be put into the D Panel track spur. Riles and Blevins stood by the switch and discussed the fact they could see and smell smoke coming from inby. Blevins told C. Key to take the injured men to the bottom and told Robertson, standing nearby, there could be a bad situation in 4 Section. Robertson suspected a fire in 4 Section might have been getting out of control. Blevins got on his manbus in the D Panel track spur and waited for C. Key and the injured men to pass. When C. Key drove his manbus up to the switch, several others walked over and briefly spoke with them. C. Key asked Blevins to make sure there were medical

personnel on the surface to treat the injured miners and then left for the bottom with McJe, Palmer and T. Key.

There were many independent conversations about the conditions that existed in 4 Section with different information being shared. Some people were told a roof fall had occurred, Adams was injured, and Knox, Nail and Mobley were with him. Some were told there had been an explosion. Some were told a scoop battery was on fire while others may have been told there was the chance of a second explosion. Blevins knew miners had been injured and believed there was a fire in 4 Section.

At approximately 6:10 p.m., Banks, Riggs, Smith, Boyd, and Stewart arrived at the 4 Section switch and started walking into 4 Section. They traveled in the track entry through the debris from the damaged ventilation controls and encountered reversed airflow outby the end of the track. Since no handheld gas detectors were found near the miners in 4 Section, it is likely they made no tests for methane. In the CO Room, House received a telephone call from Cooley concerning the status of the situation. House told Cooley the injured people were on the way out, there were people going to help Adams, and the other people were being evacuated from the mine.

At the D Panel switch, Blevins said smoke may be encountered before reaching 4 Section and SCSRs might be needed for miners to work their way into 4 Section and fight a fire. One miner got off Blevins' manbus and said he would not wear an SCSR to fight a fire. A second miner also got off the manbus and Blevins asked for three volunteers to accompany him. Ashworth, Sorah, and Johnson got on Blevins' manbus. Blevins told Robertson and the remaining people with him to wait there for three or four minutes before coming into 4 Section. Blevins told Robertson to call the CO Room to let them know the injured men were coming out, and to make sure they had ambulances coming for them. Blevins headed toward 4 Section with Ashworth, Sorah and Johnson while Tarvin, Short and Hallman waited at the D Panel switch for Robertson to return. Rose drove Robertson, Sexton and Riles outby toward the telephone located at the F Panel Headgate switch.

The manbus carrying the longwall crew arrived at the 459 switch where Franklin again discussed assisting the people who were hurt in 4 Section when the block light system alerted them traffic was approaching from Sub Main B. It was C. Key and the injured miners exiting the mine. Shortly thereafter, the block light came on again and Robertson's manbus arrived at the 459 switch. The men on the two manbuses exchanged information and Robertson and Franklin walked over to the telephone at the F Panel Headgate switch where Robertson called the CO Room to make sure ambulances would be available.

Although the following activities in 4 Section are not known for certain, it is likely Knox, Mobley and Nail had brought Adams back to the end of the track. Banks, Riggs, Smith, Stewart and Boyd had just reached the area and were walking along the side of the locomotive. In 4 East, Blevins, Johnson, Sorah and Ashworth had just arrived near the 4 Section switch and stopped behind Riggs' manbus. Blevins left the manbus and began walking inby toward the 4 Section switch. It

appears Sorah and Johnson moved into the other seat on the inby side of the manbus facing outby and Ashworth may have gotten off the manbus.

### The Second Explosion

At 6:15 p.m., the second explosion occurred in 4 Section when methane in the No. 2 Entry was most likely ignited by the block light system. [Appendix T](#) shows the approximate location of the 4 Section block light. The methane explosion propagated toward the faces of 4 Section, eventually involving coal dust. The explosion strengthened when additional methane and coal dust became involved near the intersection of the last open crosscut and the No. 3 and No. 4 Entries. The explosion, fueled primarily by coal dust, propagated outby through the No. 3 and No. 4 Entries into 4 East. The explosion continued into 6 Section, the Shaft 5-9 area and 3 East. [Appendix J](#) shows the approximate locations of personnel underground when the second explosion occurred. The miners in 4 Section received fatal injuries. Near the 4 Section switch, Blevins, Sorah and Johnson received fatal injuries. Ashworth received severe injuries and traveled outby toward the 3 East track.

Almost all of the miners who were underground felt or saw the effects of the second explosion. At the D Panel switch, Tarvin, Short and Hallman were blasted by air and knocked into the crosscut. Hallman's handheld gas detector alarmed but he could not read the instrument display because of the dense dust cloud. After a short period of time, the alarm ceased. Tarvin, Short and Hallman talked about donning their SCSR's but decided not to as long as there was just dust in the air. Eventually, they were able to find the track as they held onto each others' belts and worked their way back to the 459 switch area. The longwall and belt crews felt a surge of air and heard a loud blast as the air reversed at the 459 and F Panel Headgate switches. Those standing were either knocked down or fell to the ground because of the blast of air. The air was filled with thick dust. Ogletree and Dickerson got off the longwall manbus and joined Riles, Rose and Sexton on the belt crew manbus and traveled outby to exit the mine. Corbin made his way toward Franklin and Robertson at the F Panel Headgate switch telephone where they discussed the situation.

About halfway down Big Fault Hill, T. Key and C. Key felt their ears pop as they continued toward the bottom. In H Panel Tailgate, Jarvis was sitting in his manbus when he heard a rumble and felt his ears pop and noticed that the air reversed for a short period of time before returning to its original direction. Jarvis thought the noise and changes in airflow were caused by the failure of an overcast at the mouth of H Panel Tailgate and the air became filled with thick dust. Jarvis called the CO Room and asked House what happened. House told Jarvis to come out of the mine but Jarvis decided to leave the area and go outby looking for what he believed was a damaged overcast.

In F Panel Headgate, Connor, Bailey and Willingham were sitting on a supply car near the end of the track where they heard what sounded like a big roof fall and mandooors slamming. The airflow reversed and then returned to its normal direction. The air was filled with thick dust and while waiting for the dust to clear, they could hear House paging for Blevins. Connor called the CO Room to find out what happened. House told Connor he did not have time to explain what



happened but that Connor needed to exit the mine immediately. Connor, Bailey and Willingham, then exited the mine. At F Panel Headgate switch, Franklin, Robertson and Corbin left for the bottom on Franklin's manbus after deciding to exit the mine and get a mine rescue team. It was approximately 6:20 p.m.

At approximately 6:25 p.m., T. Key, C. Key, McIe and Palmer reached the surface. T. Key, McIe and Palmer were taken by ambulance to the hospital. Shortly thereafter, Tarvin, Short and Hallman reached the telephone at the F Panel Headgate switch. Tarvin called the CO Room and told House there had been an explosion. House told Tarvin everybody should get out and to tell Blevins to call the CO Room. Tarvin informed House that Blevins had already gone inby and was probably in 4 Section. Tarvin, Short and Hallman started walking toward the bottom as House began another mine-wide page for Blevins.

A number of CO alarms from various locations in the mine activated and were recorded by the CO Room computer printout. The water gauge alarm for the Fan Shaft 5-7 fans activated. These alarms were acknowledged by the CO Room operator.

As Tarvin, Short and Hallman were walking, they met Jarvis and told him what had happened. They all exited the mine in his manbus and before 7:00 p.m., Jarvis, Tarvin, Short and Hallman had reached the surface. Although a mine-wide evacuation was not initiated after either explosion, nineteen miners safely exited the mine. Thirteen miners (Adams, Knox, Nail, Mobley, Banks, Riggs, Boyd, Stewart, Smith, Blevins, Johnson, Sorah and Ashworth) were missing.

## **RESCUE AND RECOVERY OPERATIONS**

There were three distinct phases of rescue and recovery operations. The initial response began prior to the second explosion. Some miners who were underground responded individually, while others did so under the direction of mine management, as previously discussed in the accident description. During the initial phase, three of the four miners who were injured during the first explosion safely evacuated the mine. The second explosion ended the initial rescue operation. [Appendix F](#) contains victim information data sheets.

Terry Langley, MSHA District 11 Hueytown, Alabama, field office supervisor, was notified about an explosion at the No. 5 Mine by Randy Clements, UMWA safety committeeman, at approximately 6:00 p.m. Langley called the mine and spoke with House. House told Langley a big ignition or an explosion had occurred in 4 Section and some miners were injured. At approximately 6:05 p.m., Langley notified Frank Young, MSHA District 11 manager, who notified MSHA headquarters personnel. MSHA's Mine Emergency Unit (MEU) and Technical Support were subsequently notified and dispatched to the mine site.

After the egress of the remaining uninjured miners, the rescue and recovery operation entered a second phase. Senior company officials arrived at the mine and took charge of the operation. Information about the conditions and persons still underground was gathered by questioning those who had escaped from the mine. From the information obtained, it was evident a second explosion had occurred. It was determined there were 13 missing miners. The mine fans were

monitored and the results routinely communicated to the CO Room. Access to the mine property was secured. MSHA issued a 103(k) Order upon arriving at the mine. The command center was established with representatives from JWR, the UMWA, the State of Alabama's Office of Safety and Inspection, and MSHA.

Two mine rescue teams were assembled. Mine Rescue Team No. 1 entered the mine through the Service Shaft at approximately 8:05 p.m. [Appendix C](#) lists the mine rescue team members who participated in the rescue and recovery operation. The team communicated with the command center at designated check points as they traveled inby in two manbuses. The team stopped and checked the air quality in the return at the bottom of Fan Shaft 5-7 and measured 20.1% oxygen, 0.7% methane, and 160 parts per million (ppm) carbon monoxide (CO). They also terminated the mine power near the bottom of Intake Shaft 5-8. It was approximately 8:45 p.m.

They traveled into the 459 track. At the first set of overcasts, the team smelled smoke they believed was from a wood fire and stopped. The belt overcast at that location was damaged. A gas test taken in the belt entry revealed 21% oxygen, 0.0% methane, and 16 ppm CO. A grey colored dust covered the belt and track entries in the area. Three sets of footprints were visible in the dust in the track entry. The team returned to the F Panel Headgate telephone and called the command center to inquire about the footprints. It was verified the footprints were those of Hallman, Tarvin and Short, who had walked out from D Panel switch after the second explosion.

The team continued slowly inby in the manbuses, testing for gas as they advanced without donning breathing apparatuses. The grey dusting became heavier as they proceeded into Sub Main B. More significant effects of the explosion forces were encountered inby the E Panel in Sub Main B where several ventilation controls had been damaged. Some debris had to be removed by hand to continue advancing with the manbuses. The rescue team reached the 3 East turn and attempted to call the command center from the telephone located there. Unsuccessful, the team returned to the telephone at the F Panel Headgate switch and called the command center to report their findings. It was approximately 10:05 p.m. Continuing back into 3 East, the rescue team saw the stoppings between the belt entry and the track entry had been blown out by the forces of the explosion.

On the surface, a rescue truck with an escape capsule had been sent to Shaft 5-9. It was decided to lower an escape capsule into Shaft 5-9 in the event any miner reached the shaft bottom. Cap lamps and radios had been placed in the escape capsule and the capsule was lowered at 10:10 p.m. A third rescue team had been assembled at the mine office.

Mine Rescue Team No. 1 continued on the manbuses into 4 East, moving debris as they advanced. About 2 crosscuts into 4 East, the amount of material in the track entry prohibited the manbuses from going any further. Shortly thereafter, the mine rescue team found Ashworth sitting along the rib about 50 feet south of the track entry near SS 12710. Ashworth was conscious but could not communicate with the rescue team members. While some rescue team members attempted to stabilize Ashworth, the others continued inby in the 4 East track entry, searching for the remaining missing miners.

Sorah and Johnson were found fatally injured in a manbus, one crosscut in by the location where they had found Ashworth. Two of the team members explored in by to the area of the 4 Section switch and found two additional manbuses. They continued in the 4 Section track entry to the 4 East belt overcast. They found the overcast destroyed and the debris blown out by toward the 4 Section switch. A test for gas out by the damaged overcast indicated the air was clear. The team members could not see beyond the damaged overcast because the dust that covered the area made objects indistinguishable.

Two rescue team members transported Ashworth out of the mine. Ashworth arrived on the surface at 11:30 p.m. and was transported via Lifesaver helicopter to the hospital where he expired on September 24. The remaining team members, aware the emergency hoist and radios were to be lowered to the bottom of Shaft 5-9, decided to travel there. They hoped to find survivors and intended to establish communications with the surface by radio. The radios were found underwater on the floor of the escape capsule. Communications could not be established. There were no miners found in the area of Shaft 5-9. Most of the ventilation controls were destroyed. The team then traveled from the shaft bottom toward the 4 Section switch. Approaching the manbus that contained the two victims, a team member stumbled over a miner's belt. A handheld gas detection instrument was with the belt. The three persons already found were wearing belts. The team again searched the area for another person. A fourth victim, Blevins, was found fatally injured under the manbus in which Johnson and Sorah were found. Subsequent investigative mapping of the area surrounding the 4 Section switch is detailed on the mine map in [Appendix O](#). The team left the area and rode their manbus out to the telephone at F Panel Headgate and communicated their findings to the command center. It was 12:05 a.m. on September 24.

Based on the information received, personnel in the command center decided the 6 Section area of the mine held the best hope for the survival of the remaining missing miners. The rescue team was directed to explore the 6 Section area. As the team advanced into 6 Section in the track entry, they passed by the main airstream flowing north from Shaft 5-9. A short distance in by SS 13096, they encountered a layer of smoke near the roof in the track entry that was rolling back against the airflow. The rescue team donned their breathing apparatuses. The stoppings located between the belt entry and the track entry were destroyed. Air quality tests indicated 0% methane, 20% oxygen, and 50 ppm CO. The rescue team continued in by to the next intersection, SS 13103, and found bundles of crib blocks burning in the crosscut between the belt entry and the track entry. Airflow was passing over the team and moving toward the fire. A decision was made to attempt to extinguish the fire and continue searching for the missing miners.

The team was aware the water line in the belt entry was severed where they parked the manbuses, so they searched for fire extinguishers. Two fire extinguishers were found and used in an unsuccessful attempt to extinguish the fire. Team members began searching for the 6 Section emergency supply sled, which should have contained additional fire extinguishers. Advancing another two crosscuts in the track entry, the team found no air movement. The team then retreated to fresh air and discussed the situation. Lacking the necessary materials to fight the fire, the team decided to update the command center. An inventory of the materials needed to re-

assemble the water line was made as the team returned to the manbus. The team rode outby to the telephone at F Panel Headgate.

Meanwhile, Mine Rescue Team No. 2 was advancing communications toward 3 East. The two rescue teams met outby the 3 East turn and communicated with the command center. The time was approximately 2:00 a.m. The teams received permission from the command center to fight the fire with water. The two rescue teams worked together to re-establish the water line by gathering fire hose and re-assembling the damaged water line. The communication line and fresh air base were advanced to the 3 East turn. They lacked about 800 feet of line to reach the fire. A manifold needed to connect the fire hose to the water line could not be found.

The teams returned to the fresh air base telephone at the 3 East turn to call the command center and inform them of the needed supplies. Some team members continued to advance the communication line into 3 East while others worked outby to correct intermittent telephone communication problems. Mine Rescue Team No. 3 was sent underground to relieve Mine Rescue Team No. 1. After Mine Rescue Team No. 3 reached the fresh air base, the command center instructed Mine Rescue Team No. 1 to exit the mine at 5:27 a.m. At approximately 6:00 a.m., Mine Rescue Team No. 1 reached the surface. Mine Rescue Team No. 2 began exploration work in the belt entry and left return entry of 6 Section and at the mouth of the 4 Section. All the ventilation controls across the mouth of 4 Section were destroyed. They found airflow into the No. 3 Entry (belt) and the No. 4 Entry (right return) of 4 Section from the No. 1 Entry (left return) of 6 Section. Light smoke was visible and gas tests detected 21% oxygen, 0.5% methane and 50 ppm CO.

Mine Rescue Team No. 2 found heavy smoke in the airflow exiting the No. 1 Entry of 4 Section. Gas tests revealed 3.1% methane, 162 ppm CO and 20.3% oxygen. They returned to the fresh air base and called the command center to report their findings. At approximately 6:25 a.m., a decision was made to evacuate everyone from the mine. All personnel who were underground reached the surface by 7:09 a.m. on September 24. The mine rescue teams were debriefed. It was concluded the missing miners could not have survived the effects of the second explosion. The conditions prevented the safe re-entry to recover the victims.

The second phase of the mine rescue and recovery operation was concluded. One of the thirteen missing persons had been rescued and three of the remaining twelve persons had been found. Plans were developed to complete the recovery operation and the third phase of the rescue and recovery operation began.

On September 24, a decision was made to extinguish the fire and to isolate the suspected explosion area from the remaining mine workings by flooding the area inby 3 East. Water was pumped into the mine through Shaft 5-9 beginning on September 25. The dip of the coal seam resulted in 3 East, 4 East and 6 Section being flooded while the inby portion of 4 Section remained above the water level. The portion of the mine map contained in [Appendix K](#) shows the extent of the mine that was flooded. A vertical borehole was drilled into the No. 2 Entry of 4 Section at the last open crosscut. Degasification pumps were connected to the borehole to exhaust the methane that accumulated in the area. The borehole exhaust was monitored to

evaluate the mine atmosphere inby the water in 4 Section. Pumping operations were completed on September 29.

Multiple mine rescue teams, composed of trained mine rescue personnel from JWR, the State of Alabama, and other nearby mines, were assembled. A list of mine rescue teams and members is shown in [Appendix C](#). On October 2, mine rescue personnel re-entered the mine. With the exception of portions of the bleeder entries made inaccessible by water accumulation, the mine was explored and re-ventilated to the edge of the water in 3 East. Concerns about spontaneous combustion in the inaccessible areas of the mined-out longwall panels resulted in a decision to seal F Panel and G Panel before continuing with the recovery efforts. Sealing of the mined-out panels was completed on October 12.

A plan was developed to advance from the 3 East turn into 4 Section in stages as the water was pumped out of the mine through Shaft 5-9. Sets of temporary seals were used to maintain a non-explosive atmosphere within the area not yet explored. On October 15, four temporary seals were constructed outby the edge of the water across the 3 East entries. The atmosphere inby and outby the temporary seals was continuously monitored to insure the safety of the mine rescue teams. Rockdusting and necessary repairs to ventilation controls in the area of the mine outby the temporary seals were completed prior to pumping the water from behind the temporary seals. On October 20, the removal of the water began. Water removal was coordinated with the advancement of the temporary seals and construction of temporary ventilation controls.

By November 3, all of 4 Section had been dewatered and the temporary seals advanced to just inby the mouth of 4 Section. The area of the 4 Section switch was ventilated. Three victims (Sorah, Johnson, and Blevins) were recovered and brought to the surface at approximately 1:52 p.m. on November 3. A decision was made to rock dust portions of 3 East inby to 4 Section switch prior to any further exploration. The rockdusting was completed during the day shift on November 7.

On the afternoon shift, November 7, a mine rescue team explored into 4 Section. By 5:40 p.m., the nine remaining victims were found near the end of the 4 Section track, near SS 13303. Temporary seals were constructed across the entries of 4 Section inby the location of the victims. On November 8, the area where the victims were located was ventilated. The nine victims (Adams, Nail, Mobley, Knox, Banks, Riggs, Stewart, Smith and Boyd) were recovered and brought to the surface at 11:50 p.m. Subsequent investigative mapping of the area surrounding the end of the 4 Section track is detailed on the mine map in [Appendix N](#).

On November 13, mine rescue personnel explored the remainder of 4 Section. The scoop battery located under the roof fall at the scoop battery charging station was partially exposed but not safely accessible. The battery was covered with a cementitious foam to isolate it from the mine atmosphere prior to re-ventilating the area. The remainder of 4 Section was ventilated on November 17.

On November 21, water pumping operations began removing the remaining water from 6 Section and the area around the bottom of Shaft 5-9. Ventilation controls were constructed underground

to control the airflow entering into the mine through Shaft 5-9 when the water seal was broken. The water seal was broken on November 24. Ventilation changes were made to permit Shaft 5-9 to function as an intake shaft. Extensive rehabilitation of the mine inby 3 East was necessary. As rehabilitation progressed, coal production was resumed in the completed areas.

## **INVESTIGATION OF THE ACCIDENT**

The Administrator for Coal Mine Safety and Health directed an investigation be conducted by a team consisting of personnel from MSHA Coal Districts 2, 5, and 6; personnel from Headquarters, Coal Mine Safety and Health; personnel from the MSHA's Pittsburgh Safety and Health Technology Center; and personnel from the Office of the Solicitor, Department of Labor. Ray McKinney, MSHA District 5 manager at the time of the accident, was assigned as the accident investigation team leader.

The investigation team members arrived onsite and began the investigation on October 1. Preliminary information and records were obtained from the MSHA District 11 office in Birmingham, AL, and from the mine operator. Mine personnel were identified for interviews. Witness interviews were conducted in Birmingham and Brookwood, Alabama. Subsequently, 76 interviews attended by the MSHA investigation team and representatives of JWR, the UMWA and the State of Alabama were conducted with personnel who had relevant knowledge. Confidential interviews were also conducted. Other contacts were made and information was obtained from contractors, and state and local authorities. Pertinent records were obtained and reviewed during the course of the investigation. Physical evidence was examined or tested as necessary. Samples collected during the course of the investigation were analyzed and evaluated.

[Appendix D](#) is a list of persons interviewed on a non-confidential basis and [Appendix E](#) lists the persons who participated in the investigation. Underground investigative procedures included mapping of the affected areas. [Appendix L](#) depicts evidence recorded in portions of 2 East and the areas inby. Specific areas of 4 Section, the end of the 4 Section track, and the 4 Section switch, are detailed in Appendices [M](#), [N](#) and [O](#), respectively.

## **DISCUSSION**

### **Mine Management Structure**

The management structure at No. 5 Mine was nontraditional. Rather than the traditional direct line supervision structure of mine manager, superintendent, mine foreman, and foreman, the No. 5 Mine management was structured under an "area manager" concept. Area managers reported to the mine manager and deputy mine manager. Area managers supervised coordinators. First line supervisors, such as section foremen, reported to coordinators. A chart showing the mine management structure is shown in [Appendix G](#).

Four area managers at the mine were responsible for the development sections, longwall, outby areas, and preparation plant. The deputy mine manager also acted as the operations planning manager supervising the shop coordinator, planning supervisor, electrical engineer, and senior



plant engineer. The industrial relations supervisor and the safety supervisor reported to the deputy mine manager. Each area manager supervised a single coordinator, except for the outby area manager, who supervised three coordinators, one each for haulage, belts, and general services.

The division of responsibility under the area manager/coordinator structure was unclear to some production foremen and miners. From a safety perspective, the division of responsibility within the management structure, as well as rotation of personnel, sometimes yielded an undesirable result. For example, the 4 Section No. 1 Entry was cited by an MSHA inspector on September 20, for float coal dust accumulations. While the section foreman may have been able to begin immediate abatement actions, he was unaware of the violation. Instead, the responsibility for abatement of the violation went to the outby area manager. The practice of not providing a management representative who was able, during inspections, to redirect resources to rapidly abate violations may not have always been efficient.

The structure of the safety program at the mine was also nontraditional. The safety department consisted of a salaried supervisor. In addition, four hourly miners traveled with inspectors and performed independent inspection-type activities in surface and underground areas. Deficiencies identified during independent inspection-type activities were documented in written work orders. These work orders were forwarded to the safety department supervisor and were entered into the computerized database system for action by the appropriate area manager. Once corrective action was completed, a notation was made on the work order and the computer database was updated. Numerous work orders were produced and entered into the system. The majority of work orders involved minor maintenance-related issues. Comparatively few safety issues such as accumulations of coal dust, float coal dust, and excessive methane, were identified under this system.

## **Training**

As part of the investigation, training records were reviewed for all underground and surface miners who worked the afternoon shift of September 23. Approved Part 48 training plans with lesson plans and training materials used to conduct training were also reviewed. Instructors at the JWR Brookwood Training Center (BTC) conducted annual refresher training, electrical, diesel and other specialized miner training at the training center site. Experienced miner training was started at the BTC and completed at the mine with a mine tour and specifics of mine training. The JWR safety supervisor conducted this mine site training for No. 5 Mine. Management and labor personnel conducted task training at the mine.

Part 48 training was recorded on MSHA form 5000-23 and MSHA Approved Alternate form 5000-23 for Annual Refresher Training and Task Training. JWR received separate MSHA approvals for use of these alternate forms on December 21, 1998 and May 11, 2001 respectively.

The review indicated the training conducted for miners met the requirements of Part 48. Deficiencies were not found in Part 48 training or in maintenance of training records.

## **Roof Control Plan**

The approved Roof Control Plan allowed the use of the following type roof bolt systems as a minimum means of primary roof support: mechanically anchored tensioned roof bolts; fully grouted resin roof bolts; or tension/rebar combination roof bolts. “Single-seam mining” is a local term that indicates only the Blue Creek coal seam is mined, leaving the middleman and the Mary Lee coal seam as the immediate roof. When middleman thickness was in the 30-inch to 72-inch range, the minimum bolt length was 60-inches. When a thicker middleman was present, the minimum bolt length was 48-inches. Entries and crosscuts were permitted to be developed a maximum of 24-feet wide with roof bolts installed in a maximum of five feet by five feet bolting pattern. Entry and crosscut centers ranged from a 40-foot minimum to a 360-foot maximum. The primary roof support used in 4 Section consisted of 72-inch long, fully grouted, No. 7 J-bars installed in 1-inch diameter holes in conjunction with six-inch by six-inch flat bearing plates. In many locations, 14-gauge steel straps were also used.

The 4 Section was a four-entry longwall development section conducting single seam mining. The section was developed utilizing a yield-stable-yield pillar design to enhance ground control in future tailgate and future bleeder entries. The 4 Section was developed in a N30°W direction. The No. 4 Entry was to be the tailgate for the longwall panel; the No. 1 Entry and No. 2 Entry were eventually to function as bleeder entries. Prior to the accident, the No. 3 Entry served as the belt conveyor entry for the section development.

Yield pillars in 4 Section were nominally 20-foot wide with lengths ranging from 70 to 200 feet. The stable pillars were nominally 220-foot wide with lengths ranging from 220 to 270 feet. Entries and crosscuts were typically mined 20 to 21-foot wide. However, rib sloughage on the section resulted in actual widths of 22 to 24 feet. Typical mining height on the section was approximately 7 feet.

Supplemental roof support, in the form of 10-foot long, 0.6-inch diameter, non-tensioned cable bolts with a 4-foot grouted length, was installed in various areas. The number of cable bolts per row varied, either two or three, as did the distance between rows.

## **Geology**

The rock strata over the Blue Creek coal seam included a middleman of silty shale, an upper coal seam (Mary Lee), and a main roof of sandy shale and sandstone. The middleman and the Mary Lee coal seam were exposed in various areas in and around 4 Section. Due to safety concerns, a direct measurement of stratigraphic thickness in the SS 13333 intersection roof fall area was not possible. However, stratigraphic measurements taken at five other locations in the area are listed in Table 3.



Table 3 – Stratigraphic Thickness Measurements

Location	Middleman Thickness	Mary Lee Thickness
One crosscut inby the 4 East Switch at SS 12711	7.3 feet	10 inches
4 Section Belt Drive at SS 13038	6.5 feet	10 to 12 inches
Six crosscuts inby 4 Section Switch at SS 13078	6.5 feet	12 to 18 inches
Return overcast site, located three crosscuts north of Shaft 5-9 at SS 13110	7 feet	12 inches
Roof fall cavity in No. 4 Entry of 4 Section at SS 13314	6 feet	12 to 16 inches

Roof characteristics, such as falls and discontinuities, which were observed in the affected area are shown on the mine map in [Appendix U](#).

In addition to these measurements, information was provided by the operator for two test holes in 4 Section drilled and examined with a stratascope on August 31, 2001. The log of the first test hole, drilled in the No. 1 Entry between SS 13317 and SS 13339, indicated the middleman was 6.5-feet thick and the Mary Lee coal seam was 1-foot thick. The log of the second test hole, drilled in the No. 3 Entry between SS 13320 and SS 13340, indicated the middleman was 4.8-feet thick and the Mary Lee coal seam was 2.2-feet thick.

#### Discontinuities

Discontinuities were observed in each of the four entries of 4 Section and in the No. 1 Entry and No. 2 Entry of 6 Section. Based on the orientation determined with a hand transit, a distinct relationship between the discontinuities of the two sections was identified. A thick coating of dust or soot on the ribs and roof of 4 Section tended to obscure fine scale features, including tight joints and fractures. However, joint segments, affected by fresh spalling or small offsets and apertures, were readily observable. Joint orientation was predominately northwest with a sparsely occurring subordinate northeast set.

#### Roof Falls

Two roof falls were examined in 4 Section and, in both cases, the failure zones were intersected by jointing. The first roof fall in the No. 2 Entry, at the scoop battery charging station, occurred approximately 360 feet outby the face and measured approximately 90-feet long by 52-feet wide. The fall spanned the intersection and extended into the crosscut in both directions. The height of the fall cavity was approximately 25 feet above the original roofline. Observing the fall area from the crosscut between the No. 2 Entry and No. 3 Entry, the main roof above the Mary Lee was visible in cross section along prominent jointing. This main roof was delaminated, forming roughly one-foot-thick slabs in the upper portion of the cavity and 3-foot-thick slabs in the lower portion of the cavity. The approximate thickness of the middleman and Mary Lee were 5 feet and

12 to 15 inches respectively, as measured at both the inby corner of the long-block crosscut and the outby edge of the fall in the No. 2 Entry.

The second roof fall, located approximately 760 feet outby the face in the No. 4 Entry, occurred in the 3-way intersection near SS 13314. This fall was discovered on November 24, during ongoing recovery activities. The height of the fall cavity was approximately 15 feet above the original roofline while the maximum width spanned the No. 4 Entry. Fall length was approximately 55 feet. The Mary Lee coal seam was 12 to 16-inches thick and the middleman was 6-feet thick at this location.

In addition, a roof failure referred to as a middleman fall, located approximately 590 feet outby the face of the No. 4 Entry, occurred in the 3-way intersection near SS 13318. The roof fell prior to the installation of primary roof supports. The fall spanned the width of the entry and measured 12 feet in length by approximately 6 to 7 feet in height. The outby brow of the fall cavity had sagged, resulting in a horizontal separation of several inches, between the top of the Mary Lee and the base of the main roof.

#### *The Roof at the SS 13333 Intersection*

During development, the intersection was permanently supported with 72-inch fully grouted resin bolts and metal straps. The roof and rib conditions in this area were not considered unusual. Changes were not noticed in the conditions until the day shift on Friday, September 21. A small crack in the roof was observed, a noise was heard, and water was dripping from some roof bolt holes. About sixteen, 10-foot long cable bolts were installed during day shift on Friday. Methane, water, broken coal and broken shale were encountered above the anchorage zone of the primary roof supports (72-inch fully grouted resin bolts). Competent roof was not encountered in the cable bolt anchorage zone of many of the cable bolt holes.

During drilling of the cable bolt holes, the potential seriousness of the condition was not accurately determined by those working in 4 Section and thus, was not fully communicated to the section coordinator. A change in the conditions in the intersection became evident on day shift on Sunday, September 23. The conditions progressively deteriorated throughout the shift. Sloughage of the ribs increased, water flow increased and noises associated with ground movement increased. Roof movement occurred as evidenced by the developing cracks and convergence on the posts and stopping in the crosscut adjacent to the intersection. At the end of day shift, the section foreman called out a preshift report identifying further deterioration of the mine roof. Plans were made to install cribs on the afternoon shift. The section foreman on the afternoon shift Sunday, September 23, found the condition had further deteriorated requiring the installation of cribs over a larger area. Continued convergence on the stopping in the crosscut adjacent to the intersection resulted in irreparable damage. Arrangements to replace the stopping were made. The roof continued to deteriorate during the installation of the cribs and it eventually fell.

## **Fire Fighting and Evacuation Plan**

The Fire Fighting and Evacuation Plan was approved on July 22, 1999. The plan stated, in part, the following: the person at the manned location on the surface shall be trained in the operation of the CO monitoring system and in proper procedures to follow in the event of an emergency; a supervisor or designated person will assemble all men promptly and lead the way during the evacuation; and fire drills, as required, will be conducted on all three shifts. The regulations in 30 CFR 75.1101-23 require all miners to participate in fire drills at intervals of not more than 90 days. The operator had also developed a handbook titled "#5 Mine CO Room Supervisors Responsibilities Procedures and Telephone Numbers" that was used by the CO Room supervisors. It included managing communication duties by knowing the locations of area managers and coordinators, as well as other key people, vital to the operation of the mine. It required the operator to gather information when problems, such as accidents, ignitions, etc., occurred and obtain help if needed.

A proper evacuation procedure was not followed after the first explosion in 4 Section. Miners were not immediately evacuated from the mine after an explosion damaged critical ventilation controls. These conditions were known by, and communicated to, management personnel. The section foreman, T. Key, believed there was a possibility of a second explosion. He may not have communicated the information in an effective manner to other miners. Although his handheld gas detector was in alarm, the reason for the alarm was not determined. It should be noted the section foreman was injured. He did convey to the CO Room supervisor that a roof fall and explosion had occurred and ventilation controls were damaged. As the injured section foreman was leaving the section and being transported to the surface, he discussed the conditions in 4 Section with a number of miners.

After being told of the explosion, the CO Room supervisor did not conduct a mine-wide page to evacuate personnel from the mine. He instead paged only Tanniehill and Robertson to make them aware of the situation. Even though the CO Room supervisor said he had a list of personnel that were working underground, he was unaware that Tanniehill was not working until Blevins told him. Blevins, still at the Service Shaft bottom, answered the page. House instructed Blevins to travel to 4 Section to provide assistance.

Miners from other areas of the mine responded to the emergency in 4 Section believing either an ignition or a fire had occurred. These miners were unaware an explosion had occurred and a second explosion was possible. Management knew personnel were already in 4 Section to rescue Adams but failed to evacuate all other miners from the mine. Miners underground were not alerted to the problem through the mine-wide telephone paging system. Some miners were instructed to evacuate only after they called the CO Room to find out if there was a problem because of the dust or concussion they had felt.

At the D Panel switch, Blevins met other miners and asked for volunteers to go to 4 Section, informing them SCSRs might be needed to fight a fire. SCSRs are only intended to be used for evacuation purposes.

Gas detection equipment was not found on any of the miners in 4 Section or during the underground investigation of 4 Section. Gas detection equipment is essential to determine the composition of the atmosphere and secure the safety of those entering unknown atmospheres, especially when damaged ventilation controls are encountered. Miners traveling in the No. 2 Entry of 4 Section would have encountered reversed airflow and explosive concentrations of methane.

The operator failed to conduct fire and emergency drills at intervals of not more than 90 days. Interviews of underground miners and a review of mine records indicate that no such drills had been conducted since March, 2001. The lack of training and simulation relative to proper evacuation procedures to be followed in the event of an emergency affected the miners' response to the emergency situation of September 23.

### **Mine-Wide Monitoring System (MWMS)**

The MWMS included three computers located on the surface in the CO Room and multiple surface and underground sensors. The Master Control Program (MCP) was the only computer necessary for the system to function. The other two computers were added to the system to provide access to information the system collected that was not required by granted petitions for modification. The types of information the MWMS monitored included CO levels, belt functions, power status, point type heat sensor status, oxygen levels, Fan Shaft 5-7 fan operation, water level, and emulsion pressure.

#### *Alarms and Events*

Preset values or conditions at specific addresses within the system were established to activate alarms. An alarm condition resulted in both visible and audible notification of the CO Room supervisor that an alarm condition had been detected. The audible alarm was sounded in the CO Room. The visual notification occurred on a computer screen available to the CO Room supervisor. The alarm notification for CO concentrations was set to activate in the CO Room below the required alarm level. Manual acknowledgement of the alarm condition by the CO Room supervisor resulted in the audible alarm being muted. However, visual notification remained until the condition cleared. The system provided information (alarm description, history interval, alarm settings, events attached to the alarm, current value) for the active alarmed addresses that could be accessed by the CO Room supervisor. The locations of the underground sensors were shown on a map located in the CO Room. The MCP automatically generated a printed report of alarms, events, and other predetermined information gathered by the system. This printout was generated in the CO Room and was available to the CO Room supervisor.

Use of the MWMS was required in a petition for modification of 30 CFR 75.326 (renumbered as 30 CFR 75.350) that had been granted for the No. 5 Mine. The petition enabled belt entries to be used as additional intake air courses to ventilate the working faces. A responsible person was to be stationed within sight or sound of the alarm system at all times. The responsible person was required to be trained in the operation of the CO detection system and also in the proper procedures to follow in the event of an emergency. The ambient CO level specified in the

approved mine ventilation plan was 5 ppm. Carbon monoxide levels exceeding 10 ppm above the ambient level were required to initiate fire alarm signals at both the working section and the manned location on the surface. Thus, the alarm level was 16 ppm CO. An alert level of 11 ppm CO activated an alarm only in the CO Room.

#### System Operation on September 23, 2001

Information from multiple underground and surface sensors was received by the MCP and recorded on the computer printout on September 23. Audio and visual alarms were activated by the system in the CO Room and alerted the CO Room supervisor to the alarm conditions. Pertinent information was recorded on the CO Room printout.

The data on the printout provided information about the actions of persons and events that occurred. Control functions indicated when specific belts were operated and when power was removed. The first explosion caused damage to the MWMS and resulted in an interruption in communication between the MCP and sensor locations: the New 4 Section - P/C and Drive; the 4 East Belt CO Box at Tailpiece; and the New 4 Section Outstation. Communication errors with these three sensor locations were reported by the MWMS approximately 5 minutes after communication ceased.

Both explosions caused damage to ventilation controls that resulted in decreases in the operating pressure of the Fan Shaft 5-7 fans. The decrease in operating pressure, which occurred as a result of the second explosion, was sufficient to cause an alarm. Additional damage to the MWMS also resulted in interrupted communications between the MCP and three other sensor locations: the 4 East Belt Outstation Functions; the 4 East Belt Power Center/Drive CO; and the 4 East Belt Outstation Point Heat Sensors. Communication errors were reported by the MCP approximately 5 minutes after communication ceased. The airflow traveling from 3 East to Sub Main B, 2 East, and the H Panel Headgate carried gases from the explosion. Alarms in the CO Room occurred when CO concentrations in excess of 11 ppm reached various sensors in the belt entries of those areas.

#### **Mine Ventilation Plan**

The Ventilation Plan in effect was approved on February 28, 2001 and included a number of addendums that were part of the plan. The plan addressed specific requirements for the continuous mining machine development sections, which included 4 Section. At least 20,000 cubic feet per minute (cfm) of air was required to reach the faces of all places where coal was cut, mined, or loaded with line curtain being maintained within 10 feet of the face. When extended cuts were being taken, a minimum of 21,500 cfm of air was required behind the line curtain at the last row of permanent roof support. A minimum of 6,000 cfm of air was required at the end of the line curtain during roof bolting and servicing cycles with at least 3,000 cfm required in all other faces. A minimum of 15,000 cfm was required in the last open crosscut of each split.

The plan specified that a trickle rockdusting machine would be operated in the ventilation split where coal was being produced. If the trickle duster was inoperable, the scoop-mounted

rockdusting machine would be used to blow at least 10 bags of rock dust into that ventilation split before each working place was mined on that split.

The plan addressed specific requirements for the longwall. A minimum air velocity of 600 feet per minute was required along the longwall face. A minimum quantity of 55,000 cfm of air was required at the No. 10 Shield, mid-face, and tailgate when coal was being mined. A minimum quantity of 55,000 cfm of air was to be directed to the longwall face from the headgate entries.

The plan also addressed the hazards associated with spontaneous combustion in the F and G Panels. These requirements included additional examinations in the bleeder entries, continuous monitoring for CO, and additional water lines for cooling of heated areas.

Portions of the bleeder entries for the G and H Panels had deteriorated to the point it was unsafe to travel the entries in their entirety. A supplement to the ventilation plan was approved on August 13, 2001, that established evaluation points in the western entries of the F and G Panel bleeder. A methodology to evaluate the effectiveness of those evaluation points was also established. However, the mine operator was not conducting examinations at the approved points but, instead, had relocated the evaluation points without prior approval from MSHA. The points were relocated due to deteriorating roof conditions.

A supplement to the approved plan was approved on September 17, 2001. It established measurement point locations for the H Panel bleeder system after the F and G Panels were sealed. The plan did not include an approved supplement reflecting the use of Shaft 5-9.

### **Mine Ventilation**

The mine was ventilated with an exhausting system. Mine ventilation information is shown on the mine map in [Appendix S](#). Airflow entered the mine through four intake shafts and exited through two return shafts. The approximate reported airflow quantities that entered the mine through the intake shafts were as follows: 406,469 cfm through Production Shaft 5-2; 209,687 cfm through Service Shaft 5-3; 775,026 cfm through Intake Shaft 5-8; and 678,056 cfm through Shaft 5-9. Fan Shaft 5-1 and Fan Shaft 5-7 were return air shafts. Fan Shaft 5-1 was equipped with a TLT Babcock, Inc. fan, Type GAF 37.5/18-1, that operated at 4.6 inches of water gauge and exhausted a reported 210,369 cfm. Fan Shaft 5-7 was equipped with two TLT Babcock, Inc. fans, both Type GAF 37.5/18-1, installed in parallel. Prior to the accident, the operating pressures for Fan Shaft 5-7 Fan No. 1 and Fan No. 2 were 18.2 inches of water gauge and 18.8 inches of water gauge, respectively. The total Fan Shaft 5-7 return airflow was reportedly 1,859,004 cfm. Pressure recorder charts were obtained for each mine fan. [Appendix Z](#) shows the fan charts that were in use at the time of the accident for the Fan Shaft 5-7 Fan No. 1 and Fan No. 2.

### **Development Sections**

Both 4 and 6 Sections were ventilated with dual section return air courses. Air that ventilated the belt haulage entry in 4 Section was used to ventilate the faces. Record books indicated the air

quantities in the left and right return splits of 4 Section on the shift prior to the accident were 69,970 cfm and 72,565 cfm, respectively. Record books indicated the air quantities in the left and right return splits of 6 Section on the shift prior to the accident were 79,380 cfm and 82,140 cfm, respectively.

### Longwall Section

The H Panel longwall section had retreated approximately 100 feet. Record books for the longwall section on the shift prior to the accident indicated the air quantities measured on the face near the headgate, midface, and near the tailgate were 121,950 cfm, 93,600 cfm and 68,880 cfm, respectively. Air that ventilated the belt haulage entries was used to ventilate the face.

The H Panel was the last of three panels to be mined in the active longwall district. The longwall gob was ventilated with a wrap-around bleeder system. A spontaneous combustion plan was in effect. An extensive horizontal and vertical methane degasification program was utilized to assist the ventilation system. At the time of the accident, the mine operator was in the process of sealing the F and G Panels from H Panel and the rest of the mine. Of the twenty-five seals that were proposed, fourteen were completed and five others were under construction.

### Methane Ignitions and Fires

Methane ignitions and fires were not an unfamiliar occurrence at No. 5 Mine. During the one-year period prior to the accident, five methane ignitions had been investigated by MSHA. Three of the ignitions occurred in 4 Section, one occurred in 6 Section, and one occurred in G Panel longwall section. Each ignition resulted in a flame that required action to extinguish.

An ignition occurred in 4 Section on November 2, 2000. The continuous mining machine ignited methane while cutting rock in the mine floor. The resulting flame lasted for approximately three minutes and was extinguished with one 20-pound fire extinguisher and water. Another ignition occurred in G Panel longwall section on May 17, 2001. During preventive maintenance cutting (burning) operations, hot material ignited methane emanating from a crack in the mine floor. The resulting flame lasted for less than one minute and was extinguished with water. A second ignition occurred in 4 Section on August 30, 2001. The continuous mining machine ignited methane while cutting rock on the mine floor. The resulting flame lasted for approximately 25 minutes and was extinguished with ten 10-pound fire extinguishers, rock dust and a foam-generating machine. The third ignition within that year occurred in 4 Section on September 4, 2001. The continuous mining machine ignited methane while it was cutting rock near the mine floor. The machine was not maintained in a permissible condition. An opening existed in the entrance gland for the motor's power cable, exposing energized leads. The resulting flame lasted for approximately four minutes and was extinguished with ten 20-pound fire extinguishers and water. A 104(a) citation was issued for failure to maintain the continuous mining machine in permissible condition. An ignition in 6 Section occurred on September 19, 2001. During the installation of a roof bolt, methane was ignited when heat and/or sparks were generated, as the roof bolt contacted the roof bearing plate. The resulting flame lasted for approximately ten minutes and was extinguished with five 20-pound fire extinguishers, rock dust and water.

## **Methane Liberation**

The total methane exhausted daily from the mine through the exhaust fans varied due to mining cycles. Vacuum bottle samples and air quantity measurements taken by MSHA on July 12, 2001, and August 9, 2001, revealed the total methane liberation from the mine exhaust fans was approximately 17.2 million cubic feet per day (mcf/d). Additional methane was removed through the horizontal and vertical degasification systems.

Coal production affected methane liberation in 4 Section and 6 Section. The average methane liberation rate for 4 Section was approximately 1.4 mcf/d for the time period from September 2 through September 23, 2001. The average methane liberation rate for 6 Section was approximately 1.1 mcf/d for the time period from September 4 through September 23, 2001.

Barometric pressure changes were affected by regular daily atmospheric patterns (diurnal). The diurnal changes caused the barometric pressure to be higher before noon and lower in the afternoon hours. The accident occurred during the afternoon portion of the cycle. The barometric pressure was decreasing prior to the time of the first explosion and began rising prior to the second explosion. The rates of change were not unusual for the area. The variations in barometric pressure were determined not to have been a factor in the accident.

## **Ventilation Survey and Computer Simulations**

Information pertaining to the mine ventilation system was obtained during the investigation from various sources. These sources included mine records, fan charts, mine rescue team maps, underground investigation findings, and interviews and discussions with the operator and MSHA personnel. In addition, a mine ventilation pressure and air quantity survey was conducted from January 15-23, 2002. The information was used to create a computer simulation model of the mine ventilation system, as it existed prior to the events that occurred on September 23. [Appendix V](#) shows the portion of the model that depicts the likely ventilation scenario in 4 Section.

Computer simulations were developed to evaluate possible conditions in the mine immediately after the roof fall occurred in the No. 2 Entry in 4 Section, and after the first and second explosions. Changes to the model were also based on information gathered during the investigation. Portions of the simulation results are contained in Appendices [W](#), [X](#), and [Y](#).

The mine ventilation system was simulated reflecting conditions after the roof fall occurred. The results indicated the damage to the stopping behind the scoop battery charging station created a short circuit for some of the airflow ventilating the No. 1 and No. 2 Entry faces. The short circuit caused the airflow passing through the scoop battery charging station from the intake in the No. 2 Entry to the return in the No. 1 Entry to increase. Airflow in the section continued in its proper direction. Methane released from the roof fall and diluted by the airflow passing through the scoop battery charging station resulted in explosive methane-air mixtures that extended from the damaged battery into the No. 1 Entry. The airflow in the No. 1 Entry was probably sufficient to



dilute the methane-air mixture entering from the crosscut to below the explosive range within a short distance outby the crosscut. [Appendix W](#) depicts a ventilation scenario in 4 Section similar to what likely existed after the roof fall and before the first explosion.

A simulation of the mine ventilation system after the first explosion reflected the damage to various ventilation controls, including stoppings and overcasts in 4 Section, 6 Section and 4 East. The damage resulted in diminished airflow and altered airflow patterns in 4 Section. The simulation showed airflow reversed in the No. 2 Entry from the roof fall to the crosscuts outby the end of the track. It is likely methane liberated from the roof fall accumulated and an explosive methane-air mixture developed from the roof fall to outby the end of the track. [Appendix X](#) depicts a ventilation scenario in 4 Section similar to what likely existed after the first explosion.

Another simulation of the mine ventilation system indicated damage to various ventilation controls caused by the second explosion further affected airflow in the mine. The damage resulted in significantly altered airflow patterns inby the 3 East turn, as well as short circuits of airflow outby. [Appendix Y](#) depicts a ventilation scenario in the area of the mine inby the 3 East turn similar to what likely existed after the second explosion.

### **Cleanup and Rockdusting Procedures**

An Underground Mine Cleanup Plan had been established and was posted on the mine bulletin board. The plan described the program for regular cleanup and removal of accumulations of loose coal, coal dust, float coal dust, and other combustibles. The plan also identified the training and instruction required for the continuous mining machine operators relative to the cleaning of the mine floor.

The Mine Ventilation Plan described the dust control practices to be implemented and maintained at belt conveyor transfer points, loading points, underground crushers, underground dumps, belt and track haulage systems, face areas, shuttle car roadways, roof bolter dust boxes, and any other problem area. The dust control measures included water sprays, enclosures, rock dust applications, work practices, and the use of trickle rockdusters in the ventilation split where coal was being produced while the continuous mining machine was cutting.

The company employed a rockdust crew on each shift, seven days per week. However, members of the rockdust crew were sometimes assigned other tasks. Equipment and personnel may have been diverted from rockdusting activities during the recent longwall move. Bulk rock dust was sent into the mine from the surface through a rock dust borehole. The rockdust crews utilized track-mounted tank dusters to transport the bulk rock dust from the borehole to the active underground workings. The capacities of the tank dusters were four and six tons. Rock dust was transferred from the tank dusters through 2¼-inch diameter flexible hose and 2-inch diameter steel pipe to direct the rock dust to the desired location. Rock dust was also applied in bulk form in the return entries of the development sections. Rock dust was transported to the working sections in 3000-pound bags. The bulk dust bags were carried to the desired location in the bucket of a battery-powered scoop where they were broken and the rock dust spread out on the mine floor. The return entries of the working sections were also rockdusted using trickle rockdust

machines. Trickle dusters were manually filled each operating shift with rock dust from 50-pound bags. Scoop-mounted rockdusting machines were used on each working section to apply rock dust in the working places and in the last open crosscuts.

Normal coal mining activities created airborne coal dust. Float coal dust was deposited on previously rockdusted surfaces. Float coal dust deposits decreased the incombustible content of the mine dust in the affected areas. Mine management relied upon examinations and inspections to identify areas of the mine where rockdusting was deficient. Although float coal dust conditions were sometimes identified during examinations, they were not always considered hazards. A method referred to as ‘sweeping’ was sometimes used to mix the float coal dust layer with the previously applied rock dust using a broom. If the previously applied rock dust was not sufficient to maintain the required incombustible content of the mine dust, sweeping would not be effective and additional rock dust applications would be needed.

The coal production schedule had recently been changed from two to three shifts per day. The increase in production time per day could have affected the rate of advance and rockdusting requirements. Rockdusting intake air courses, including belt entries, during production shifts needed to be coordinated with production activities on the sections ventilated by the airflow passing through the areas to be rockdusted. The 4 Section and 6 Section track entries, from the 4 Section switch to the end of the track, were identified as needing rockdusted during an inspection conducted by a safety committeeman on September 21. There was no documentation to indicate the condition had been addressed prior to the accident.

### **Mine Dust**

A mine dust survey was conducted to assist in determining the cause and origin of the explosions and to determine the incombustible content throughout the affected area. The incombustible content of the combined coal dust, rock dust, and other dust must be maintained to at least 65% in the intake air courses and at least 80% in the return air courses, in the absence of methane, to meet regulatory requirements. A total of 648 samples were collected during four different time periods as the underground portion of the investigation progressed. At the conclusion of each day’s sampling activities, the samples were packaged and transported to MSHA’s laboratory in Mount Hope, WV for analysis.

The types of samples collected included band samples, taken around the entire perimeter at each location, roof-rib samples, and roof-only samples. Of the 648 samples collected, 338 samples were collected outby 3 East and 89 of these samples did not meet the incombustible requirements.

A total of 310 samples were collected throughout 3 East, 4 East, 4 Section, 6 Section, and the connecting entries for Shaft 5-9. Of these samples, 305 were below an incombustible content of 65% in the intake air courses and an incombustible content of 80% in the return air courses. Of the 310 samples, 123 were band samples. Only band samples were considered to determine compliance with the regulations. The results revealed 121 (98.4%) of the samples did not meet the regulatory requirements for incombustible content of the combined coal dust, rock dust, and other dust. [Appendix R](#) shows the results of testing on mine dust samples.

Two activities conducted during the recovery process, but prior to the mine dust survey, could have affected the sample results. First, water was pumped into the mine through Shaft 5-9 to extinguish the fire in 6 Section and to isolate the suspected explosion area from the remaining mine workings. Most of the underground mine workings inby 2 East were inundated. Surface moisture is removed prior to testing. If inherent moisture increased as a result of flooding, the incombustible content of the samples would have been further increased. Only inherent moisture, not surface moisture, contributes to incombustible content of mine dust. The sample results were evaluated for areas in 4 Section that were not affected by the flooding. All of the 31 samples collected in this area were below the regulatory requirements for incombustible content.

Second, about 88.5 tons of rock dust had been dumped into the mine through Intake Shaft 5-8 during the recovery operation. Airborne rock dust would have been deposited on the surfaces of the mine entries in 2 East inby the intake shaft. The additional rock dust elevated the incombustible content of samples taken from the affected areas.

Sloughage is a result of coal breaking from the ribs and accumulating on the mine floor. Because of the characteristics of the coal, overburden, and the mining method, some sloughage was present throughout most of the mine. Flooding the area affected the coal ribs, causing increased amounts of sloughage. Sloughage would have little affect on the sample results. Virtually all of the sloughage material was too large to be included in mine dust samples because it would not pass through a No. 10 sieve.

Scouring of the solid portion of the roof, ribs, and floor does not occur during an explosion. As the flame of an explosion burns fuel, forces are developed. These forces travel in all directions away from the ignition source. For example, forces traveling outby in any entry split at each crosscut, with a resulting force traveling through each crosscut. Not only does the force travel outby in the entry and into each crosscut, it also impacts against the roof, ribs, and floor in a perpendicular direction. The forces impacting against the perimeter surfaces of the mine act to prevent large quantities of dust from becoming suspended during the explosion. During the initial thrust of an explosion, up to one-half inch of dust can be suspended before the explosion forces act to restrict any additional dust from suspending. Scouring of the solid portions of the roof, ribs, and floor would not occur during an explosion because of the impact of the perpendicular explosion forces against, rather than along, these surfaces. Therefore, scouring did not have an impact on the incombustible content of the mine dust.

There were nine mine dust surveys conducted by MSHA within the 12-month period prior to the accident. The surveys were conducted to quantify the incombustible content of the mine dust. Six of the nine surveys indicated noncompliance with the standards of 30 CFR 75.403. The last rock dust survey taken by MSHA in 4 Section was on September 20, 2001. Two samples were taken in each of the 4 entries, beginning at SS 13295 in the No. 2 Entry and ending at SS 13319 in the No. 2 Entry. The results of the survey were received after the accident occurred. Three of the eight samples analyzed were below the minimum level for incombustible content. The last mine dust survey taken in 6 Section was on June 15, 2001. The 6 Section was mining in the vicinity of Shaft 5-9 at the time of the survey. A total of 14 samples were collected, nine samples in the

intake entries and five in the return entries. Four of the 14 samples analyzed were below the minimum level for incombustible content.

Samples of rock dust were collected for analysis. The results of the analysis revealed all of the rock dust samples conformed to the requirements of 30 CFR 75.2. Each type of rock dust contained less than 0.5% combustible matter and the free and combined silica ranged from 1.01% to 1.51%. Each type was light colored and 100% passed through a sieve having 20 meshes per linear inch while between 79% and 84% passed through a sieve having 200 meshes per linear inch.

There were 99 violations of 30 CFR 75.400 issued during the 12-month period preceding the accident. At the time of the accident, 12 of those violations were not terminated according to MSHA records. However, company records and statements from those who were responsible for ensuring the conditions were abated indicated some corrective action had been taken in the twelve cited areas. The areas affected by the outstanding violations are shown in Table 4.

Table 4 – Outstanding Section 75.400 Violations

<b>Date Issued</b>	<b>Area Affected</b>	<b>Extent of Condition</b>	<b>Remarks</b>
09-04-01	No. 1 LW -- 'F' HG return	1200' of float coal dust	Swept 600' on 9-5-01; Applied 2 tanks of rock dust on 9-6-01.
09-14-01	Sub Main B Belt Conveyor	7000' of float coal dust	Two miners swept belt entry on 9-14-01; Applied 2 tanks of rock dust on 9-15-01; Applied 1 additional tank of rock dust on 9-16-01.
09-14-01	Sub Main A Belt Conveyor	925' of float coal dust; also, loose coal & coal dust from drive to header	Two miners swept belt entry on 9-14-01; Cleaned belt from header to track overcast on 9-15-01.
09-14-01	3 East Belt Conveyor	3000' of float coal dust; also, 7 x-cuts of loose coal & muck	Two miners cleaned drive area on 9-15-01; Two miners swept belt entry and cleaned along belt on 9-17-01; Dusted 3 East header to drive on 9-17-01; Dusted 3 East header on 9-18-01.
09-17-01	LW Escapeway	46 x-cuts of float coal dust	Dusted 3 x-cuts on 9-17-01; Swept prop entry and dusted 7 x-cuts on 9-18-01; Swept prop entry from 5 x-cut to new regulator on 9-19-01.
09-18-01	Future 3 East Belt Entry	1000' of float coal dust	Two tanks of rock dust applied from 2 East tailpiece to 3 East on 9-19-01.
09-18-01	2 East Belt Conveyor	2700' of float coal dust	Dusted 400' on 9-18-01; Dusted 400' on 9-19-01; Applied 3 tanks of rock dust on 9-19-01; Three miners cleaned/shoveled belt on 9-19-01; Dusted 100' on 9-20-01; Applied 1 tank of rock dust on 9-20-01.
09-19-01	No. 68 Diesel Locomotive	Diesel fuel and coal dust on locomotive	Removed from mine on 9-19-01.
09-20-01	4 East Belt Conveyor	300' of float coal dust	Applied 2 tanks of rock dust on 9-21-01; One miner swept belt on 9-21-01.
09-20-01	4 Section Left Return	1000' of float coal dust	Applied remaining dust from the 2 tanks that were used at 4 East Belt Drive area on 9-21-01.
09-20-01	2 East Belt Conveyor	300' of float coal dust	Three miners cleaned drive/take-up area on 9-20-01; Two miners swept belt entry on 9-20 & 21-01; Dusted from header to track overcast on 9-21-01; Dusted 300' on 9-22-01.
09-20-01	4 Section Belt Conveyor	30' of loose coal and muck	Miners assigned to clean area on 9-20-01; Applied rock dust on 9-21-01; Applied 2 additional tanks of rock dust on 9-22-01.

## **Examinations**

Mine examinations were conducted by various certified mine examiners pursuant to the requirements of Sections 75.360, 75.362, and 75.364. The certified examiners included both salaried and hourly employees. Section foremen normally conducted preshift and on-shift examinations during production shifts. Hourly personnel sometimes conducted preshift examinations on non-producing shifts. Both salaried and hourly employees conducted on-shift and preshift examinations along belt haulage entries.

Section 75.360 requires an examination by a certified person within 3 hours preceding the beginning of any 8-hour interval during which any person is scheduled to work or travel underground. The certified examiner is required to examine for hazardous conditions, test for methane and oxygen deficiency, and determine if air is moving in its proper direction at specific locations such as travelways, working sections, and seals along intake air courses. The mine operated three production shifts that began at 7:00 a.m., 3:00 p.m., and 11:00 p.m. Preshift examinations were performed based upon three 8-hour time periods associated with the start of these production shifts.

In addition to the mine examination records required by the regulations, the mine operator maintained a separate book in which conditions that required attention, but were not considered hazards, were recorded. For example, float coal dust accumulations were sometimes recorded in this separate book as a maintenance condition.

The section foremen who conducted the preshift and on-shift examinations of the 4 Section knew most of the requirements of Sections 75.360 and 75.362. However, a deficiency existed in that a notation of “excessive methane” was sometimes recorded rather than the actual detected level of methane. The persons interviewed stated methane concentrations greater than 1.0% were considered “excessive methane” and recorded as such in the record books. Section 75.360 requires the results of methane tests be recorded as the percentage of methane.

Adequate preshift/on-shift examinations were not conducted in 4 Section for the afternoon shift on September 22, as well as the midnight, day and afternoon shifts on September 23. A hazardous condition, consisting of inadequate rock dust, was not identified by the examiners. Coal was last produced on the day shift on September 22. All of the 31 mine dust band samples collected during the investigation in the inby area of 4 Section did not meet the regulatory requirements. The average incombustible content was less than 40%, indicating that the incombustible content was significantly below the regulatory requirements. The condition was obvious, widespread, and present in the areas traveled by the examiners as they conducted the respective preshift/on-shift examinations.

The preshift examination for 4 Section for the day shift on Sunday, September 23, included an examination of the power center and the scoop battery charging station. It did not include an examination of the working places where personnel had been scheduled to work. The day shift section foreman made an examination of the working places prior to miners entering the working

places. However, because the work was scheduled prior to the beginning of the preshift examination, these areas were required to be included in the preshift examination.

There were no records to indicate preshift examinations were conducted in a number of areas where personnel were scheduled to work on the afternoon shift of September 23. These included the 2 East Sump area, the F Panel Headgate area, and the H Panel Tailgate area. C. Key, Boyd and Banks were scheduled to work in the 2 East Sump area. Connor, Bailey and Willingham were scheduled to work in the F Panel Headgate area. Riggs, Smith and Stewart were scheduled to work in the H Panel Tailgate.

Section 75.364 requires a weekly examination of worked-out areas, the bleeder system, an examination for hazardous conditions at specific locations that include in at least one entry of the intake and return air courses in their entirety, at each seal along a return or bleeder entry, and measurement of air volume and tests for methane at specific locations. Hourly employees conducted the majority of the weekly examinations. Interviews with mine personnel and a review of the records of weekly examinations conducted during the week prior to the explosion indicated deficiencies including the following: no air quantities were measured to determine the volume of air entering the main intakes at Intake Shaft 5-8 or at Shaft 5-9; no air quantities were measured leaving the main returns at Fan Shaft 5-1 or at Fan Shaft 5-7; no air quantities were measured to determine the volume of air in the intake splits of the belt conveyor and track entries, and; there were several records of hazardous conditions observed during the weekly examination but no corresponding records of the corrective action taken to abate the conditions.

Four hourly miners, safety committeemen, performed independent safety inspections in underground areas of the mine when not traveling with MSHA inspectors. Three of the four employees were not certified to conduct examinations. Through interviews, it was determined management did not conduct a preshift or a supplemental examination prior to these employees entering unexamined areas.

### **Electrical**

Three-phase electric power was purchased from Alabama Power Company and transmitted to the mine through overhead high-voltage lines at 110,000 volts alternating current (ac). A 10,000-kilovolt-ampere (kva) transformer, located in a surface substation near the mine Service Shaft, reduced the voltage to 4160 volts ac for surface distribution. Two 3500 kva and one 3000 kva transformers increased the voltage from 4160 volts ac to 7200 volts ac for underground distribution. Circuit protection was provided by individual high-voltage rated circuit breakers, visible disconnects, and lightning arresters located in the surface substation. Each of the three high-voltage circuit breakers contained relays designed to provide overcurrent, short circuit, grounded phase, and under-voltage protection. A ground check circuit was provided to monitor continuously the grounding circuit.

The three independent 7200-volt power circuits entered the underground area of the mine via 4/0 high-voltage cables down the Service Shaft. Three portable power centers with visible disconnects and vacuum circuit breakers were located at the bottom of the Service Shaft to

provide protection to the high-voltage circuits before they distributed power to other areas of the mine. Nine additional vacuum breaker power centers were used at branch circuits to isolate and protect these high-voltage circuits. All 7200-volt connections between power centers were made with 4/0 MP-GC, 8 kilovolt (kv) rated high-voltage cable. Approximately 30 transformer power centers reduced the voltage for utilization by the conveyor belt system, methane degasification operations, pumps, Production Shaft bottom, the 4 Section and 6 Section.

A separate 5000 kva 110,000/7200 volts ac transformer located in a surface substation, approximately 2.5 miles from the Service Shaft, provided power to the longwall section. The 7200-volt power circuit entered the mine by means of a 4/0 high-voltage cable down a borehole. This circuit was provided protection by a high-voltage circuit breaker, visible disconnects, and lightning arresters located in the surface substation and a vacuum breaker power center located at the bottom of the borehole near the mouth of H Panel. Both circuit breakers contained a ground check circuit and relays to provide overcurrent, short circuit, grounded phase and under-voltage protection for the longwall section high-voltage circuits.

### **Potential Ignition Sources**

The electrical circuits, cables and equipment located in 4 Section were tested and examined for evidence they provided the ignition source for either explosion. The diesel equipment was also examined. Evidence and testimony indicated some circuits and equipment were not energized during either the first or second explosion, however, they were tested and investigated to corroborate this evidence. The 4 East circuits and equipment were examined to determine how they provided power inby to 4 Section. The points of origin of the first and second explosions are discussed in subsequent sections of this report. The potential ignition sources in the areas of the points of origin are discussed in this section. The results of tests and examinations of the other circuits and equipment in 4 East and 4 Section are contained in [Appendix AA](#). The locations of electrical equipment, diesel equipment and electrical circuits in areas of 3 East, 4 East and 4 Section are shown on the mine map in [Appendix T](#). Appendices [BB](#) and [CC](#) contain the 4 Section and 4 East high-voltage electrical schematic diagram and the 4 Section block light electrical circuit diagram, respectively.

Testimony indicated electrical tests were conducted on the high-voltage system during the day shift on September 23. These tests caused intermittent loss of power to portions of the high-voltage system, including 4 Section. High-voltage electrical power was restored to the 4 Section power center after the tests were completed during the latter part of the day shift. The three-phase circuit breakers for the low and medium-voltage output circuits of the power center had opened from the loss of power. They were not closed after the high-voltage power was restored because only non-production work and maintenance activities were being conducted. During the afternoon shift, only the continuous mining machine circuit was energized, to move the machine from the last open crosscut of the No. 1 Entry to the face of the No. 1 Entry.

After the first explosion, T. Key met Nail and Mobley just inby the 4 Section vacuum breaker power center. T. Key gave instructions to de-energize the high-voltage circuit for 4 Section at this location. The investigation determined this was done and the visible disconnects for the 4



Section vacuum breaker were opened. Opening the visible disconnects at the 4 Section vacuum breaker power center would have opened the high-voltage circuit at the mouth of 4 Section and de-energized the 4 Section belt transformer, 4 Section power center, and all high-voltage cable in 4 Section.

Potential Ignition Sources in the Area of the First Explosion

Scoop Tractor Battery Assembly, Douglas Battery Manufacturing Company, Certification No. 2250-3, Serial No. 202341135-L and Serial No. 20234135-R. The battery assembly was located under a roof fall in the crosscut between the No. 1 and the No. 2 Entries near SS 13333. The battery assembly was connected to the charger prior to the roof fall. The assembly consisted of two separate compartments that contained 64-volt batteries rated at 765 ampere-hours. Each battery contained 32 individual cells of two volts, each connected in series by parallel lead straps. The 400 ampere, 600-volt, Model 1251 PG-RG battery plugs attached to the left and right battery receptacles were made by J&R Manufacturing Company and issued MSHA Certification Number 4088-0. A permissibility examination was completed for the battery assembly. No significant conflicts in design or construction with the approval documents were noted.

Some electrolyte was removed from three of the battery cells to perform specific gravity determinations. A subsequent analysis of the electrolyte showed a very low specific gravity reading in the range of about 1.100. A fully charged battery has a specific gravity of 1.285 and water has a specific gravity of 1.000. Also, open circuit voltage measurements of the cells in both the left and right side battery assemblies confirmed the nearly complete discharged state of the batteries. The open circuit voltage on the left side assembly measured 10.94 volts. The right side measured 7.17 volts between cell No. 4 and cell No. 32. Cells No. 1 through No. 3 on the right side assembly were physically damaged, resulting in voltage measurements which were inconclusive.

The right side battery assembly, cell No. 5, was shorted with a lead intercell connection bridging the positive and negative post of the cell. This would reduce the overall nominal output voltage of the battery assembly from 64 volts to 62 volts.

Although both right and left side battery assemblies sustained physical damage due to the roof fall, the right side assembly was the most severely damaged. The left side batteries did not show any areas that may have produced an ignition source. An examination of the right side battery assembly identified four areas of special interest. [Appendix DD](#) contains photographs of the damaged battery assembly as well as other No. 5 Mine photographs.

- The two lead strap intercell connections between battery cell No. 2 and cell No. 3 were crushed between the cover and internal steel frame of the right side battery compartment. This action caused both the 60-volt section and the 4-volt section of the battery cells to come in electrical contact with the frame of the assembly. Laboratory testing confirmed the portions of the lead strapping that had contacted the steel frame melted as a result of high current flow due to a short circuit. The report concluded "... the contact between the steel case and the intercell connectors momentarily produced considerable heat for the period of

contact.” Current flow in this area was determined to be sufficient to raise the temperature of a portion of the steel frame structure in this area to approximately 1,200 to 1,400°F, or more, for a period of time.

- The positive 1/0 AWG battery cable (24 gauge wire strands) was damaged by the pressure of the battery cover against the internal steel frame of the right side battery compartment. This caused the positive conductor (wire) of this portion of the battery cable to come in electrical contact with the frame of the assembly. Under these conditions, a 4-volt potential was available to contribute short circuit current between the cable and frame. Laboratory examination of the cable’s damaged area with a low power microscope revealed melting had occurred, affecting about five strands, due to the short circuit condition. The localized melting of the wire strands would have required temperatures exceeding 1,900°F, based on the melting point of copper.
- The negative battery terminal on cell No. 32 of the right side battery assembly was in electrical contact with the outer part of the battery tray frame near a ventilation opening located in this area. This would have completed the short circuit current path involving the intercell connections between cell No. 2 and cell No. 3. Under these conditions, a 58-volt potential was available to contribute short circuit current between the intercell connections and frame for the period of electrical contact with the intercell connectors. Laboratory testing confirmed electrical activity in this area was sufficient to raise the temperature of the steel frame structure of the battery assembly to approximately 1,700°F for a period of time at the point of contact with the negative battery terminal.
- Both the positive and negative side battery cables showed signs of overheating where the cables connected to the terminals on the battery plug. The 1/0 welding type cables had insulation that was cracked and brittle near the terminal connections. Some of the wire strands had melted at this location. The roof fall could have shorted these two cables together between the battery and battery charger. This event would have caused a short circuit condition that produced high current flow from the batteries through the terminals to the short. However, this situation is unlikely because the batteries were already shorted internally to the frame and no voltage was available at the cable leads to produce current. Also, a portion of the external battery charging cables were recovered from the roof fall and no signs of overheating from excess current were evident on the insulation or in the wire strands of these cables. The heat damage from the cable connections at the battery receptacle terminals probably existed before the accident because of inefficient connections.

As a result of this work, it was concluded the damage to the right side battery assembly was sufficient to cause incendive arcing and sparking. Also, thermal ignition sources were considered likely to have existed for a period of time within the battery cell area as a result of the roof fall. The ignition temperature of methane is about 1,000°F. Temperatures exceeding this value were shown, through laboratory testing and analysis, to exist for a period of time within the battery assembly. Based on this information, the most likely sources for ignition were in the areas of contact between the steel frame of the battery tray with the negative battery terminal and with the intercell connectors. Also, electrical activity in the region of the battery assembly, where the

damage to the positive battery cable occurred, was considered sufficient to be regarded as a potential ignition source. The right side battery could have provided the ignition source for the first explosion.

Douglas Manufacturing Company Battery Charger and Input Cable. A Model or Serial Number could not be read from the nameplate on the charger. The battery charger for the 120-volt scoop tractor batteries was located in the crosscut between the No. 1 and No. 2 Entries near SS 13333. The battery charger was partially covered by a roof fall just before the first explosion. The 600-volt charger and its trailing cable were protected by a 180-ampere circuit breaker on the section power center. The circuit breaker handle was in the center-tripped position. The No. 6 trailing cable's receptacle for the charger was plugged into the section power center. The trailing cable was supported from the mine roof. The cable extended from the power center to its location under the roof fall. Tests with an ohmmeter between phase and ground and between phases of the conductors of the cable outby the fall did not indicate any grounded or shorted conductors under the fall.

The charger output circuits and fuses were checked with an ohmmeter. There were no fault connections to ground (charger frame) or no open fuses identified. There were no indications from the physical examination that provided evidence the charger was energized at the time of the roof fall. This examination corroborated the testimony that the battery charger was not energized at the time of the roof fall.

The input cable for the battery charger was an Anaconda brand, No. 6 gauge, 3 conductor, type G-GC, with 2000-volt insulation. Approximately 435 feet of the cable was examined visually and with a meter to determine damaged areas and signs of electrical activity. There were no indications the cable was energized before the first explosion.

The battery charger and its input cable did not provide the ignition source for the first explosion. This conclusion was based on the examination of the charger and cable and the fact neither the charger, nor the cable, was energized at the time of the roof fall.

High-voltage Cable, Essex 4/0, 8 kv Shielded. The high-voltage cable for 4 Section provided 7200 volts to the vacuum breaker power center, belt transformer, and the section power center. The cable exited the 4 Section belt transformer feed-through and was supported from the roof along the left side of the No. 2 Entry to the 4 Section power center. The cable was covered by the roof fall in the No. 2 Entry near the battery charging station for about 90 feet. From the end of the track to the power center, the cable only received minor physical damage from the first and second explosions. However, heat damage to the outer jacket existed where the cable was supported next to the roof between the roof fall and the power center. The cable was severely damaged in several locations at the mouth of 4 Section.

The high-voltage cable could not be visually examined where it lay under the roof fall. Resistive tests were conducted with a permissible volt-ohmmeter between each phase and between each phase and ground of the conductors in the cable on each side of the roof fall. The results did not indicate any internal damage to the cable.

However, if damage had occurred, the design of the cable with a grounded shield surrounding each conductor would have produced a grounded phase or short circuit condition. The 4 Section vacuum breaker at the mouth of 4 Section provided grounded phase and short circuit protection for this circuit. The protective devices for these vacuum breakers would have acted in less than a second after the damage occurred and de-energized the cable. The first explosion did not occur until approximately three minutes after the roof fall.

It was unlikely the high-voltage cable provided the ignition source for the first explosion. This conclusion was based on the measurements on the cable, the construction of the cable (shielded conductors), the electrical protection for the circuit, and the timing of the roof fall in relation to the first explosion.

Telephone Cable, General Cable. The telephone cable was supported from the roof in the center of No. 2 Entry from the mouth of 4 Section to the telephone in by the power center. The PVC coated cable was constructed with 18.5 gauge copper covered steel conductor wires. The telephone cable was under the roof fall through the SS 13333 intersection. The cable was damaged from the roof fall and forces and heat from the explosions. There was approximately 20,000 feet of telephone cable from the surface to the telephone on 4 Section.

The telephone system for the underground area of the mine was of a permissible design. The surface components of the system as well as the telephone and cable in 4 Section were examined and tested. Voltage measurements made of the telephone system indicated 19.53 volts peak to peak could exist on the telephone system during paging. Paging to 4 Section could only be accomplished from the surface telephone system or a telephone located at the bottom of the Service Shaft. The impedance of the cable at the mine was measured and calculated from the surface to 4 Section. Spark tests were conducted of the shorted cable in an explosive methane-air mixture and no ignitions of the methane occurred.

Further testing was done on the Gai-Tronics Model 491-204, MSHA Approval 9B-43-4, telephone recovered in 4 Section. The telephone operated properly and spark ignition testing was conducted on the output of the telephone during paging and no ignitions occurred with the explosive methane-air mixture.

Surge protective devices protected the telephone lines entering the mine. The protectors were rated 18.7 volts minimum and 26 volts maximum. These devices fail when their ratings are exceeded. None of these devices had failed which indicated external voltages were not introduced to the telephone system.

The telephone system and its cable did not provide the ignition source for the first explosion. This conclusion was based on the permissible design of the telephone system that prevented sufficient energy to be available to ignite methane anywhere in the system and test results that confirmed this fact.

### Potential Ignition Sources in the Area of the Second Explosion

Block Light Slave Unit and Cable. The block light slave unit was located in the No. 2 Entry just outby the end of the track. The block light master unit was located at the mouth of 4 Section. The block light cable was supported from the roof in the No. 2 Entry from the master to the slave unit. The block light system used 120-volt control power for the signal and to activate the lights, as shown in [Appendix CC](#).

The block lights and cable formed a mine-wide system for controlling traffic that used light signals at track switches. Each end of the section of track on which traffic was to be controlled had a set of lights. This section was referred to as a block. When a vehicle operator came to a block he observed the lights. If no light was activated, then no other vehicle was occupying that block. A miner then shined his cap lamp on a photocell that activated the system and transferred control of that block. The light on one end of the block turned green and the other end turned red. If the other end of the block was not reached in a specified amount of time, the lights on both ends turned amber. When the photocell on the other end of the block was activated, the lights on each end turned off and the block was cleared.

The block light system used two boxes with three lights and a photocell mounted in each. One box was referred to as the master unit and the other as the slave unit. A programmable logic controller (PLC), a small computer, controlled the lights, depending on the signals it received from either photocell.

A block light slave unit was mounted in the No. 2 Entry of 4 Section between SS 13303 and SS 13295, which is just outby the end of the track. The block light master unit was not found. Testimony indicated the light was at the mouth of 4 Section in the No. 2 Entry near SS 12825. A 16 gauge, 3 conductor, type SO cable provided 120-volt power to the block light master unit. The unit and cable was protected by a 20-ampere circuit breaker on the 4 East belt transformer. The circuit breaker was in the closed position.

The block light cable (16 gauge, 12 conductor, Type SDT) was supported along the right side of the No. 2 Entry. The cable connected the master unit to the slave unit. Usually slack cable was rolled up and stored behind the slave unit to be unwound as the section, track, and ultimately the slave unit were advanced. The cable was damaged in several locations near the end of the track. The cable had been pulled from its hangers after the first explosion and positioned near the mine track. Most of the damage to the cable resulted from becoming entangled, and run over, by a diesel locomotive that had made a round trip from the end of the track to the return overcast at the mouth of the section after the first explosion. Some of the cable was entangled on the rear of the locomotive near the end of the track. Approximately 530 feet of the block light cable was taken from 4 Section for examination and testing.

Testimony and physical evidence indicated high-voltage power to 4 Section was de-energized at the 4 Section vacuum breaker after the first explosion. The investigation determined that the visible disconnects were open on the 4 Section vacuum breaker power center and the Emergency stop switch (E-stop) on the power center was in a trip position. Both conditions would have

removed high-voltage power to 4 Section. However, the E-stop would have de-energized power outby to the 4 East vacuum breaker and also removed power to the block light system (See Appendices T and BB). The position of the E-stop was inconclusive in determining the status of the block light system because forces from the second explosion could have tripped the E-stop as well as actions by a miner.

Further investigation was conducted to determine if the block light system for 4 Section was energized at the time of the second explosion. The visible disconnects were gang operated knife blade switches located in the power center that opens or closes the high-voltage circuit. A lever-type handle located on the side of the power center controlled them. Opening the visible disconnects on the 4 Section vacuum breaker would have removed the high-voltage power inby to the 4 Section belt transformer, the high-voltage cable from the vacuum breaker to the 4 Section power center and the 4 Section power center. The E-Stop was a push button switch located on the input end of the power center that caused the incoming high-voltage circuit to be de-energized at the nearest outby vacuum breaker providing protection for the circuit. The E-Stop on the 4 Section vacuum breaker would have opened the 4 East vacuum breaker. This was significant because the 4 East vacuum breaker controlled power to the 4 East belt transformer that provided power to the block light system for 4 East and 4 Section. If only the visible disconnects in the 4 Section vacuum breaker power center had been opened prior to the second explosion, power would have remained on the 4 East belt transformer and the block lights. If the E-Stop was also pushed, the 4 East vacuum breaker would have opened and de-energized the 4 East belt transformer. This action would have de-energized the block light systems for 4 East and 4 Section.

Evidence indicated forces from the second explosion that impacted the 4 Section vacuum breaker power center may have caused its E-Stop to close. The 4 Section belt transformer power center was located in the same crosscut as the 4 Section vacuum breaker. Both power centers were positioned in the same direction with the E-Stop on the No. 2 Entry side. Both power centers were similarly impacted by the force of the second explosion from the No. 3 Entry side. The E-Stop for the belt transformer power center was also in the trip position. It is unlikely that Nail or Mobley walked through the stopping separating the power centers to push the E-Stop on the belt transformer. They would have known that opening the visible disconnects on the vacuum breaker would have already de-energized the belt transformer.

Additional evidence indicated the block light systems in 4 East and 4 Section were energized until the second explosion. A 5-ampere fuse located in the hard plastic box enclosure of the slave unit for the 4 East block light system was opened from electrical energy. An independent testing laboratory concluded the fuse failed electrically, "... probably due to an electrical short circuit." A hole was knocked into the enclosure causing the mounting structure of the bottom light to be forced inside the compartment. The fuse blew from an electrical short caused when a portion of the light contacted another portion of the electrical circuit with a different potential. This fuse only protected internal circuits inside the block light housing. No other short circuits existed in the block light housing from the internal wiring. Therefore, it was determined the short circuit occurred when the indicator light holder and block light housing were damaged by external forces. The hole in the box that dislodged the light was most likely caused from debris propelled

by forces of the second explosion. This slave unit was located at the mouth of 4 East near SS 12712, which is approximately 1700 feet from the first explosion and not in direct line of the forces. Debris would not have been propelled to this location from the first explosion. The second explosion had much greater force and damaged structures at this location. The fuse could have failed electrically only if the block light was energized when it was damaged. Only the second explosion generated forces sufficient to propel debris to its location and damage the block light.

The 4 East vacuum breaker that controlled power to the 4 East belt transformer and the block light system was most likely closed at the time of the second explosion. The overcurrent, short circuit and ground fault protective relay flag indicators were in an activated position on the 4 East vacuum breaker. This is indicative of severe damage to the high-voltage circuit in by this location with the circuit energized. Severe damage to the high-voltage circuit only occurred after the second explosion. If the E-Stop had been pushed on the 4 Section vacuum breaker after the first explosion, the high-voltage circuit would have been de-energized in by the 4 East vacuum breaker. It is possible the 4 East relay flag indicators were jarred in the activated position by the forces of the second explosion. However, the flag indicators on the 6 Section vacuum breaker power center were not in an activated position and its power center was subjected to greater forces than the 4 East vacuum breaker power center.

The block light cable was examined to determine if any melting or arcing occurred on the cable. There were no signs observed. Tests were conducted using strands of wire from the block light cable to determine the magnitude of current necessary to cause visible signs of burn marks or strand melting. A current level of about 10 amperes was necessary to cause visible marks using a low power microscope. These 10-ampere marks were still not sufficient to be seen by the naked eye. A one-ampere fuse limited the output signal from the PLC of the block light. A 5-ampere fuse limited the signal from the photocell. This one ampere and five ampere limitation would have prevented visible arcing or melting on the damaged cable but would still have produced enough energy to ignite methane.

The block light circuit that existed in 4 Section was simulated in a laboratory using block lights from the mine and cable impedances equivalent to those present before the accident. The circuit was connected to a 120-volt source as existed at the mine. An arc was created simulating a faulted cable in an explosive methane-air mixture and in a spark testing chamber. As little as .08 amperes of electrical current ignited the methane. This indicated that a short circuit in the wires supplying power to either the photocells or indicator lights provided sufficient energy to ignite an explosive concentration of methane. Because the indicator lights operate on .08 amperes, the arc energy created by making or breaking the wire connection supplying power to one of these lights was also sufficient to ignite an explosive concentration of methane.

When a cap lamp is directed toward a block light on either end of the system, a 120-volt signal is transmitted through the cable to the other end depending on the status of the system. If the system is not in use, a light shown on either end will transmit the 120-volt signal to the opposite end via the block light cable. At the time of the second explosion, miners had just arrived at the mouth of 4 Section near the block light master unit and other miners had just arrived at the end of

the track near the block light slave unit. A light striking either the master or slave photocell would have produced a 120-volt signal on the damaged block light cable and this could have produced an incendive arc in the cable. Also, the miners arriving at the end of the track could have contacted or moved the cable, causing the damaged conductors to be moved, producing an arc.

Because the block light cable had been run over and entangled by the diesel locomotive after the first explosion, the cable was damaged at several locations that exposed power conductors. This damage occurred near the end of the track. The cable was also pulled and damaged where it entered the slave unit enclosure. It was not determined if the cable was pulled completely out of the slave unit before the second explosion. The damaged cable was located in an area where the miners, who had just arrived near the end of the track, could have contacted the cable. Miners were also located behind the locomotive in a position to possibly move the cable off the track in preparation to move the locomotive. Any movement of the cable by miners or a cap lamp striking the photo cell on the slave unit could have caused an incendive arc created by the shorting of the damaged conductors.

The block light system most likely provided the ignition source for the second explosion. This conclusion was based on the examination and testing of the block light system on 4 East and 4 Section to determine if it was energized, the arrival of the miners near the master and slave unit just before the second explosion, the location of the damaged cable and slave unit near the end of the track in the No. 2 Entry, and the lab simulation that demonstrated the system had ample energy to ignite an explosive methane-air mixture.

Eimco Diesel Locomotive, Model 150 D, Serial No. 150-885565. The 15-ton nonpermissible rail locomotive was located near the end of the mine track in the No. 2 Entry at SS 13303. This location was six crosscuts outby the last open crosscut of 4 Section. The locomotive was powered by an air-cooled Deutz Model F6L413FW, 139 horsepower, V-6 cylinder engine with a three-speed automatic transmission. The locomotive used two 12-volt batteries connected in series to produce a 24-volt direct current electrical system. No victims were located in the operator's compartment.

The disconnects for the batteries were in the closed position. The master power switch that controlled all electrical functions, including starting the engine, and energizing the glow plugs and lights, was in the off position. The ignition switch was in the off position. The light switch for the inby (engine) end of the machine was in the on position. The light switch for the outby (operator) end of the machine was in the on position. The lever in the operator's compartment, which controls the direction of travel for the machine, was in the forward position for inby travel. The gear selector was in the down position, which placed the transmission in third, or high gear. The spring-applied pneumatically-released wheel park brake was in the set position. The operator may have set the brake or the brake may have set when an air hose ruptured during the explosion and caused a loss of pressure.

The accident did moderate damage to the locomotive. The two outby headlights were blown out. The intake air filter housing was blown from its connection. The covering for the engine on the



inby side was damaged. The fire sensor wire for the Ansul automatic fire suppression system had melted.

The diesel locomotive was running at the time of the first explosion. This was verified through testimony. The diesel locomotive was not running at the time of the second explosion. This was verified by the location of the victims, position of the controls, and the fact dust had not been drawn into the valve ports with the filter housing missing.

Tests were conducted on the locomotive seat to determine if the seat was occupied at the time of the second explosion. There was no evidence the seat cushion or the seat back cover material was shielded from the heat of an explosion by someone sitting in the seat at the time of the event.

A detailed examination of the 24-volt electrical system was conducted to determine if any arcing from the wiring or components could have provided an ignition source for the explosion. No indications of arcing, heating or insulation damage were observed. Since the master power switch was in the off position, there was no power to any of the electrical components except the primary of the master switch and engine starter. There were no unintentional loads from shorts on the machine. There were no intentional loads from the position of the controls. Therefore, no current was flowing in the electrical system of the locomotive. This was verified with a direct current (dc) ammeter that showed no current flow existed from the batteries. The batteries on the locomotive were tested on December 12 by cranking the engine. Both tests indicated the batteries had not discharged since September 23. If any current drain had been present during this 80-day period, the batteries would have been discharged.

For the following reasons, it was unlikely the locomotive provided the ignition source for the second explosion:

- an examination of the electrical system revealed no heating, arcing or insulation damage to the wiring or electrical components;
- the master electrical switch was in an off position, preventing any electrical components or control circuitry from being energized; and
- the machine was not running as verified by the location of the victims, position of the controls, and the fact dust was not drawn into the valve ports with the filter housing missing.

However, the diesel locomotive could not be ruled out as a possible ignition source, because the 24-volt electrical system had sufficient energy to ignite methane. Energized circuits existed under the battery lids and to the primary side of the master switch and engine starter. Although no signs of arcing were observed, incendive arcing can occur without producing visible evidence.

Jeffrey Diesel Ramcar, Model 4110, Serial No. 40189. The permissible rubber-tired Ramcar was located in the right crosscut of No. 2 Entry at the fueling location near SS 13303. The Ramcar was powered by a water-cooled MWM Model D916-6, 94-horsepower, in-line six-cylinder

engine with an automatic transmission. Because the Ramcar was of a permissible design, the machine had no batteries.

The transmission was in neutral with the emergency park brake set. The water scrubber, an engine safety component that provides for exhaust gas cooling and flame arresting protection, contained a sufficient amount of water to function properly. The engine coolant in the radiator was adequate. The fuel tank contained fuel.

The machine received moderate damage from the explosion. Several engine compartment covers were blown from the machine exposing the engine. The machine was not being operated at the time of the accident. The examination of the machine revealed it was in permissible condition.

The diesel Ramcar did not provide the ignition source for the second explosion. This conclusion was based on the permissibility examination and state of operation of the machine.

Jeffrey Diesel Ramcar, Model 4110, Serial No. 38740. The permissible rubber-tired Ramcar was located in the No. 2 Entry between SS 13303 and SS 13312. The Ramcar was powered by a water-cooled MWM Model D916-6, 94-horsepower, in-line six-cylinder engine with an automatic transmission. Because the Ramcar was of a permissible design, the machine had no batteries.

The transmission was in neutral with the emergency park brake set. The water scrubber, an engine safety component that provides for exhaust gas cooling and flame arresting protection, contained a sufficient amount of water to function properly. The engine coolant in the radiator was adequate. The fuel tank contained fuel.

The machine received moderate damage from the explosion. Several engine compartment covers were blown from the machine exposing the engine. The machine was not being operated at the time of the accident. The permissibility examination revealed no discrepancies that could cause a methane ignition.

The diesel Ramcar did not provide the ignition source for the second explosion. This conclusion was based on the permissibility examination and state of operation of the machine.

Koehler Cap Lamps and Batteries. Two complete cap lamp assemblies, six headpieces, and five batteries were recovered from 4 Section. These assemblies and components were thoroughly inspected for visible signs that they were the source for an ignition. There was no evidence that any of these components provided an ignition source.

The Koehler batteries consisted of two lead acid cells of 2 volts, each connected in series to produce 4 volts dc. All battery voltages were measured and the leads shorted to determine the battery's internal resistance. They were filled with electrolyte, charged and shorted in an explosive methane-air mixture. None of the batteries ignited methane.

The number of assemblies found was less than the number of victims. The assemblies recovered could not be correlated to the identities of the users. T. Key and McLe lost their cap lamps and batteries during the first explosion. In an attempt to determine the hazards associated with cap lamp assemblies similar to those recovered, several tests were performed. These tests were the headpiece ignition containment test, the headpiece lens impact test, the temperature testing of metallic battery cover, flash current testing, battery short-circuit test, and the cord conductor strand ignition test.

The results of these tests have not revealed any evidence to conclude the cap lamps and batteries were ignition sources. Although all cap lamps and batteries present at the time of the explosion were not recovered and examined, the mine uses the same type cap lamp and batteries. From the results of the assemblies tested, it is unlikely the other lamps and batteries would have provided an ignition source for the second explosion.

High-Voltage Cable, Essex 4/0, 8 kv Shielded Located in the No. 2 Entry Near the End of the Track. The high-voltage cable was laying on the ground near the left side of the entry at this location. The cable was examined and no physical damage was detected. The 4 Section vacuum breaker that protected this cable was examined. The visible disconnects for the vacuum breaker were in the open position. This action was done before the second explosion. Opening of the visible disconnects would have removed power to the high-voltage cable.

The high-voltage cable was not an ignition source for the second explosion. This conclusion was based on the examination of the cable at this location and the fact that the cable was de-energized before the second explosion.

Telephone Cable Located Near the End of the Track in the No. 2 Entry in 4 Section. The telephone cable was examined at this location. Little physical damage to the cable was observed. Tests conducted of the telephone system and cable determined that insufficient energy was available to ignite an explosive methane-air mixture. The telephone cable did not provide the ignition source for the second explosion. This conclusion was based on the examination of the cable at this location, the permissible design of the telephone system, and testing of the telephone system and cable.

### **Origin, Flame and Forces**

At the beginning of the afternoon shift on September 23, ventilation of 4 Section was normal. Roof conditions were deteriorating in the SS 13333 intersection. A roof fall eventually occurred in the intersection.

A battery charger and a scoop battery were located in the crosscut between the No. 1 and the No. 2 Entries, adjacent to the SS 13333 intersection. Although the scoop battery was covered by the roof fall, the charger was only partially covered. Neither the charger nor the battery experienced total physical destruction, although a significant amount of internal and external damage to the battery resulted from the roof fall. The charger and charger cable experienced little damage. The roof fall also covered a section of telephone cable and a high-voltage electrical cable. The fall of

material from the roof extended vertically into several layers of overlying strata, including the Mary Lee coal seam. Methane from the overlying strata entered the mine.

The roof fall did not ignite methane or produce any flame. The force generated by the roof fall resulted from the rapid displacement of air. The overpressure produced did not achieve the magnitude necessary to compromise ventilation controls in 4 Section, such as stoppings and regulators. The stopping between the No. 1 and the No. 2 Entries near SS 13333 was partially crushed out prior to, and as a direct result of, the roof fall.

### First Explosion

The first explosion occurred at the location of the roof fall. This determination was based on an analysis of post-explosion evidence, on statements made by victims who were underground at the time of the explosion, and on the results of an underground investigation.

Explosions can only develop when proper quantities of oxygen, fuel, and heat are available, and when the fuel is suspended within a confined volume. The normal atmospheric concentration of oxygen occurred throughout the active mine workings and was about 20.9%. Methane only requires 12% or more oxygen to burn or ignite. Similarly, coal dust requires a minimum of 13% oxygen to burn or ignite. Explosive quantities of coal dust were not suspended or ignited during the roof fall or the first explosion. As methane entered the confined mine workings from the overlying strata, it remained suspended in the mine atmosphere. The oxygen, suspension, and confinement requirements for the first explosion were satisfied immediately after the roof fall. After the roof fall, heat/energy for the explosion was available. Within three minutes, the fuel entered the explosive range at the location of the ignition source.

### Ignition Sources

The heat requirements to initiate an explosion are satisfied by either temperature or energy. Potential ignition sources are those sources that exceed the minimum temperature or energy requirements for the fuel that ignited. Potential ignition sources are located where the ignition occurred. The first explosion was fueled by methane. Methane can be ignited by temperatures as low as 1000° F or by the energy of 0.3 millijoule. Resistors begin to glow at 1000° F. The static charge that can accumulate on a person contains about 50 times the energy of 0.3 millijoule.

The potential ignition sources for the first explosion are limited to those that were located at or near the roof fall. These include the battery charger and cable, the scoop battery, the telephone cable, and the high-voltage electrical cable. The scoop battery was the ignition source for the first explosion. The battery was damaged by the roof fall causing incendive arcing and sufficient heat to ignite methane. The high-voltage cable was considered an unlikely source because of the design of the cable, the design of the high-voltage circuit, and the results of tests made on the cable. The battery charger and cable were eliminated because they were not energized. The telephone cable was eliminated because it did not have sufficient energy to ignite methane.

### *Fuel and Resulting Flame*

Only methane fueled the first explosion. Methane concentrations within the explosive range can ignite and can contribute to the development of flame. Methane concentrations above or below the explosive range can not contribute to a methane explosion. The first explosion produced limited flame propagation and a low magnitude of forces.

Methane released from the roof fall began to immediately mix with the ventilating air. This mixing action resulted in dilution of the methane body to varying degrees, with a portion of the methane entering the explosive range of 5% to 15%. The explosive body of methane extended from the scoop battery through the crosscut and into the No. 1 Entry. Airflow in the No. 1 Entry began to dilute the methane coming from the crosscut. The volume and velocity of airflow in the No. 1 Entry was not sufficient to immediately mix all of the methane, but allowed a small volume of methane in the explosive range to exist along the right rib for a short distance outby the crosscut.

Flame typically affects about five times the volume of mine opening that initially contained the explosive methane-air mixture. Therefore, flame length can be used to determine the amount of methane consumed in a methane explosion. The flame of the first explosion did not travel a significant distance in any direction. After ignition, the flame traveled through the crosscut toward and into the No. 1 Entry. The flame traveled a short distance outby in the No. 1 Entry because the explosive methane body occurred there.

Three miners were in the No. 2 Entry approximately 60 feet outby the roof fall. Although the mine atmosphere at their location became heated, they were not exposed to flame. The flame length that occurred during the first explosion is estimated to have affected about 40 linear feet of mine opening from the roof fall into and outby in the No. 1 Entry. As a part of the initial developing fireball, a short flame also traveled in all other directions.

Samples of the mine dust were analyzed for incombustible content and the presence of coke. A summary of the mine dust survey is included in the subsequent discussion pertaining to the second explosion. When sufficient quantities of incombustible contents are present in the mine dust, coal dust can be prevented from participating in a propagating explosion. The minimum incombustible content that can prevent an explosion of any coal dust is 65%. The post-explosion incombustible content of mine dust in the No. 1 Entry of 4 Section within 200 feet outby the roof fall was found to be 49.1%. Although insufficient, this quantity of incombustible content may have cooled the limited explosion flame enough to prevent coal dust from igniting in the short distance traveled by the methane explosion. A coal dust cloud can ignite at temperatures as low as 834° F.

The quantity of methane that became involved in the first explosion was estimated to be about 100 cubic feet. This 100 cubic feet of methane was diluted to about an average of 12%, which affected 835 cubic feet of mine opening. The flame speed was on the order of 300 feet per second. The explosion flame was extinguished as the available fuel was consumed.

### *Forces and Resulting Damage*

Although the resulting flame propagated from the area of the roof fall primarily toward the No. 1 Entry, it also traveled in all other directions to a limited extent. As flame developed and traveled through the available explosive methane, explosion forces were generated from the heating and expansion of the mine atmosphere. These forces affected all areas of 4 Section to varying degrees. Research has shown that explosion forces can change in magnitude throughout the explosion zone, depending on the quantity of fuel being consumed at each location and the obstructions encountered. This action can cause destruction of some ventilation controls while allowing other controls to survive the explosion forces. The flame and force damage caused by the first explosion is shown in [Appendix P](#).

The main thrust of primary explosion forces from the first explosion was initially outby in the No. 1 Entry and reached a magnitude of about 4 psi. Forces that extend into the crosscuts are about 50% of the force that continues outby. The explosion developed the 2 psi pressure necessary to blow the stopping between SS 13326 and SS 13332 toward the No. 2 Entry. Since methane was quickly consumed, explosion pressures began to deteriorate as they continued outby. The next three stoppings outby were not exposed to destructive pressures. However, as the remaining forces impacted the regulator in the No. 1 Entry, the magnitude of those forces increased due to the obstruction. The regulator was damaged and blown outby. The increased pressure allowed for the partial damage of the three stoppings between the No. 1 and No. 2 Entries inby the regulator. The loss of these stoppings allowed pressures to continue outby in the No. 2 Entry and to propagate into the No. 3 Entry.

The forces traveling outby remained at approximately 2 psi as they impacted the overcasts at the mouth of 4 Section. The overcasts were damaged as a result. Also, the forces traveling outby in the No. 1 Entry damaged the stopping in 4 East that was in line with the No. 1 Entry of 4 Section, just outby SS 12833. Although forces continued to deteriorate, other stoppings in 4 East and 6 Section were also damaged.

### *Second Explosion*

Explosive methane-air mixtures had migrated outby in the No. 2 Entry from the roof fall to just outby the end of the 4 Section track. Immediately prior to the second explosion, sufficient quantities of coal dust to support explosion propagation were not in suspension. It is impossible to breathe in an atmosphere containing explosive quantities of suspended coal dust. Methane was the fuel that initially ignited at the onset of the second explosion. A fireball developed when arcing, mostly likely from the 4 Section block light system, ignited methane and a flame began propagating inby. A shock wave traveled ahead of the ensuing flame front, causing coal dust to be placed in suspension. Coal dust became involved in the explosion.

As the flame front continued inby, the suspended cloud of coal dust was encountered prior to reaching the last open crosscut. The minimum ignition temperature of the coal dust was exceeded and the coal dust ignited. The methane concentrations in the face areas of the No. 1 and the No. 2 Entries were greater than the explosive limit. The flame of a coal dust explosion will not

propagate into a dead end. As a dead end is approached, air and flame speeds decrease. When speeds are reduced below approximately 150 feet per second, the explosion flame would extinguish. The faces of the No. 1 Entry and No. 2 Entry were not exposed to the flame of the explosion. Coal dust was fueling the explosion as the flame and forces turned into the last open crosscut and continued toward the No. 3 and the No. 4 Entries. Pressures of approximately 2 psi entered the last open crosscut. The flame speed traveling through the last open crosscut remained near 300 feet per second.

It is likely that explosive quantities of methane existed in the faces of the No. 3 and No. 4 Entries. Methane fueled the explosion as the flame propagated inby the last open crosscut in these two entries. Methane in concentrations below the explosive range existed outby the last open crosscut in the No. 4 Entry. Although methane concentrations in this entry were below the explosive range, any methane would allow coal dust to more easily become involved in the explosion. As the explosion flame approached the No. 3 and the No. 4 Entries, the flame speed reduced as the propagating flame front was forced to change directions. This was the location where additional coal dust and methane from the face areas began contributing to the explosion and pressures increased. The explosion flame propagated outby in the No. 3 Entry and No. 4 Entry with a flame speed approaching 1,000 feet per second and a magnitude of near 12 psi. The shock wave continued to place coal dust into suspension, feeding the propagating flame for the extended distances shown on the mine map in [Appendix Q](#).

The flame of the second explosion propagated throughout all of 4 Section, 6 Section, 4 East, the connecting entries for Shaft 5-9, and most of 3 East. Pressure relief occurred as the flame entered 3 East, causing flame speeds to drop below the levels necessary for a continuing coal dust explosion and the flame extinguished.

The extent of flame and the magnitude of the explosion forces were significantly greater during the second explosion, indicating a larger volume of involved fuel. The flame and force damage caused by the second explosion is shown in [Appendix Q](#).

### *Ignition Sources*

Inby the end of the track, evidence of primary forces indicated that they were heading inby toward the faces. Evidence indicated primary explosion forces just outby the end of the track were heading outby. The zone from which primary forces propagate in all directions is referred to as the “transition zone.” The potential ignition sources are all located within the transition zone. The transition zone for the second explosion was the general area surrounding the end of the track.

Potential ignition sources within this area included the diesel locomotive, two diesel Ramcars, cap lamps and batteries, the block light unit and cable, the high-voltage cable, and the telephone system. The block light system was the most likely ignition source for the second explosion. The system was energized at the time of the explosion and the block light cable had damaged exposed conductors in the explosion origin zone. Tests indicated the system had sufficient energy to ignite methane. The diesel locomotive at the end of the track was considered an unlikely source

because an examination of the vehicle's electrical system indicated no insulation failures or signs of arcing, because the operational state of the controls prevented most electrical components from being energized and the vehicle was not running. The two diesel Ramcars were eliminated as a source because of their permissible design and the state of operation of the machines. The cap lamp and batteries were eliminated because of their permissible design and tests indicated the batteries would not ignite methane if they were shorted at the output leads. The high-voltage cable was eliminated as a source because the cable was de-energized at the time of the second explosion. The telephone cable was eliminated because it did not have sufficient energy to ignite methane.

### *Fuel and Resulting Flame*

The extent of flame for the second explosion is based on observations and test results of mine dust samples taken during the underground investigation. During the mine dust survey, a total of 648 dust samples were taken. The samples were primarily band samples from around the entire perimeter of the mine entry at each location. All samples were analyzed for the presence of coke and incombustible content. Results of the Alcohol Coke Test and the Incombustible Analysis are shown on the mine map in [Appendix R](#).

The Alcohol Coke Test identifies whether samples have no coke, a trace, small, large, or an extra-large quantity of coke. Coking occurs during partial combustion of coal. The temperature required for coking to commence varies with the coal but is on the order of 700° F. The flame temperatures during an explosion are approximately 1800° F. Coal exposed to explosion flame does not always coke. Research has shown that coking does not occur when high flame speeds are achieved because the coal is only exposed to these elevated temperatures for several milliseconds. Coking also does not occur beyond the extent of flame. The explosion flame produces large and extra-large quantities of coke.

A significant amount of coke was formed throughout 4 Section, 6 Section, 4 East, the connecting entries for Shaft 5-9, and 3 East during the second explosion. Research has shown that coke can only form in mine dust that has an incombustible content of less than 50% prior to an explosion.

The flame of the second explosion did not propagate into any areas outby 3 East. The flame of the second explosion propagated throughout most of 3 East, throughout the entirety of 4 East and 6 Section, the area surrounding Shaft 5-9, and the entirety of 4 Section. Table 5 shows the results of the alcohol coke test.



Table 5 – Alcohol Coke Test Results

<b>Location</b>	<b>Number of Samples</b>	<b>No Coke</b>	<b>Trace Coke</b>	<b>Small Coke</b>	<b>Large Coke</b>	<b>Extra Large Coke</b>
Outby 3 East	338	295	29	14	0	0
3 East	109	5	9	27	10	58
4 East and 6 Section	101	0	3	12	19	67
Shaft 5-9 Area	10	1	4	2	1	2
4 Section	90	1	18	21	23	27

The intentional flooding of a portion of the mine after the second explosion did not have an effect on the results of the Alcohol Coke Test. During the second explosion, a significant quantity of coke was formed throughout a large area of the affected mine workings. The results of testing on these mine dust samples clearly indicate the presence of large and extra-large quantities of coke and, therefore, reveal areas affected by the explosion flame.

Results of the mine dust survey accurately reveal the incombustible content of mine dusts after an explosion. The incombustible content of the mine dust prior to the explosion is critical. A coal dust explosion will be extinguished as it propagates into an area containing 65% incombustible in the intake entries or 80% incombustible in the return entries. As the flame of a dust explosion travels through an area, the combustible portion of the dust becomes involved and allows for the continued propagation of the flame. Explosion forces do cause dust dispersion and transport during an explosion. However, oscillating pressure waves allow for dusts and other debris to be moved in both directions until ambient conditions finally return.

In research explosions where the incombustible content is uniform throughout the test zone, post-explosion incombustible contents are higher than the original incombustible contents. In the tests conducted, when the original incombustible content of all dust was 65%, the average incombustible content in the dust collected from the rib-roof surfaces after the research explosion was 77%. The incombustible content in the dust collected from the floor after the research explosion was 69%.

In addition, the Proximate Analysis of coal determines the ash, moisture, volatile content, and fixed carbon portions of the coal. The incombustible contents of mine dusts consist of the ash and moisture components of the dust. Flooding of a portion of the mine prior to sampling did not change the ash, volatile content, or fixed carbon components of the samples. Surface moisture is removed prior to testing. If inherent moisture increased as a result of flooding, the incombustible content of the samples would have been further increased. Only inherent moisture, not surface moisture, contributes to incombustible content of mine dust.

#### *Forces and Resulting Damage*

The initial methane ignition caused a fireball to develop in the No. 2 Entry of 4 Section, near the end of the track. Because explosive quantities of methane existed in the inby direction, the flame

propagated inby in the No. 2 Entry. The forces developed during the early stage of the explosion were on the order of 2 psi. Although the flame was initially fueled by methane, it became a coal dust explosion prior to entering the last open crosscut of 4 Section. The full magnitude of explosion pressures was not realized until the explosion reached the No. 3 and No. 4 Entries in the last open crosscut. The redirection of the propagating forces caused large amounts of coal dust to become suspended. This is evidenced by the extra-large quantities of coke that formed in this area. When the suspended coal dust and explosive methane became involved, greater flame speeds and explosion pressures were developed.

The flame and forces of the explosion propagated outby in both the No. 3 and the No. 4 Entries generating about 12 psi. The flame of the explosion did not travel back through the last open crosscut toward the No. 1 Entry because there would not have been sufficient oxygen to support combustion. However, secondary forces did travel back through the last open crosscut. These secondary forces were of a significantly greater magnitude than the primary forces that initially passed through the crosscut. The primary forces heading toward the No. 3 and No. 4 Entries generated about 2 psi. The secondary forces heading back toward the No. 1 and the No. 2 Entries generated approximately 10 psi. As these forces turned outby in the No. 1 and No. 2 Entries, they began to deteriorate.

As the explosion flame exited 4 Section, it continued to propagate throughout 4 East and 6 Section. Since additional fuel in the form of coal dust continued to be suspended and ignited, the flame and forces remained relatively constant. From the mouth of 4 Section, the flame simultaneously continued toward both 3 East and the connecting entries for Shaft 5-9. The explosion approached Shaft 5-9 from both 6 Section and 3 East. The separate flames could not overlap each other due to the lack of oxygen in areas traversed by a propagating flame front. Shaft 5-9 provided a direction for flame to travel and allowed venting of explosion forces.

### **ROOT CAUSE ANALYSIS**

A root cause analysis was conducted. Causal factors were identified that could have averted the accident entirely or mitigated the severity of the accident in terms of loss of life.

During development, the SS 13333 intersection was permanently supported with 72-inch fully grouted resin bolts and metal straps. The roof and rib conditions in this area were not considered unusual. Changes were not noticed in the conditions until the day shift on Friday, September 21. A small crack in the roof was observed, a noise was heard, and water was dripping from some roof bolt holes. The section coordinator directed the section foreman to have cable bolts installed through the intersection. About sixteen, 10-foot long cable bolts were installed during day shift on Friday. While drilling, methane, water, broken coal and broken shale were encountered above the anchorage zone of the primary roof supports (72-inch fully grouted resin bolts). Competent roof was not encountered in the anchorage zone of many of the cable bolt holes.

During drilling of the cable bolt holes, the potential seriousness of the condition was not accurately determined by those working in 4 Section and, thus, was not fully communicated to the section coordinator. This lack of communication was influenced by two factors. According to

testimony, roof falls had not previously occurred in areas where cable bolts had been installed. Miners generally believed the area was adequately supported.

A change in the conditions in the SS 13333 intersection became evident during day shift on Sunday, September 23. The conditions progressively deteriorated throughout the shift. Sloughage of the ribs increased, water flow increased and noises associated with ground movement increased. Roof movement occurred as evidenced by the developing cracks. Convergence was evident on the posts and stopping in the crosscut adjacent to the intersection. At the end of day shift, the section foreman called out a preshift examination report identifying further deterioration of the mine roof. Plans were made to install cribs on the afternoon shift. The section foreman on the afternoon shift Sunday, September 23, found the condition had further deteriorated requiring the installation of cribs over a larger area. Continued convergence on the stopping in the crosscut adjacent to the intersection resulted in irreparable damage. Arrangements to replace the stopping were made. The roof continued to deteriorate during the installation of the cribs and it eventually fell.

Causal Factor: During drilling of the cable bolt holes, the potential seriousness of the condition was not accurately determined by those working in 4 Section and, thus, was not fully communicated to the section coordinator.

Based on his independent assessment of the roof and rib conditions at the intersection, the section coordinator had directed that cable bolts be installed through the intersection at SS 13333. About sixteen, 10-foot long cable bolts were installed during day shift on Friday. While drilling, methane, water, broken coal and broken shale were encountered above the anchorage zone of the primary roof supports (72-inch fully grouted resin bolts). Competent roof was not encountered in the anchorage zone of many of the cable bolt holes.

The section coordinator was not informed about the conditions encountered. If the section coordinator had been aware of the potential seriousness of the condition, it is possible the roof fall could have been prevented.

Corrective Action: Passive cable bolt theory and installation procedures should be reviewed with supervisors and roof bolters to assure that they understand the principles of resin anchorage and the roof conditions in which they are effective. Abnormal, unusual, or unexpected roof conditions should be elevated to the attention of upper management immediately.

Causal Factor: A timely mine evacuation was not initiated by mine management.

Although there were several opportunities for mine management to order a mine-wide evacuation, a timely evacuation of the workforce did not occur. The section foreman and the CO Room supervisor had sufficient information to warrant a mine-wide evacuation. Other underground management personnel initially had little or erroneous information upon which to base their decisions and actions. However, sufficient information was available to indicate all underground miners needed to be evacuated from the mine except those necessary to address the situation.

The established practice at the mine was to respond to ignitions and fires to extinguish them as quickly as possible. It was determined through interviews and a review of the mine records that all miners were not participating in fire drills every 90 days, as required by 30 CFR 1101-23(c). In addition to these facts, it was known that a fellow miner in 4 Section was injured and in need of assistance. Nevertheless, mine management is responsible for safely directing the workforce and for evacuating miners not needed to respond to an emergency.

Had a mine-wide evacuation been promptly initiated, leaving rescue attempts to a small group or to mine rescue teams, the severity of the accident and loss of life could have been reduced or prevented.

*Corrective Action:* Mine practices and procedures should be reviewed to ensure that responsibilities and responses to mine emergencies are clearly delineated and all underground personnel should be familiar with the procedures.

*Causal Factor:* The block light system in 4 Section remained energized.

There were two reasons why the block light system in 4 Section was not de-energized. First, the section foreman leaving 4 Section after the initial explosion, had directed electricians to de-energize the power to the section. As discussed in the electrical section of this report, the visible disconnect at the mouth of the section was opened but power remained on the block system leading into 4 Section. The electricians may not have realized or considered the block light system was powered by another power source. Second, the section foreman attempted to contact the surface to direct all underground power circuits be de-energized. It is believed this communication was not completed due to a malfunctioning telephone at the 3 East turn. It is unlikely the first explosion damaged the telephone.

If the block light system in 4 Section had been de-energized, then the second explosion most likely would have been avoided.

*Corrective Action:* Underground electrical configurations should be reviewed to assure that their design or complexity would not confuse foremen and electricians. Unusual configurations should be made known to all persons working in the area. All underground mine telephones should be maintained in operational condition.

*Causal Factor:* Rock dust applications were inadequate.

The second explosion propagated due to the involvement of coal dust. The coking analysis results show the incombustible content was inadequate over an extensive area. The mine had procedures for cleaning and rockdusting areas as section moves were completed. However, there was no procedure to regularly or routinely re-apply rock dust in outby areas. Mine management relied on examiners and inspectors to identify outby areas in need of rock dust. There were 99 violations of 30 CFR 75.400 issued during the 12-month period preceding the accident. The result of this reactive approach was that coal dust and float coal dust accumulated for various periods of time without being rockdusted. In addition, areas identified by examiners as needing

rock dust were often considered and recorded as maintenance items rather than treated as critical safety issues.

Prior to the accident, two events occurred which impacted rockdusting in 4 Section. During the recent longwall move, equipment and personnel normally assigned to rockdusting may have been diverted to assist in the move. Also, the mine had started producing coal in 4 Section on all three shifts where previously there had been one non-producing shift during which rockdusting could be performed. Except between shifts, there was virtually no opportunity to rockdust intake and belt entries during the three production shifts. Miners assigned to rockdusting were sometimes unable to apply rock dust in adequate amounts. High air velocities in belt entries along with dust generating belt transfer points contributed to mine coal dust and float coal dust accumulations. While it may have a place in a mine's overall system, the mine practice of sweeping did not increase the incombustible content of dust. The clean-up and rockdusting practices were ineffective. Preshift/on-shift examinations did not identify inadequate rock dust as a hazardous condition. In 4 Section, all 31 band samples in the inby area of the section did not meet the regulatory requirements.

If the 4 Section had been adequately rockdusted, coal dust would not have contributed to the second explosion and the severity of the accident. The number of fatalities would have been reduced.

*Corrective Action:* Mine examiners should identify and record accumulations of coal dust and float coal dust as hazardous conditions and make the appropriate corrections. Mine management should develop and follow procedures, timetables, and schedules to proactively re-apply rock dust in outby areas. The identification of areas where float coal dust and coal dust are found by examiners and inspectors should be used as a check to assure the adequacy of the procedure for re-application of rock dust. Adequate amounts of rock dust must be applied. Dust suppression techniques used in face areas, along belt lines, and at transfer points should be evaluated for possible improvements. Management should be aware that sweeping is not an acceptable substitute for rockdusting to increase incombustible content.

## CONCLUSION

On September 23, 2001, two separate explosions occurred at approximately 5:20 p.m. and 6:15 p.m. in 4 Section of the No. 5 Mine, resulting in fatal injuries to thirteen miners.

The roof conditions deteriorated at the SS 13333 intersection. Although supplemental roof support material was installed, it was not sufficient to control the mine roof. A roof fall eventually occurred at this intersection, releasing methane and damaging a scoop battery. An explosion occurred within minutes after the roof fall when methane was ignited by arcing of the damaged battery. The explosion damaged critical ventilation controls and disrupted the airflow. The explosion resulted in injuries to 4 miners. One of the injured miners may have sustained fatal injuries.

Mine management was aware an explosion had occurred that resulted in damage to critical ventilation controls. They did not implement the mine evacuation plan. Methane accumulated in 4 Section, including in the face areas and in the No. 2 Entry. Miners re-entered 4 Section to rescue the remaining miner without any handheld gas detectors. While the power circuit to 4 Section was de-energized, the track haulage block light system that extended into 4 Section remained energized.

The second explosion occurred when methane in the No. 2 Entry was most likely ignited by the block light system. The failure to recognize inadequately rockdusted areas and maintain the incombustible content of the mine dust at or above regulatory standards resulted in coal dust becoming the primary fuel for the continued propagation of the explosion. This explosion resulted in at least 12 fatalities and widespread destruction of ventilation controls throughout the mine.

The accident resulted from a failure to accurately determine the seriousness of the deteriorating roof conditions at the SS 13333 intersection. Contributing to the severity of the accident was the failure to maintain the incombustible content of rockdusted surfaces in accordance with the regulation and failure to identify the conditions during preshift/on-shift examinations. Also contributing to the severity of the accident was the failure of mine management to initiate a mine-wide evacuation and the failure to de-energize all electrical circuits entering 4 Section after the first explosion.

Approved:

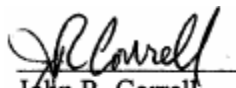
  
John R. Correll  
Deputy Assistant Secretary  
For Mine Safety and Health

**ENFORCEMENT ACTIONS** - *Contributing Violations (in addition to a 103(k) Order)*

Citation, 104(d)(1), 75.403, S&S, High Negligence. On September 23, 2001, two separate explosions occurred in 4 Section, resulting in fatal injuries to thirteen miners. During the investigation, a total of 123 mine dust samples were collected throughout 3 East, 4 East, 4 Section, 6 Section and the connecting entries for Shaft 5-9. These band samples were subjected to an Incombustible Analysis. The results revealed that 121 (98.4%) of the sample results did not meet the regulatory requirements for incombustible content of the combined coal dust, rock dust and other dust of at least 65% in the intake air courses and at least 80% in the return air courses. None of the 31 band samples taken in the inby area of 4 Section met the regulatory requirements. This area of 4 Section was not flooded during recovery operations and was the location where both explosions originated. This was also the area where coal dust became the primary fuel for the second explosion. The condition contributed to the severity and extent of the second explosion that resulted in fatal injuries.

Order, 104(d)(1), 75.1101-23(a), S&S, High Negligence. On September 23, 2001, two separate explosions occurred in 4 Section, resulting in fatal injuries to thirteen miners. A proper evacuation procedure was not followed after the first explosion on 4 Section. Miners were not evacuated from the mine after an explosion damaged critical ventilation controls. These conditions were known by, and communicated to, management personnel, including the CO Room Supervisor. The section foreman believed there was a possibility of a second explosion and did not effectively communicate this information to other miners.

Miners from other areas of the mine responded to the emergency on 4 Section believing either an ignition or a fire had occurred. These miners were unaware an explosion had occurred and a second explosion was possible. Miners underground were not alerted to the problem through the mine-wide telephone paging system. Also, management directed 7 additional miners to join the 13 miners already in 4 Section.

Order, 104(d)(1), 75.1101-23(c), S&S, High Negligence. On September 23, 2001, two separate explosions occurred in 4 Section, resulting in fatal injuries to thirteen miners. The accident investigation revealed the operator failed to conduct fire and emergency drills at intervals of not more than 90 days. Interviews of underground miners and a review of mine records indicate that no such drills had been conducted since March, 2001. The lack of training and simulation relative to proper evacuation procedures to be followed in the event of an emergency affected the miners' response to the emergency situation of September 23.

Order, 104(d)(1), 75.360(b)(3), S&S, High Negligence. On September 23, 2001, two separate explosions occurred in 4 Section, resulting in fatal injuries to thirteen miners. The accident investigation revealed that an adequate preshift examination was not conducted in 4 Section where persons were scheduled to perform maintenance work during the oncoming afternoon shift on September 22, 2001. A hazardous condition consisting of inadequate rock dust existed, but was not identified by the examiner. The condition was obvious, widespread, and in the areas traveled by the examiner. During the investigation, mine dust samples were collected throughout 4 Section. These band samples were subjected to an Incombustible Analysis. The results

revealed that approximately 97% of the sample results did not meet the regulatory requirements for incombustible content of the combined coal dust, rock dust, and other dust. None of the 31 band samples taken in the inby area of 4 Section met the regulatory requirements. The average incombustible content was less than 40%, indicating a condition significantly below the regulatory requirements that should have been recognized by a prudent mine examiner. This area of 4 Section was not flooded during recovery operations and was the location where both explosions originated. This was also the area where coal dust became the primary fuel for the second explosion. The condition contributed to the severity and extent of the second explosion that resulted in fatal injuries. The Order will not be terminated until hazard recognition training is provided for certified mine examiners at the No. 5 Mine.

Order, 104(d)(1), 75.362(a)(1), S&S, High Negligence. On September 23, 2001, two separate explosions occurred in 4 Section, resulting in fatal injuries to thirteen miners. The accident investigation revealed that an adequate on-shift examination was not conducted in 4 Section where two mechanics were assigned to work during the afternoon shift on September 22, 2001. A hazardous condition consisting of inadequate rock dust existed, but was not identified by the examiner. The condition was obvious, widespread, and in the areas traveled by the examiner. During the investigation, mine dust samples were collected throughout 4 Section. These band samples were subjected to an Incombustible Analysis. The results revealed that approximately 97% of the sample results did not meet the regulatory requirements for incombustible content of the combined coal dust, rock dust, and other dust. None of the 31 band samples taken in the inby area of 4 Section met the regulatory requirements. The average incombustible content was less than 40%, indicating a condition significantly below the regulatory requirements that should have been recognized by a prudent mine examiner. This area of 4 Section was not flooded during recovery operations and was the location where both explosions originated. This was also the area where coal dust became the primary fuel for the second explosion. The condition contributed to the severity and extent of the second explosion that resulted in fatal injuries. The Order will not be terminated until hazard recognition training is provided for certified mine examiners at the No. 5 Mine.

Order, 104(d)(1), 75.360(b)(3), S&S, High Negligence. On September 23, 2001, two separate explosions occurred in 4 Section, resulting in fatal injuries to thirteen miners. The accident investigation revealed that an adequate preshift examination was not conducted in 4 Section where persons were scheduled to perform maintenance work and install roof bolts during the oncoming day shift on September 23, 2001. The examination was incomplete in that an examination of the working places was not conducted where miners were scheduled to roof bolt the unsupported face areas. The main mine fan had been off during the previous shift, creating the potential for methane accumulations in the long crosscuts between No. 2 and No. 3 Entries as well as in the face areas. The examiner was not made aware of these circumstances and was instructed by mine management to limit the examination to the electrical installations only. In addition, a hazardous condition consisting of inadequate rock dust existed, but was not identified by the examiner. The condition was obvious, widespread, and in the areas traveled by the examiner. During the investigation, mine dust samples were collected throughout 4 Section. These band samples were subjected to an Incombustible Analysis. The results revealed that approximately 97% of the sample results did not meet the regulatory requirements for



incombustible content of the combined coal dust, rock dust, and other dust. None of the 31 band samples taken in the inby area of 4 Section met the regulatory requirements. The average incombustible content was less than 40%, indicating a condition significantly below the regulatory requirements that should have been recognized by a prudent mine examiner. This area of 4 Section was not flooded during recovery operations and was the location where both explosions originated. This was also the area where coal dust became the primary fuel for the second explosion. The condition contributed to the severity and extent of the second explosion that resulted in fatal injuries. The Order will not be terminated until hazard recognition training is provided for certified mine examiners at the No. 5 Mine.

Order, 104(d)(1), 75.360(b)(3), S&S, High Negligence. On September 23, 2001, two separate explosions occurred in 4 Section, resulting in fatal injuries to thirteen miners. The accident investigation revealed that an adequate preshift examination was not conducted in 4 Section where persons were scheduled to install cribs during the oncoming afternoon shift on September 23, 2001. A hazardous condition consisting of inadequate rock dust existed, but was not identified by the examiner. The condition was obvious, widespread, and in the areas traveled by the examiner. During the investigation, mine dust samples were collected throughout 4 Section. These band samples were subjected to an Incombustible Analysis. The results revealed that approximately 97% of the sample results did not meet the regulatory requirements for incombustible content of the combined coal dust, rock dust and other dust. None of the 31 band samples taken in the inby area of 4 Section met the regulatory requirements. The average incombustible content was less than 40%, indicating a condition significantly below the regulatory requirements that should have been recognized by a prudent mine examiner. This area of 4 Section was not flooded during recovery operations and was the location where both explosions originated. This was also the area where coal dust became the primary fuel for the second explosion. The condition contributed to the severity and extent of the second explosion that resulted in fatal injuries. The Order will not be terminated until hazard recognition training is provided for certified mine examiners at the No. 5 Mine.

Citation, 104(a), 75.202(a), S&S, Moderate Negligence. On September 23, 2001, two separate explosions occurred in 4 Section, resulting in fatal injuries to thirteen miners. The accident investigation revealed the roof in the No. 2 entry of 4 Section at the intersection of Survey Station 13333 was not supported or otherwise controlled to protect persons from hazards related to a fall of roof in that area. On Friday, September 21, a crack in the roof was observed, a noise was heard and water was observed dripping from some roof bolt holes at this location. The section coordinator directed the section foreman to have supplemental roof support (cable bolts) installed through the intersection. About sixteen, 10-foot long cable bolts were installed during day shift on Friday. Methane, water, broken coal and broken shale were encountered above the anchorage zone of the primary roof supports (72-inch fully grouted resin bolts). Competent roof was not encountered in the anchorage zone of many of the cable bolt holes, rendering the cable bolts ineffective. An unintentional roof fall occurred in that area on September 23. As the mine roof fell, methane was liberated from the strata into the mine entries. Arcing of a scoop battery that was damaged by the roof fall ignited the methane. The explosion damaged critical ventilation controls and disrupted the airflow. A second explosion resulted in fatal injuries to miners.

## Appendix A – List of Injured Miners

<u>Name</u>	<u>Title</u>	<u>Nature of Injury</u>
Gaston E. Adams, Jr.	LW Machine Operator	Fatally Injured
Raymond F. Ashworth	Belt Repairman	Fatally Injured
Nelson Banks, Jr.	Electrician I/S	Fatally Injured
David L. Blevins	Outby Foreman	Fatally Injured
Clarence H. Boyd	Shearer Operator	Fatally Injured
Wendell R. Johnson	Belt Repairman	Fatally Injured
John W. Knox	U/G Motorman	Fatally Injured
Dennis R. Mobley	Electrician I/S	Fatally Injured
Charles J. Nail	Electrician I/S	Fatally Injured
Sammy J. Riggs	Precision Mason	Fatally Injured
Charles E. Smith	General Labor I/S	Fatally Injured
Joseph P. Sorah	Belt Repairman	Fatally Injured
Terry M. Stewart	General Labor I/S	Fatally Injured
Tony C. Key	Production Foreman	Multiple Contusions
Michael K. McIe	LW Machine Helper	Multiple Contusions
		Fractured Ribs
		Forehead Lacerations
		1 <sup>st</sup> & 2 <sup>nd</sup> Degree Burns
Jim “Skip” Palmer	U/G Motorman	Multiple Contusions
		Laceration to Finger
		Body Trauma

## **Appendix B - Persons Underground at the Time of the Explosion**

<u>Name</u>	<u>Title</u>	<u>Initial Assignments 09/23/01</u>
Gaston E. Adams, Jr.	LW Machine Operator	4 Section Building Cribs
Raymond F. Ashworth	Belt Repairman	Belt Splice 2 East
Alvin L. Bailey	General Labor I/S	Seal Construction
Clarence H. Boyd	Shear Operator	Longwall Maintenance
Nelson Banks, Jr.	Electrician I/S	Maintenance
David L. Blevins	Outby Foreman	Supervisor Outby
Tom R. Connor	General Labor I/S	Seal Construction
George M. Corbin	Electrician I/S	Longwall Maintenance
Jimmy L. Dickerson	General Labor I/S	Longwall Maintenance
Benny E. Franklin	Production Foreman	Supervisor Longwall
B. E. Hallman	General Labor I/S	Belt Splice 2 East
Randy L. Jarvis	General Labor I/S	Fireboss
Wendell R. Johnson	Belt Repairman	Belt Splice 1 East
Christopher Key	Fireboss/Pumper	Pumper
Tony C. Key	Production Foreman	Supervisor No. 4/6 Sections
John W. Knox	U/G Motorman	Rock Dusting Belts
Michael K. McIe	LW Machine Helper	4 Section Building Cribs
Dennis R. Mobley	Electrician I/S	4 Section Maintenance
Charles J. Nail	Electrician I/S	4 Section Maintenance
Charlie L. Ogletree	LW Mach Opr Helper	Longwall Maintenance
Jim "Skip" Palmer	U/G Motorman	Delivering Supplies
Sammy J. Riggs	Precision Mason	Brattice Construction
Vonnie L. Riles	Belt Repairman	Belt Splice 2 East
Douglas G. Robertson	Belt Foreman	Supervisor Belt Splice
Ricky D. Rose	Belt Repairman	Belt Splice 1 East
Stuart L. Sexton	General Labor I/S	Belt Splice 1 East
Jerry L. Short	General Labor I/S	Rock Dusting Belts
Charles E. Smith	General Labor I/S	Labor Work
Joseph P. Sorah	Belt Repairman	Belt Splice 2 East
Terry M. Stewart	General Labor I/S	Labor Work
Robert L. Tarvin	Rock Duster	Rock Dusting Belts
Lonnie R. Willingham	Scoop Operator	Seal Construction

## Appendix C – Mine Rescue Team Members

### Initial Rescue Effort, September 23-24, 2001

John Aldridge	JWR	Greg Franklin	JWR
Mark Aldridge	JWR	Scott Hannig	JWR
Keith Burgess	JWR	Johnny Humphreys	JWR
Dale Byram	JWR	Dale Johnson	JWR
Mike Campbell	JWR	Ken Knight	JWR
Buddy Caudill	JWR	Ricky Lewis	JWR
Ronnie Cearlock	JWR	Larry McGiboney	JWR
Keith Chaney	JWR	John Morse	JWR
Mike Corbin	JWR	Ken Russell	JWR
Dave Dickerson	JWR	Bruce Shores	JWR
Freddie Dickey	JWR	Dave Waldon	JWR
Jerry Elkins	JWR	Charlie Whitehead	JWR
Terry England	JWR		

### Subsequent Recovery Efforts

#### Jim Walter Resources Mine Rescue

Johnny Aldrich	Mark Aldrige
Gary Allison	Ronnie Babb
Kieth Burgess	Dale Byram
Mike Campbell	Buddy Caudill
Ronnie Cearloc	Keith Chaney
Mike Corbin	Dave Dickerson
Freddie Dickey	Russell Dickey
Jerry Elkins	Al England
Terry England	Greg Franklin
Scott Hannig	Johnny Humphreys
Marshal Hutchens	Dale Johnson
Ken Knight	Ray Lee
Ricky Lewis	Larry McGiboney
John Morse	Kenny Nichols
Ricky Pate	Donnie Pennington
Glenn Pierson	Stacy Piper
Carl Poe	Ken Russell
David Shoemaker	Bruce Shores
Craig Slate	Jim Steadman
David Terry	David Waldon
Charlie Whitehead	

**Drummond Mine Rescue**

Robert Cagle  
Tim Hyche  
Kenny Pate  
Eddie Sides  
Buddy Taylor

Rayford Herron  
Larry McDonald  
Jeff Reed  
Tim Stockman

**P. and M. Mine Rescue**

Kevin Cosby  
Donnie Elliot  
Dorsey Lawrence  
Eldon Sides

Steve Cannon  
Terrell Files  
James Sands  
William Smith

**USX Mine Rescue**

David Anderson  
Frank Elliot  
Kenneth Scurlock

Greg Cox  
Vincent Potoka

**Alabama State Mine Rescue**

Tim Bynam  
Ben Jackson  
Ricky McGuire  
Larry Sides  
Randy Weekly  
Joe Weldon

Steve Gann  
Gerry Kimes  
Scott Miles  
Ronald Soneff  
Vince Weeks  
Bee Williams

**MSHA Mine Emergency Unit**

Jerry Bellamy  
Robert Clay  
Ron Costlow  
Stevie Justice  
Jim Langley  
Otis Matthews  
John Mehaulic, Jr.  
Norman Page  
Charles Pogue  
John Reed  
Willie Spens  
Charles Thomas  
Tim Watkins

Virgil Brown  
Gerald Cook, Jr.  
Ron Hixson  
Jeff Kravitz  
Jan Lyall  
Larry Meade  
Joe O'Donnell, Jr.  
Robert Penigar  
Jim Poynter  
Stanley Sampsel  
Ron Taylor  
Ron Tulanowski

## Appendix D – List of Persons Who Provided Voluntary Statements\*

<u>Name</u>	<u>Title</u>
Alvin L. Bailey	General Labor I/S
Eric A. Barnes	SC Operator/Safety Committee
Steven A. Barnes	Rock duster
Lorenzo W. Bonner	Roofbolter
Gregory V. Brown	Production Foreman
Michael C. Buchanan	Production Foreman
Dale Byram	Manager of Safety and Training
Morris W. Canterbury	Electrician I/S
Richard L. Cates	Safety Supervisor
Kenneth R. Clements	SC Operator/Safety Committee
Jessee E. Cooley	Mine Manager
Tom R. Connor	General Labor I/S
George M. Corbin	Electrician I/S
William L. Denson	Master Electrician
Jimmy L. Dickerson	Electrician I/S
Howard B. Duvall	Section Coordinator
Albert J. Dye, Jr.	Pre-Mason Construction
Donald J. Fowler	Haulage Coordinator
Benny E. Franklin	Production Foreman
B. E. Hallman	General Labor I/S
Scott A. Hannig	Rock duster
Leroy Harris	Mining Machine Operator
Harry T. House	CO Room Supervisor
Robert C. Howell	Manager Engineering
Jeffrey D. Jarrell	Electrician I/S
Randy L. Jarvis	General Labor I/S
Larry P. Jessee	Scoop Operator
Arvie D. Key	Communications Supervisor
Christopher Key	Fireboss/Pumper
Tony C. Key	Production Foreman
Charles T. Langley	MSHA Supervisor
Terry L. Lathem	Fireboss
Ricky K. Lewis	Production Foreman
Bruce A. Mabe	Production Foreman
Terry D. Mabe	Trackman I/S
Larry McGiboney	Dust Supervisor (#4 Mine)
Thomas E. McNider	Manager of Ventilation
Charlie L. Ogletree	LW Machine Operator Helper
Richard C. Parker	SC Operator/Safety Committee
James S. Piper	Belt Coordinator

---

\* Other persons provided confidential statements.

Mark A. Piper, Sr.  
John E. Puckett  
Vonnie L. Riles  
Douglas G. Robertson  
Ricky D. Rose  
Charles F. Roubdioux  
Ralph D. Saddler  
Johnny O. Sealy  
Stuart L. Sexton  
Jerry L. Short  
Isaac Smith III  
James W. Smith, Jr.  
Tommy L. Spencer, Sr.  
Robert E. Statham  
Will Tanniehill  
Robert L. Tarvin  
David O. Terry  
Davis T. Thrasher  
Gary W. Toxey  
Yvonne B. Waldon  
John C. Wallace, Jr.  
Randy J. Watts  
Jarvis F. Westery  
Thomas E. Willey  
Lonnie R. Willingham  
James E. Woods  
Milton E. Wren  
Ronald S. Wright

Section Area Manager  
Production Foreman  
Belt Repairman  
Belt Foreman  
Belt Repairman  
General Labor I/S  
General Labor I/S  
Roofbolter  
General Labor I/S  
General Labor I/S  
Electrician I/S  
Rock duster  
Outby Area Manager  
General Service Coordinator  
Outby Foreman  
Rock duster  
Roofbolter  
Deputy Mine Manager  
General Labor I/S/Safety Committee  
Communications Supervisor  
U/G Motorman  
Senior Electrical Engineer  
MSHA Inspector  
Rock duster  
Scoop Operator  
Production Foreman  
Communications Supervisor  
General Labor I/S

## Appendix E – Persons Participating in Investigation

### Jim Walter Resources

<u>Name</u>	<u>Title</u>
George Richmond	President and Chief Operating Officer
Richard A. Donnelly	Vice President Mining Operations
Davis T. Thrasher	Mine Manager
Thomas E. McNider	General Manager Mining Engineer
William T. Marston	Sr. Mining Engineer
Alan B. Ferguson	Mining Engineer
Jens H. Lange	Mining Engineer
Danny R. Hagood	Planning & Mine Engineer
William B. Christians	Deputy Mining Engineer
Frankie C. Lee	Manager Operations Planning
Glenn Smith	Planning Supervisor
Charles C. Stewart	Vice President Engineering
Charles C. Oldle	General Manager Technical Services
Richard M. Katz	Project Engineer
Robert C. Howell	Sr. Plant Engineer
Henry R. Sweeney	Electrical Engineer
Robert E. Statham	General Service Coordinator
Dale E. Byram	Manager of Safety and Training
Richard L. Cates	Supervisor Industrial Relations
Robin G. Dzurino	Area Manager CM Section
James E. Jones	Outby Area Manager
Gregory D. Franklin	Longwall Coordinator
James B. Beasley	AFE Project Manager
Donald J. Fowler	Haulage Coordinator
William E. Trammell	Dust Control Supervisor
Mark A. Piper, Sr.	Belt Coordinator
Larry C. Jordan	Maintenance Training Coordinator
James B. Steadman	Training Instructor
John A. Aldrich	Safety Supervisor
Kenneth R. Russell	Safety Supervisor



## **United Mine Workers of America**

Joseph A. Main	UMWA Administrator
Max W. Kennedy, Jr.	UMWA International Representative
Dennis O'Dell	UMWA International Representative
Edgar Oldham	UMWA International Representative
Jimmy Stevenson	UMWA International Representative
Gary Trout	UMWA International Representative
Thomas F. Wilson	UMWA International Representative
William Cox	UMWA Representative
Tom Sweeten	UMWA Representative
William A. Scott	Mining Machine Operator
Eric A. Barnes	Shuttle Car Operator
Kenneth R. Clements	Shuttle Car Operator
Duke M. Kilgore	Shuttle Car Operator
Richard C. Parker	Shuttle Car Operator
Gary B. Tramell	Electrician
Morris W. Canterbury	Electrician
Benjamin I. Miles	Roof Bolter
Danny E. Hallman	Roof Bolter
Terry Eulenstein	Roofbolter
Daved G. Dickerson	General Labor
Gary W. Toxey	General Labor
Michael D. Boyd	Degas Driller
Randy J. Hall	Degas Driller
Earl M. Brooks	Pre-Mason Construction

## **State of Alabama**

Donald A. Keith	Mine Inspector
Gary D. Key	Mine Inspector

## **MSHA Investigation Team**

Ray McKinney	Administrator, formerly District Manager, District 5
William Crocco	Accident Investigation Program Manager, MSHA Headquarters
Kevin G. Stricklin	Assistant District Manager, District 2
Kenneth A. Murray	Special Assistant to the Administrator, MSHA Headquarters, formerly District 5 Assistant DM

John E. Urosek	Chief, Ventilation Division, Technical Support
Dennis A. Beiter	Supervisory Mining Engineer, Technical Support
Stanley T. Blankenship	Supervisory Special Investigator, District 5
Roy D. Davidson	Supervisory Health and Safety Specialist, District 5
Clete R. Stephan	Principal Mining Engineer, Technical Support
Mark Malecki	Attorney, Office of the Solicitor

**MSHA District 7**

Ronnie J. Deaton	Education Field Services
------------------	--------------------------

**MSHA District 5**

Kimra G. Collier	Program Analyst
Gary L. Roberts	Mine Inspector

**National Mine Health and Safety Academy**

Kenneth M. Scott	Safety Management Branch
------------------	--------------------------

**Pittsburgh Safety and Health Technology Center**

George Aul	Ventilation Division
James Baca	Ventilation Division
Joseph A. Cybulski	Roof Control Division
Kim Diederich	Ventilation Division
William J. Gray	Roof Control Division
Scott Johnson	Ventilation Division
Thomas Morley	Ventilation Division
Mark Pompei	Ventilation Division
Mark Schroeder	Ventilation Division
Gary Shemon	Ventilation Division
Paul L. Tynna	Roof Control Division

**Approval and Certification Center**

Wayne L. Carey  
Kevin L. Hedrick  
Robert J. Holubeck  
Phillip McCabe  
Richard K. Merritt  
Robert S. Setren

Electrical Equipment Branch  
Electrical Safety Division  
Intrinsic Safety & Instrumentation Branch  
Diesel Power Systems Branch  
Diesel Power Systems Branch  
Diesel Power Systems Branch

# Appendix F - Accident Investigation Data - Victim Information

Accident Investigation Data - Victim Information

**U.S. Department of Labor**  
Mine Safety and Health Administration



Event Number: 4 2 9 0 6 7 5

**Victim Information: 1**

1. Name of Injured/Ill Employee: <i>Gaston E. Adams</i>		2. Sex: <i>M</i>	3. Victim's Age: <i>57</i>	4. Last Four Digits of SSN: <i>0000</i>	5. Degree of Injury: <i>01 Fatal</i>											
6. Date(MM/DD/YY) and Time(24 Hr.) Of Death: <i>a. Date: 9/23/2001 b. Time: 18:00</i>				7. Date and Time Started: <i>a. Date: 9/23/2001 b. Time: 15:00</i>												
8. Regular Job Title: <i>064 Longwall Machine Operator Helper</i>			9. Work Activity when Injured: <i>089 Building Cribbs</i>		10. Was this work activity part of regular job? Yes   No   <input checked="" type="checkbox"/> X											
11. Experience		Years	Weeks	Days	b. Regular	Years	Weeks	Days	c. This	Years	Weeks	Days	d. Total	Years	Weeks	Days
a. This Work		<i>0</i>	<i>0</i>	<i>0</i>	Job Title:	<i>4</i>	<i>43</i>	<i>0</i>	Mine:	<i>19</i>	<i>39</i>	<i>3</i>	Mining:	<i>19</i>	<i>39</i>	<i>3</i>
12. What Directly Inflicted Injury or Illness? <i>045 Ignition/Explosion</i>				13. Nature of Injury or Illness: <i>170 Crushing Injuries to Chest and Pelvis</i>												
14. Training Deficiencies: Hazard:           New/Newly-Employed Experienced Miner:           Annual:           Task:																
15. Company of Employment: (If different from production operator) <i>Operator</i>						Independent Contractor ID: (if applicable)										
16. On-site Emergency Medical Treatment: Not Applicable: <input checked="" type="checkbox"/> X   First-Aid:           CPR:           EMT:           Medical Professional:           None:																
17. Part 50 Document Control Number: (form 7000-1)				18. Union Affiliation of Victim: <i>2555 United Mine Workers of Amer.</i>												

**Victim Information: 2**

1. Name of Injured/Ill Employee: <i>Raymond F. Ashworth</i>		2. Sex: <i>M</i>	3. Victim's Age: <i>53</i>	4. Last Four Digits of SSN: <i>0000</i>	5. Degree of Injury: <i>01 Fatal</i>											
6. Date(MM/DD/YY) and Time(24 Hr.) Of Death: <i>a. Date: 9/24/2001 b. Time: 14:30</i>				7. Date and Time Started <i>a. Date: 9/23/2001 b. Time: 15:00</i>												
8. Regular Job Title: <i>001 Belt Repairman</i>			9. Work Activity when Injured: <i>001 Accident Recovery</i>		10. Was this work activity part of regular job? Yes   No   <input checked="" type="checkbox"/> X											
11. Experience		Years	Weeks	Days	b. Regular	Years	Weeks	Days	c. This	Years	Weeks	Days	d. Total	Years	Weeks	Days
a. This Work		<i>0</i>	<i>0</i>	<i>0</i>	Job Title:	<i>2</i>	<i>36</i>	<i>0</i>	Mine:	<i>12</i>	<i>46</i>	<i>2</i>	Mining:	<i>20</i>	<i>0</i>	<i>0</i>
12. What Directly Inflicted Injury or Illness? <i>045 Ignition/Explosion</i>				13. Nature of Injury or Illness: <i>120 Thermal Burns</i>												
14. Training Deficiencies: Hazard:           New/Newly-Employed Experienced Miner:           Annual:           Task:																
15. Company of Employment: (If different from production operator) <i>Operator</i>						Independent Contractor ID: (if applicable)										
16. On-site Emergency Medical Treatment: Not Applicable:           First-Aid: <input checked="" type="checkbox"/> X   CPR:           EMT: <input checked="" type="checkbox"/> X   Medical Professional:           None:																
17. Part 50 Document Control Number: (form 7000-1)				18. Union Affiliation of Victim: <i>2555 United Mine Workers of Amer.</i>												

**Victim Information: 3**

1. Name of Injured/Ill Employee: <i>Nelson Banks</i>		2. Sex: <i>M</i>	3. Victim's Age: <i>53</i>	4. Last Four Digits of SSN: <i>0000</i>	5. Degree of Injury: <i>01 Fatal</i>											
6. Date(MM/DD/YY) and Time(24 Hr.) Of Death: <i>a. Date: 9/23/2001 b. Time: 18:00</i>				7. Date and Time Started <i>a. Date: 9/23/2001 b. Time: 15:00</i>												
8. Regular Job Title: <i>002 Electrician</i>			9. Work Activity when Injured: <i>001 Accident Recovery</i>		10. Was this work activity part of regular job? Yes   No   <input checked="" type="checkbox"/> X											
11. Experience		Years	Weeks	Days	b. Regular	Years	Weeks	Days	c. This	Years	Weeks	Days	d. Total	Years	Weeks	Days
a. This Work		<i>0</i>	<i>0</i>	<i>0</i>	Job Title:	<i>8</i>	<i>19</i>	<i>6</i>	Mine:	<i>1</i>	<i>42</i>	<i>1</i>	Mining:	<i>24</i>	<i>0</i>	<i>0</i>
12. What Directly Inflicted Injury or Illness? <i>045 Ignition/Explosion</i>				13. Nature of Injury or Illness: <i>110 Asphyxia</i>												
14. Training Deficiencies: Hazard:           New/Newly-Employed Experienced Miner:           Annual:           Task:																
15. Company of Employment: (If different from production operator) <i>Operator</i>						Independent Contractor ID: (if applicable)										
16. On-site Emergency Medical Treatment: Not Applicable: <input checked="" type="checkbox"/> X   First-Aid:           CPR:           EMT:           Medical Professional:           None:																
17. Part 50 Document Control Number: (form 7000-1)				18. Union Affiliation of Victim: <i>2555 United Mine Workers of Amer.</i>												

Accident Investigation Data - Victim Information



Event Number: 4 2 9 0 6 7 5

**Victim Information: 4**

1. Name of Injured/Ill Employee: David L. Blevins 2. Sex: M 3. Victim's Age: 52 4. Last Four Digits of SSN: 0000 5. Degree of Injury: 01 Fatal

6. Date(MM/DD/YY) and Time(24 Hr.) Of Death: a. Date: 9/23/2001 b. Time: 18:00 7. Date and Time Started: a. Date: 9/23/2001 b. Time: 15:00

8. Regular Job Title: 049 Section Foreman 9. Work Activity when Injured: 001 Accident Recovery 10. Was this work activity part of regular job? Yes  No  X

11. Experience: Years 0 Weeks 0 Days 0 b. Regular Job Title: 7 4 5 c. This Mine: Years 7 Weeks 4 Days 5 d. Total Mining: Years 12 Weeks 4 Days 5

12. What Directly Inflicted Injury or Illness? 045 Ignition/Explosion 13. Nature of Injury or Illness: 170 Crushing Injuries

14. Training Deficiencies: Hazard:  New/Newly-Employed Experienced Miner:  Annual:  Task:

15. Company of Employment: (If different from production operator) Operator Independent Contractor ID: (if applicable)

16. On-site Emergency Medical Treatment: Not Applicable:  First-Aid:  CPR:  EMT:  Medical Professional:  None:

17. Part 50 Document Control Number: (form 7000-1) 18. Union Affiliation of Victim: 2555 United Mine Workers of Amer.

**Victim Information: 5**

1. Name of Injured/Ill Employee: Clarence H. Boyd 2. Sex: M 3. Victim's Age: 38 4. Last Four Digits of SSN: 0000 5. Degree of Injury: 01 Fatal

6. Date(MM/DD/YY) and Time(24 Hr.) Of Death: a. Date: 9/23/2001 b. Time: 18:00 7. Date and Time Started: a. Date: 9/23/2001 b. Time: 15:00

8. Regular Job Title: 064 Shear Operator 9. Work Activity when Injured: 001 Accident Recovery 10. Was this work activity part of regular job? Yes  No  X

11. Experience: Years 0 Weeks 0 Days 0 b. Regular Job Title: 0 18 4 c. This Mine: Years 14 Weeks 39 Days 4 d. Total Mining: Years 14 Weeks 39 Days 4

12. What Directly Inflicted Injury or Illness? 045 Ignition/Explosion 13. Nature of Injury or Illness: 110 Asphyxia

14. Training Deficiencies: Hazard:  New/Newly-Employed Experienced Miner:  Annual:  Task:

15. Company of Employment: (If different from production operator) Operator Independent Contractor ID: (if applicable)

16. On-site Emergency Medical Treatment: Not Applicable:  First-Aid:  CPR:  EMT:  Medical Professional:  None:

17. Part 50 Document Control Number: (form 7000-1) 18. Union Affiliation of Victim: 2555 United Mine Workers of Amer.

**Victim Information: 6**

1. Name of Injured/Ill Employee: Wendell R. Johnson 2. Sex: M 3. Victim's Age: 52 4. Last Four Digits of SSN: 0000 5. Degree of Injury: 01 Fatal

6. Date(MM/DD/YY) and Time(24 Hr.) Of Death: a. Date: 9/23/2001 b. Time: 18:00 7. Date and Time Started: a. Date: 9/23/2001 b. Time: 15:00

8. Regular Job Title: 001 Belt Repairman 9. Work Activity when Injured: 001 Accident Recovery 10. Was this work activity part of regular job? Yes  No  X

11. Experience: Years 0 Weeks 0 Days 0 b. Regular Job Title: 2 38 4 c. This Mine: Years 2 Weeks 46 Days 2 d. Total Mining: Years 26 Weeks 0 Days 0

12. What Directly Inflicted Injury or Illness? 045 Ignition/Explosion 13. Nature of Injury or Illness: 110 Asphyxia

14. Training Deficiencies: Hazard:  New/Newly-Employed Experienced Miner:  Annual:  Task:

15. Company of Employment: (If different from production operator) Operator Independent Contractor ID: (if applicable)

16. On-site Emergency Medical Treatment: Not Applicable:  First-Aid:  CPR:  EMT:  Medical Professional:  None:

17. Part 50 Document Control Number: (form 7000-1) 18. Union Affiliation of Victim: 2555 United Mine Workers of Amer.

Accident Investigation Data - Victim Information

U.S. Department of Labor  
Mine Safety and Health Administration



Event Number: 4 2 9 0 6 7 5

**Victim Information: 7**

1. Name of Injured/Ill Employee: *John W. Knox* 2. Sex: *M* 3. Victim's Age: *44* 4. Last Four Digits of SSN: *0000* 5. Degree of Injury: *01 Fatal*

6. Date(MM/DD/YY) and Time(24 Hr.) Of Death: *a. Date: 9/23/2001 b. Time: 18:00* 7. Date and Time Started: *a. Date: 9/3/2001 b. Time: 15:00*

8. Regular Job Title: *069 Motorman* 9. Work Activity when Injured: *001 Accident Recovery* 10. Was this work activity part of regular job? Yes  No  X

11. Experience Years Weeks Days a. This Work Activity: *0 0 0* b. Regular Job Title: *7 17 1* c. This Mine: *22 24 0* d. Total Mining: *22 24 0*

12. What Directly Inflicted Injury or Illness? *045 Ignition/Explosion* 13. Nature of Injury or Illness: *110 Asphyxia*

14. Training Deficiencies: Hazard:  New/Newly-Employed Experienced Miner:  Annual:  Task:

15. Company of Employment: (If different from production operator) *Operator* Independent Contractor ID: (if applicable)

16. On-site Emergency Medical Treatment: Not Applicable:  First-Aid:  CPR:  EMT:  Medical Professional:  None:

17. Part 50 Document Control Number: (form 7000-1) 18. Union Affiliation of Victim: *2555 United Mine Workers of Amer.*

**Victim Information: 8**

1. Name of Injured/Ill Employee: *Dennis R. Mobley* 2. Sex: *M* 3. Victim's Age: *56* 4. Last Four Digits of SSN: *0000* 5. Degree of Injury: *01 Fatal*

6. Date(MM/DD/YY) and Time(24 Hr.) Of Death: *a. Date: 9/23/2001 b. Time: 18:00* 7. Date and Time Started: *a. Date: 9/23/2001 b. Time: 15:00*

8. Regular Job Title: *002 Electrician* 9. Work Activity when Injured: *001 Accident Recovery* 10. Was this work activity part of regular job? Yes  No  X

11. Experience Years Weeks Days a. This Work Activity: *0 0 0* b. Regular Job Title: *13 44 3* c. This Mine: *1 12 2* d. Total Mining: *20 0 0*

12. What Directly Inflicted Injury or Illness? *045 Ignition/Explosion* 13. Nature of Injury or Illness: *110 Asphyxia*

14. Training Deficiencies: Hazard:  New/Newly-Employed Experienced Miner:  Annual:  Task:

15. Company of Employment: (If different from production operator) *Operator* Independent Contractor ID: (if applicable)

16. On-site Emergency Medical Treatment: Not Applicable:  First-Aid:  CPR:  EMT:  Medical Professional:  None:

17. Part 50 Document Control Number: (form 7000-1) 18. Union Affiliation of Victim: *2555 United Mine Workers of Amer.*

**Victim Information: 9**

1. Name of Injured/Ill Employee: *Charles J. Nail* 2. Sex: *M* 3. Victim's Age: *59* 4. Last Four Digits of SSN: *0000* 5. Degree of Injury: *01 Fatal*

6. Date(MM/DD/YY) and Time(24 Hr.) Of Death: *a. Date: 9/23/2001 b. Time: 18:00* 7. Date and Time Started: *a. Date: 9/23/2001 b. Time: 15:00*

8. Regular Job Title: *002 Electrician* 9. Work Activity when Injured: *001 Accident Recovery* 10. Was this work activity part of regular job? Yes  No  X

11. Experience Years Weeks Days a. This Work Activity: *0 0 0* b. Regular Job Title: *11 14 4* c. This Mine: *3 6 4* d. Total Mining: *23 24 0*

12. What Directly Inflicted Injury or Illness? *045 Ignition/Explosion* 13. Nature of Injury or Illness: *110 Asphyxia*

14. Training Deficiencies: Hazard:  New/Newly-Employed Experienced Miner:  Annual:  Task:

15. Company of Employment: (If different from production operator) *Operator* Independent Contractor ID: (if applicable)

16. On-site Emergency Medical Treatment: Not Applicable:  First-Aid:  CPR:  EMT:  Medical Professional:  None:

17. Part 50 Document Control Number: (form 7000-1) 18. Union Affiliation of Victim: *2555 United Mine Workers of Amer.*

Accident Investigation Data - Victim Information



Event Number: 4 2 9 0 6 7 5

**Victim Information: 10**

1. Name of Injured/Ill Employee: Sammy J. Riggs 2. Sex: M 3. Victim's Age: 51 4. Last Four Digits of SSN: 0000 5. Degree of Injury: 01 Fatal

6. Date(MM/DD/YY) and Time(24 Hr.) Of Death: a. Date: 9/23/2001 b. Time: 18:00 7. Date and Time Started: a. Date: 9/23/2001 b. Time: 15:00

8. Regular Job Title: 008 Pre Mason Construction 9. Work Activity when Injured: 001 Accident Recovery 10. Was this work activity part of regular job? Yes  No  X

11. Experience: Years Weeks Days b. Regular Years Weeks Days c. This Years Weeks Days d. Total Years Weeks Days  
 a. This Work Activity: 0 0 0 Job Title: 1 40 0 Mine: 2 46 2 Mining: 16 0 0

12. What Directly Inflicted Injury or Illness? 045 Ignition/Explosion 13. Nature of Injury or Illness: 110 Asphyxia

14. Training Deficiencies: Hazard:  New/Newly-Employed Experienced Miner:  Annual:  Task:

15. Company of Employment: (If different from production operator) Operator Independent Contractor ID: (if applicable)

16. On-site Emergency Medical Treatment: Not Applicable:  First-Aid:  CPR:  EMT:  Medical Professional:  None:

17. Part 50 Document Control Number: (form 7000-1) 18. Union Affiliation of Victim: 2555 United Mine Workers of Amer.

**Victim Information: 11**

1. Name of Injured/Ill Employee: Joseph P. Sarah 2. Sex: M 3. Victim's Age: 46 4. Last Four Digits of SSN: 0000 5. Degree of Injury: 01 Fatal

6. Date(MM/DD/YY) and Time(24 Hr.) Of Death: a. Date: 9/23/2001 b. Time: 18:00 7. Date and Time Started: a. Date: 9/23/2001 b. Time: 15:00

8. Regular Job Title: 035 Miner Helper 9. Work Activity when Injured: 001 Accident Recovery 10. Was this work activity part of regular job? Yes  No  X

11. Experience: Years Weeks Days b. Regular Years Weeks Days c. This Years Week Days d. Total Years Weeks Days  
 a. This Work Activity: 0 0 0 Job Title: 0 3 0 Mine: 4 47 4 Mining: 11 0 0

12. What Directly Inflicted Injury or Illness? 045 Ignition/Explosion 13. Nature of Injury or Illness: 110 Asphyxia

14. Training Deficiencies: Hazard:  New/Newly-Employed Experienced Miner:  Annual:  Task:

15. Company of Employment: (If different from production operator) Operator Independent Contractor ID: (if applicable)

16. On-site Emergency Medical Treatment: Not Applicable:  First-Aid:  CPR:  EMT:  Medical Professional:  None:

17. Part 50 Document Control Number: (form 7000-1) 18. Union Affiliation of Victim: 2555 United Mine Workers of Amer.

**Victim Information: 12**

1. Name of Injured/Ill Employee: Charles E. Smith 2. Sex: M 3. Victim's Age: 44 4. Last Four Digits of SSN: 0000 5. Degree of Injury: 01 Fatal

6. Date(MM/DD/YY) and Time(24 Hr.) Of Death: a. Date: 9/23/2001 b. Time: 18:00 7. Date and Time Started: a. Date: 9/23/2001 b. Time: 15:00

8. Regular Job Title: 016 General Labor 9. Work Activity when Injured: 001 Accident Recovery 10. Was this work activity part of regular job? Yes  No  X

11. Experience: Years Weeks Days b. Regular Years Weeks Days c. This Years Week Days d. Total Years Weeks Days  
 a. This Work Activity: 0 0 0 Job Title: 2 25 6 Mine: 1 44 3 Mining: 7 0 0

12. What Directly Inflicted Injury or Illness? 045 Ignition/Explosion 13. Nature of Injury or Illness: 110 Asphyxia

14. Training Deficiencies: Hazard:  New/Newly-Employed Experienced Miner:  Annual:  Task:

15. Company of Employment: (If different from production operator) Operator Independent Contractor ID: (if applicable)

16. On-site Emergency Medical Treatment: Not Applicable:  First-Aid:  CPR:  EMT:  Medical Professional:  None:

17. Part 50 Document Control Number: (form 7000-1) 18. Union Affiliation of Victim: 2555 United Mine Workers of Amer.



Accident Investigation Data - Victim Information

U.S. Department of Labor  
Mine Safety and Health Administration



Event Number: 4 2 9 0 6 7 5

Victim Information: 13

1. Name of Injured/III Employee: Terry M. Stewart		2. Sex M	3. Victim's Age 44	4. Last Four Digits of SSN: 0000	5. Degree of Injury: 01 Fatal											
6. Date(MM/DD/YY) and Time(24 Hr.) Of Death: a. Date: 9/23/2001 b. Time: 18:00				7. Date and Time Started: a. Date: 9/23/2001 b. Time: 15:00												
8. Regular Job Title: 016 General Labor			9. Work Activity when Injured: 001 Accident Recovery			10. Was this work activity part of regular job? Yes No <input checked="" type="checkbox"/>										
11. Experience		Years	Weeks	Days	b. Regular	Years	Weeks	Days	c. This	Years	Weeks	Days	d. Total	Years	Weeks	Days
a. This Work Activity:		0	0	0	Job Title:	7	4	4	Mine:	0	12	3	Mining:	17	36	0
12. What Directly Inflicted Injury or Illness? 045 Ignition/Explosion									13. Nature of Injury or Illness: 110 Asphyxia							
14. Training Deficiencies: Hazard: _____						New/Newly-Employed Experienced Miner: _____			Annual: _____		Task: _____					
15. Company of Employment: (If different from production operator) Operator										Independent Contractor ID: (if applicable)						
16. On-site Emergency Medical Treatment: Not Applicable: <input checked="" type="checkbox"/> First-Aid: _____ CPR: _____ EMT: _____ Medical Professional: _____ None: _____																
17. Part 50 Document Control Number: (form 7000-1)										18. Union Affiliation of Victim: 2555 United Mine Workers of Amer.						

Victim Information: 14

1. Name of Injured/III Employee: Tony C. Key		2. Sex M	3. Victim's Age 50	4. Last Four Digits of SSN: 0000	5. Degree of Injury: 03 Days away from work only											
6. Date(MM/DD/YY) and Time(24 Hr.) Of Death:				7. Date and Time Started a. Date: 9/23/2001 b. Time: 15:00												
8. Regular Job Title: 049 Production Foreman			9. Work Activity when Injured: 087 Supervise			10. Was this work activity part of regular job? Yes <input checked="" type="checkbox"/> No										
11. Experience		Years	Weeks	Days	b. Regular	Years	Weeks	Days	c. This	Years	Week	Days	d. Total	Years	Weeks	Days
a. This Work Activity:		3	0	0	Job Title:	3	0	0	Mine:	18	0	0	Mining:	26	0	0
12. What Directly Inflicted Injury or Illness? 045 Ignition/Explosion									13. Nature of Injury or Illness: 160 Multiple Contusions							
14. Training Deficiencies: Hazard: _____						New/Newly-Employed Experienced Miner: _____			Annual: _____		Task: _____					
15. Company of Employment: (If different from production operator) Operator										Independent Contractor ID: (if applicable)						
16. On-site Emergency Medical Treatment: Not Applicable: _____ First-Aid: <input checked="" type="checkbox"/> CPR: _____ EMT: _____ Medical Professional: _____ None: _____																
17. Part 50 Document Control Number: (form 7000-1)										18. Union Affiliation of Victim:						

Victim Information: 15

1. Name of Injured/III Employee: Michael K. Mcle		2. Sex M	3. Victim's Age 42	4. Last Four Digits of SSN: 0000	5. Degree of Injury: 03 Days away from work only											
6. Date(MM/DD/YY) and Time(24 Hr.) Of Death:				7. Date and Time Started a. Date: 9/23/2001 b. Time: 15:00												
8. Regular Job Title: 041 Longwall Machine Helper			9. Work Activity when Injured: 089 Building Cribs			10. Was this work activity part of regular job? Yes No <input checked="" type="checkbox"/>										
11. Experience		Years	Weeks	Days	b. Regular	Years	Weeks	Days	c. This	Years	Week	Days	d. Total	Years	Weeks	Days
a. This Work Activity:		0	0	0	Job Title:	4	0	0	Mine:	5	8	0	Mining:	12	0	0
12. What Directly Inflicted Injury or Illness? 045 Ignition/Explosion									13. Nature of Injury or Illness: 160 Multiple Contusions/Burns							
14. Training Deficiencies: Hazard: _____						New/Newly-Employed Experienced Miner: _____			Annual: _____		Task: _____					
15. Company of Employment: (If different from production operator) Operator										Independent Contractor ID: (if applicable)						
16. On-site Emergency Medical Treatment: Not Applicable: _____ First-Aid: <input checked="" type="checkbox"/> CPR: _____ EMT: _____ Medical Professional: _____ None: _____																
17. Part 50 Document Control Number: (form 7000-1)										18. Union Affiliation of Victim: 2555 United Mine Workers of Amer.						



Accident Investigation Data - Victim Information



Event Number: 4 2 9 0 6 7 5

Victim Information: 16

1. Name of Injured/III Employee: Jim "Skip" Palmer  
2. Sex: M  
3. Victim's Age: 48  
4. Last Four Digits of SSN: 0000  
5. Degree of Injury: 03 Days away from work only

6. Date(MM/DD/YY) and Time(24 Hr.) Of Death:  
7. Date and Time Started: a. Date: 9/23/2001 b. Time: 15:00

8. Regular Job Title: 069 Motorman  
9. Work Activity when Injured: 028 Delivering Supplies  
10. Was this work activity part of regular job? Yes  No

11. Experience: Years Weeks Days  
a. This Work Activity: 12 0 0  
b. Regular Job Title: 12 0 0  
c. This Mine: 21 0 0  
d. Total Mining: 29 0 0

12. What Directly Inflicted Injury or Illness? 045 Ignition/Explosion  
13. Nature of Injury or Illness: 160 Multiple Contusions

14. Training Deficiencies: Hazard: New/Newly-Employed Experienced Miner: Annual: Task:

15. Company of Employment: (if different from production operator) Operator  
Independent Contractor ID: (if applicable)

16. On-site Emergency Medical Treatment: Not Applicable: First-Aid:  CPR: EMT: Medical Professional: None:

17. Part 50 Document Control Number: (form 7000-1)  
18. Union Affiliation of Victim: 2555 United Mine Workers of Amer.

Victim Information:

1. Name of Injured/III Employee:  
2. Sex:  
3. Victim's Age:  
4. Last Four Digits of SSN:  
5. Degree of Injury:

6. Date(MM/DD/YY) and Time(24 Hr.) Of Death:  
7. Date and Time Started:

8. Regular Job Title:  
9. Work Activity when Injured:  
10. Was this work activity part of regular job? Yes  No

11. Experience: Years Weeks Days  
a. This Work Activity:  
b. Regular Job Title:  
c. This Mine:  
d. Total Mining:

12. What Directly Inflicted Injury or Illness?  
13. Nature of Injury or Illness:

14. Training Deficiencies: Hazard: New/Newly-Employed Experienced Miner: Annual: Task:

15. Company of Employment: (if different from production operator)  
Independent Contractor ID: (if applicable)

16. On-site Emergency Medical Treatment: Not Applicable: First-Aid: CPR: EMT: Medical Professional: None:

17. Part 50 Document Control Number: (form 7000-1)  
18. Union Affiliation of Victim:

Victim Information:

1. Name of Injured/III Employee:  
2. Sex:  
3. Victim's Age:  
4. Last Four Digits of SSN:  
5. Degree of Injury:

6. Date(MM/DD/YY) and Time(24 Hr.) Of Death:  
7. Date and Time Started:

8. Regular Job Title:  
9. Work Activity when Injured:  
10. Was this work activity part of regular job? Yes  No

11. Experience: Years Weeks Days  
a. This Work Activity:  
b. Regular Job Title:  
c. This Mine:  
d. Total Mining:

12. What Directly Inflicted Injury or Illness?  
13. Nature of Injury or Illness:

14. Training Deficiencies: Hazard: New/Newly-Employed Experienced Miner: Annual: Task:

15. Company of Employment: (if different from production operator)  
Independent Contractor ID: (if applicable)

16. On-site Emergency Medical Treatment: Not Applicable: First-Aid: CPR: EMT: Medical Professional: None:

17. Part 50 Document Control Number: (form 7000-1)  
18. Union Affiliation of Victim:

# Appendix G - Chart - Mine Management Structure

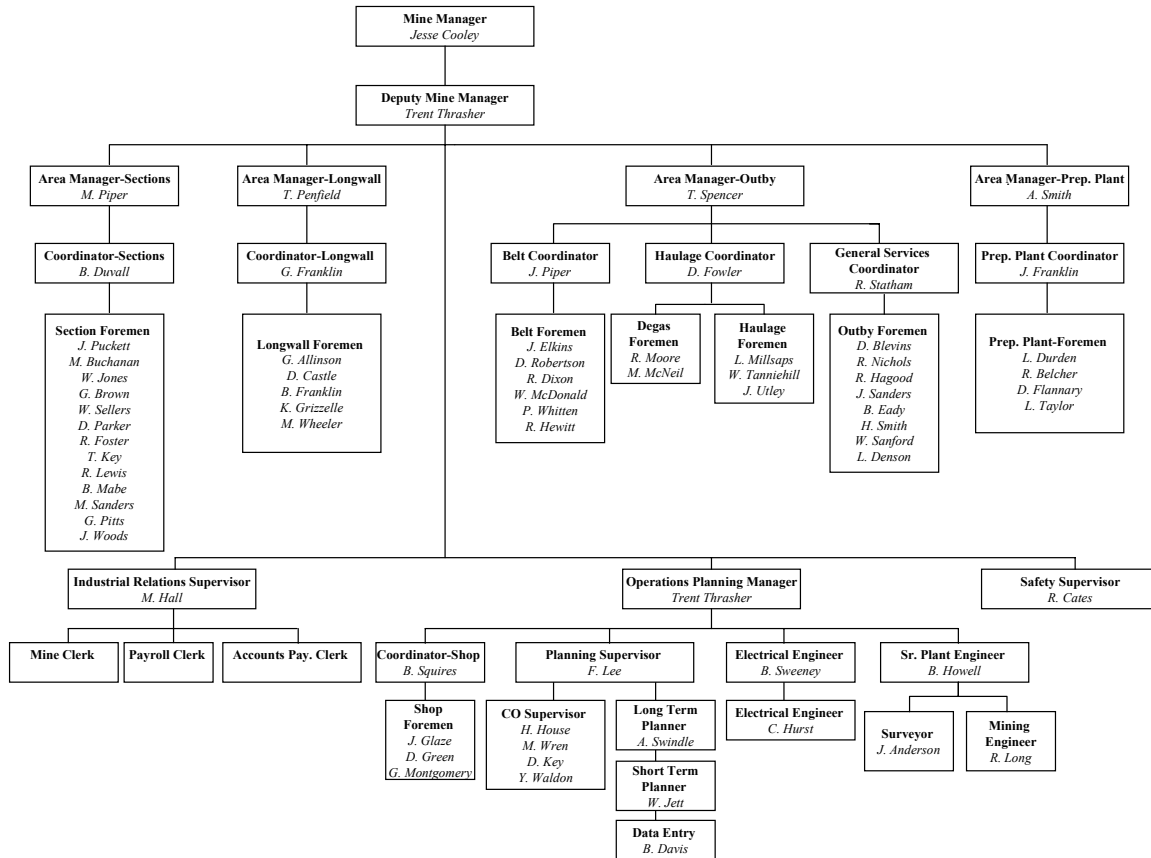



ADJACENT MINE

ADJACENT MINE

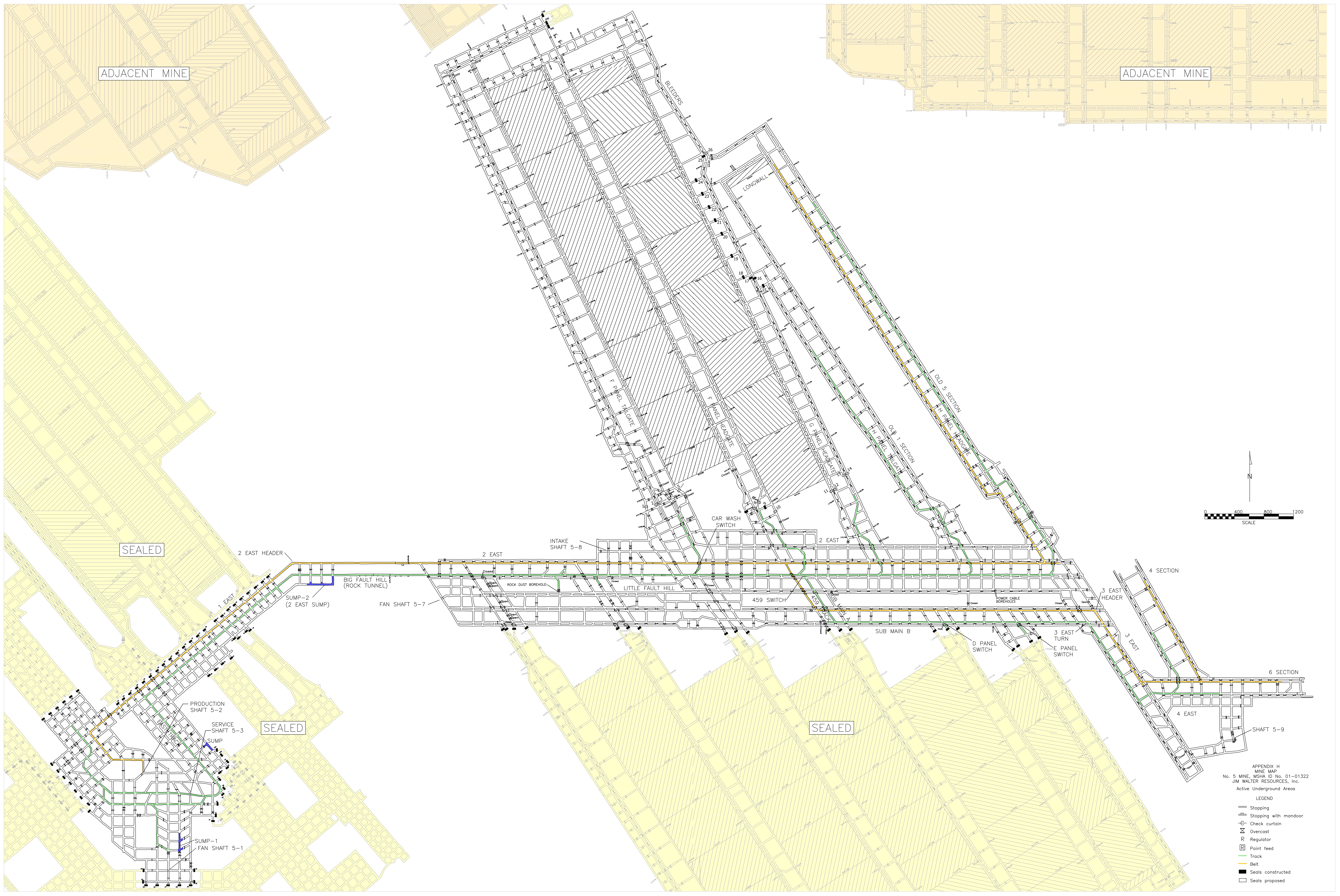
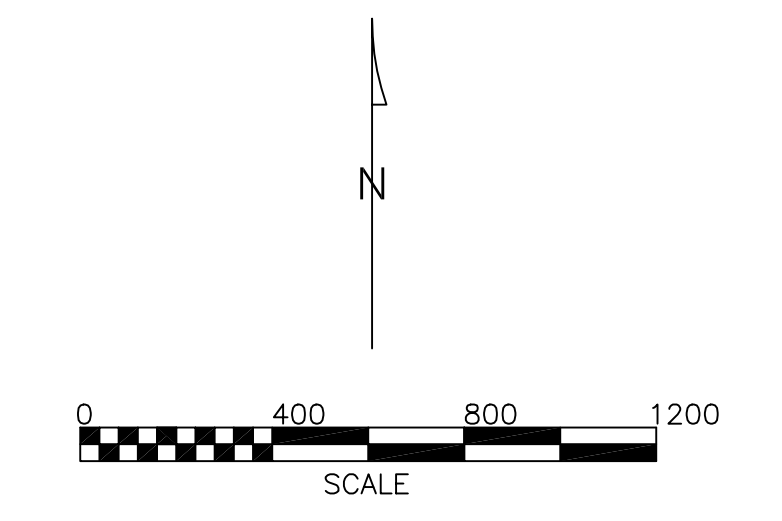

- APPENDIX H  
MINE MAP  
No. 5 MINE, MSHA ID No. 01-01322  
JIM WALTER RESOURCES, Inc.  
Active Underground Areas
- LEGEND
- Stopping
  - Stopping with mandoor
  - ⊖ Check curtain
  - ⊗ Overcast
  - R Regulator
  - ⊠ Point feed
  - Track
  - Belt
  - Seals constructed
  - Seals proposed







ADJACENT MINE

ADJACENT MINE

APPENDIX J  
 MINE MAP  
 No. 5 MINE, MSHA ID No. 01-01322  
 JIM WALTER RESOURCES, Inc.

Approximate Locations of Underground Personnel at Time of Second Explosion

LEGEND

- Track
- Belt
- Seals constructed
- Seals proposed
- \* Victim, injuries fatal
- \*\* Victim, injuries not immediately fatal
- \*\*\* Victim, injuries fatal (possibly from first explosion)

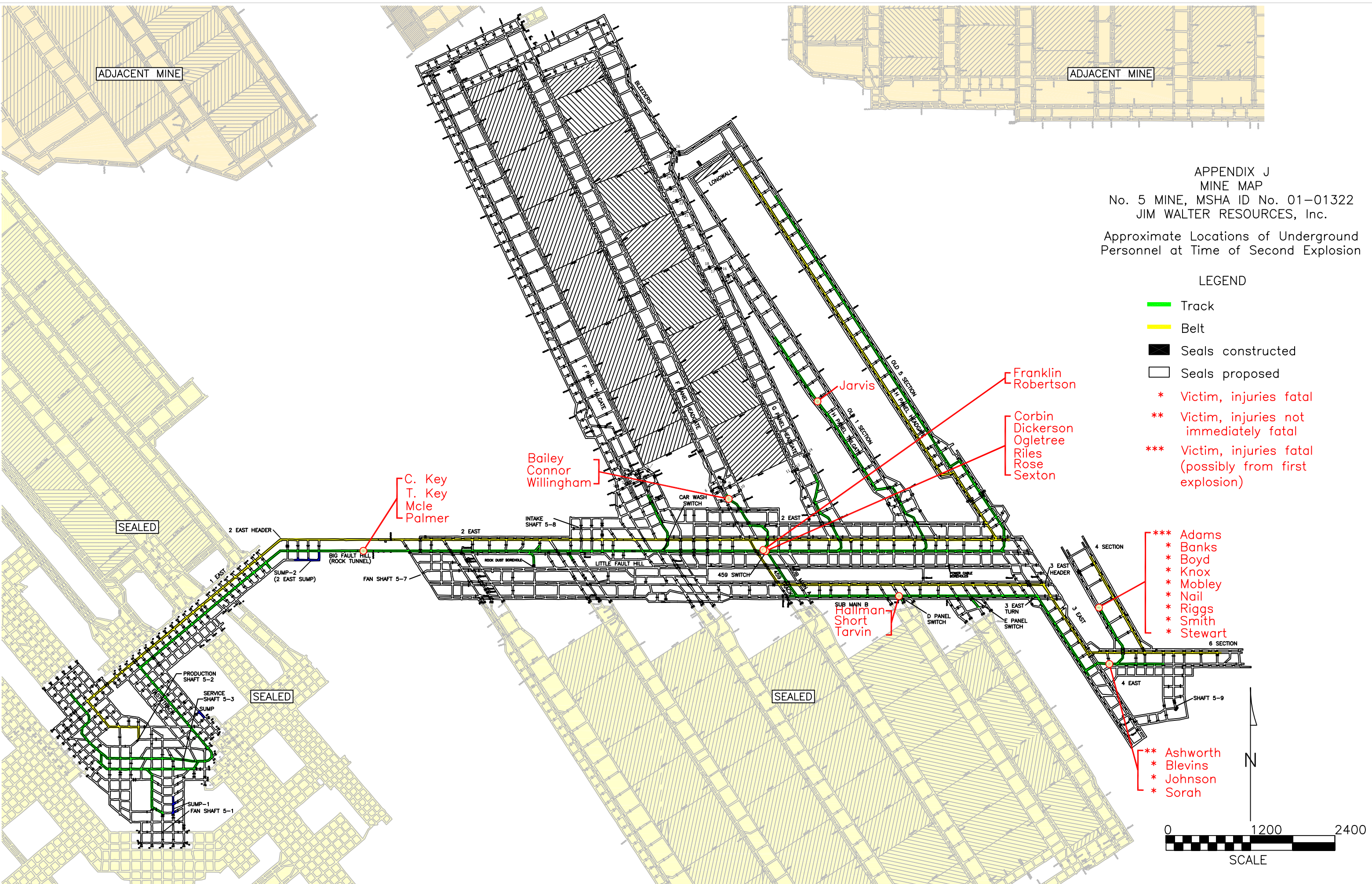

C. Key  
 T. Key  
 Mcle  
 Palmer

Bailey  
 Connor  
 Willingham

Hallman  
 Short  
 Tarvin

Jarvis

Franklin  
 Robertson

Corbin  
 Dickerson  
 Ogletree  
 Riles  
 Rose  
 Sexton

\*\*\* Adams  
 \* Banks  
 \* Boyd  
 \* Knox  
 \* Mobley  
 \* Nail  
 \* Riggs  
 \* Smith  
 \* Stewart

\*\* Ashworth  
 \* Blevins  
 \* Johnson  
 \* Sorah

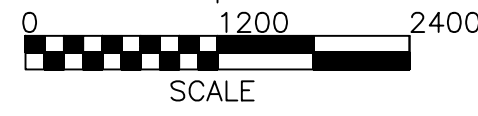





VERTICAL SAMPLING  
AND DEGASIFICATION  
BOREHOLE

APPENDIX K  
MINE MAP  
No. 5 MINE, MSHA ID No. 01-01322  
JIM WALTER RESOURCES, Inc.

Extent of Flooding  
During Recovery

LEGEND

-  Stopping
-  Stopping with mandoor
-  Check curtain
-  Overcast
-  Regulator
-  Point feed
-  Track
-  Belt
-  Flooded area

Note: Damage to ventilation  
controls is orange in color

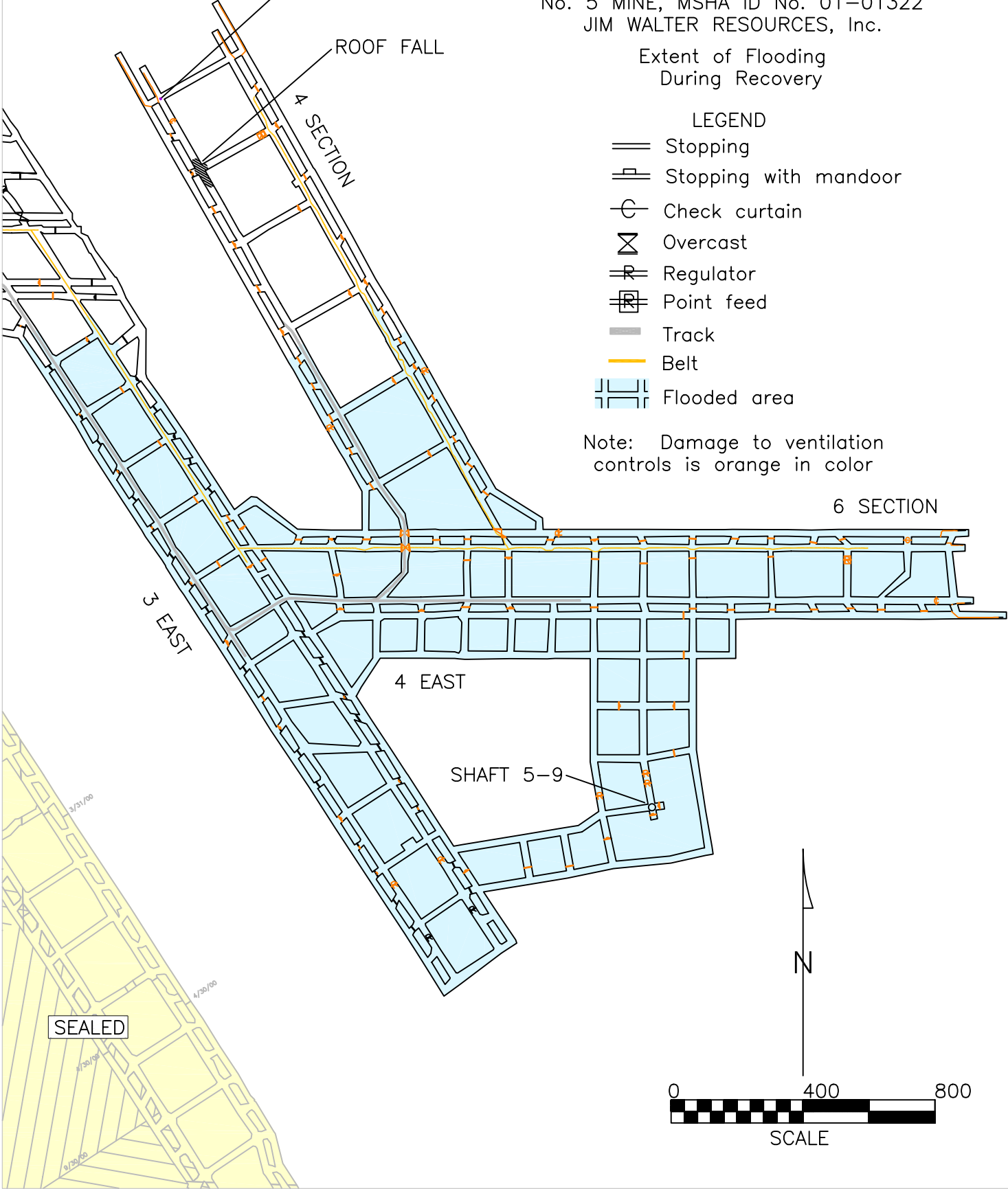

6 SECTION

3 EAST

4 EAST

SHAFT 5-9

SEALED

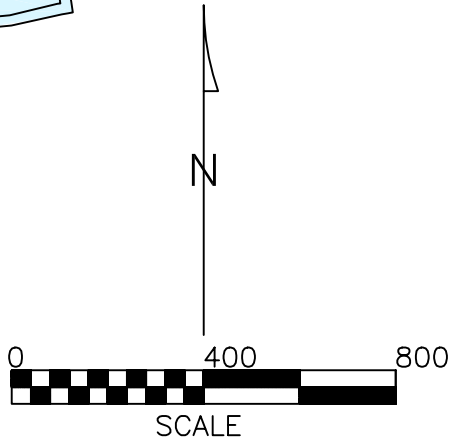



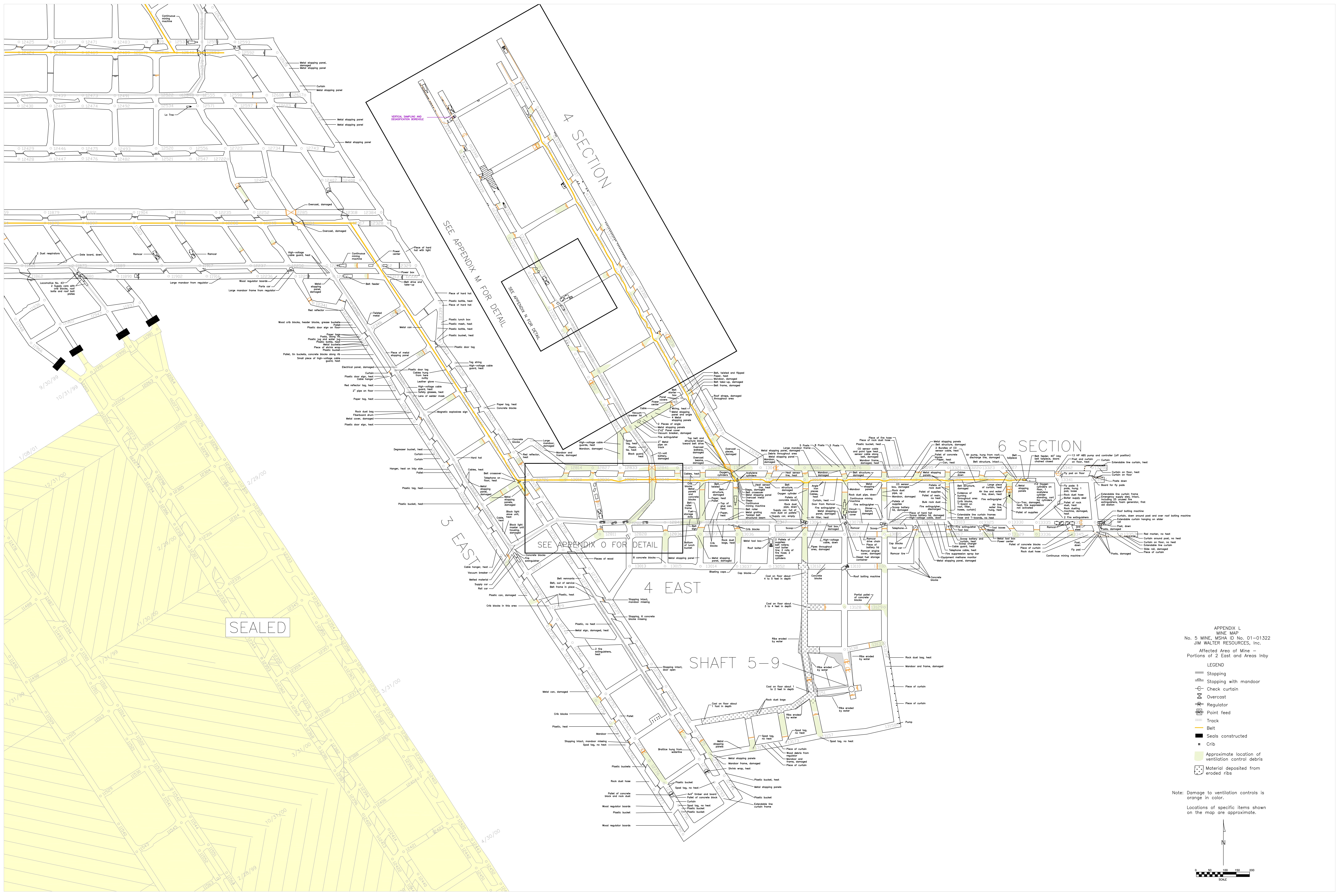

SEALED

3 EAST

4 SECTION

4 EAST

SHAFT 5-9

6 SECTION

APPENDIX L  
MINE MAP  
No. 5 MINE, MSHA ID No. 01-01322  
J.M. WALTER RESOURCES, Inc.  
Affected Area of Mine -  
Portions of 2 East and Areas Inby

- LEGEND
- ≡ Stopping
  - ≡≡ Stopping with mandoor
  - ⊗ Check curtain
  - ⊗ Overcast
  - ⊗ Regulator
  - ⊗ Point feed
  - Track
  - Belt
  - Seals constructed
  - Crib
  - Approximate location of ventilation control debris
  - Material deposited from eroded ribs

Note: Damage to ventilation controls is orange in color.  
Locations of specific items shown on the map are approximate.

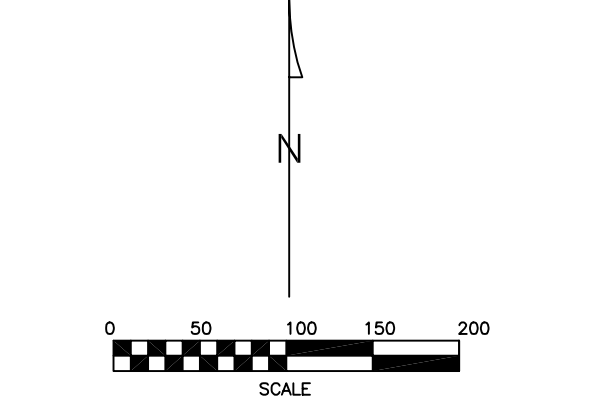



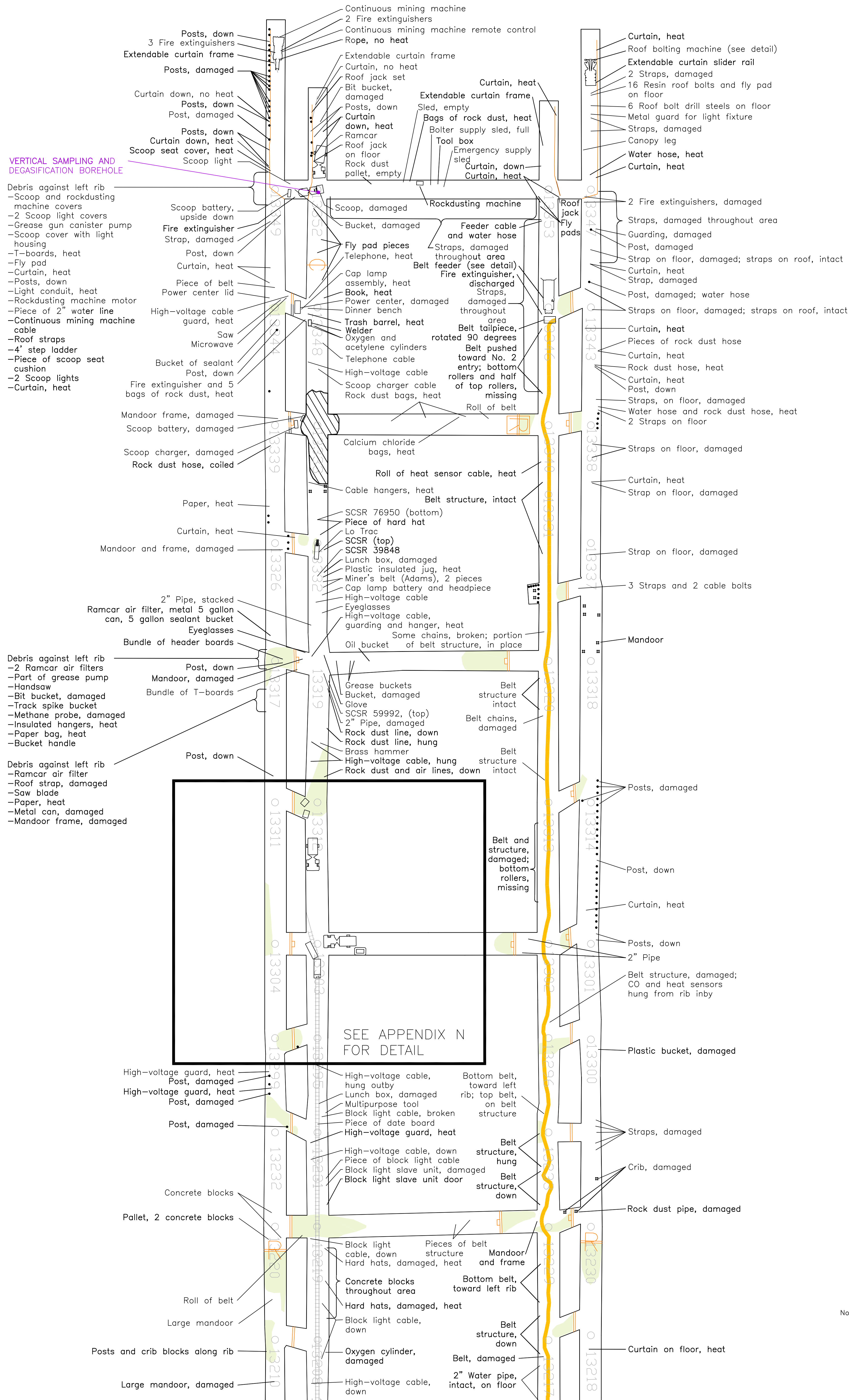

- Roof Bolting Machine**
- Power cable pulled out
  - Canopy broken and collapsed
  - Right-side bolting tray missing
  - Several controls, damaged
  - Machine covers, torn off and overturned
  - Cooling fan, damaged
  - ATRS lights, damaged
  - Tail reflectors, damaged
  - Resin tube, heat
  - Lighting diagram, heat

- Belt Feeder**
- Covers damaged
  - Sideboard plates damaged
  - Spray bars, damaged
  - Guarding, damaged
  - Cover displaced 35' outby

VERTICAL SAMPLING AND DEGASIFICATION BOREHOLE

- Debris against left rib
- Scoop and rockdusting machine covers
- 2 Scoop light covers
- Grease gun canister pump
- Scoop cover with light housing
- T-boards, heat
- Fly pad
- Curtain, heat
- Posts, down
- Light conduit, heat
- Rockdusting machine motor
- Piece of 2" water line
- Continuous mining machine cable
- Roof straps
- 4' step ladder
- Piece of scoop seat cushion
- 2 Scoop lights
- Curtain, heat

- Debris against left rib
- 2 Ramcar air filters
- Part of grease pump
- Handsaw
- Bit bucket, damaged
- Track spike bucket
- Methane probe, damaged
- Insulated hangers, heat
- Paper bag, heat
- Bucket handle

- Debris against left rib
- Ramcar air filter
- Roof strap, damaged
- Saw blade
- Paper, heat
- Metal can, damaged
- Mandoor frame, damaged

APPENDIX M  
MINE MAP  
No. 5 MINE, MSHA ID No. 01-01322  
JIM WALTER RESOURCES, Inc.  
Affected Area of Mine -  
Detail of 4 Section

- LEGEND**
- Stopping
  - Stopping with mandoor
  - Check curtain
  - Regulator
  - Point feed
  - Track
  - Belt
  - Post
  - Crib
  - Roof fall
  - Approximate location of ventilation control debris

Note: Damage to ventilation controls is orange in color.

Locations of specific items shown on the map are approximate.

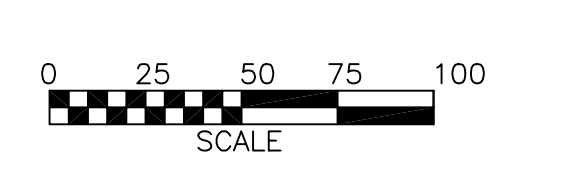



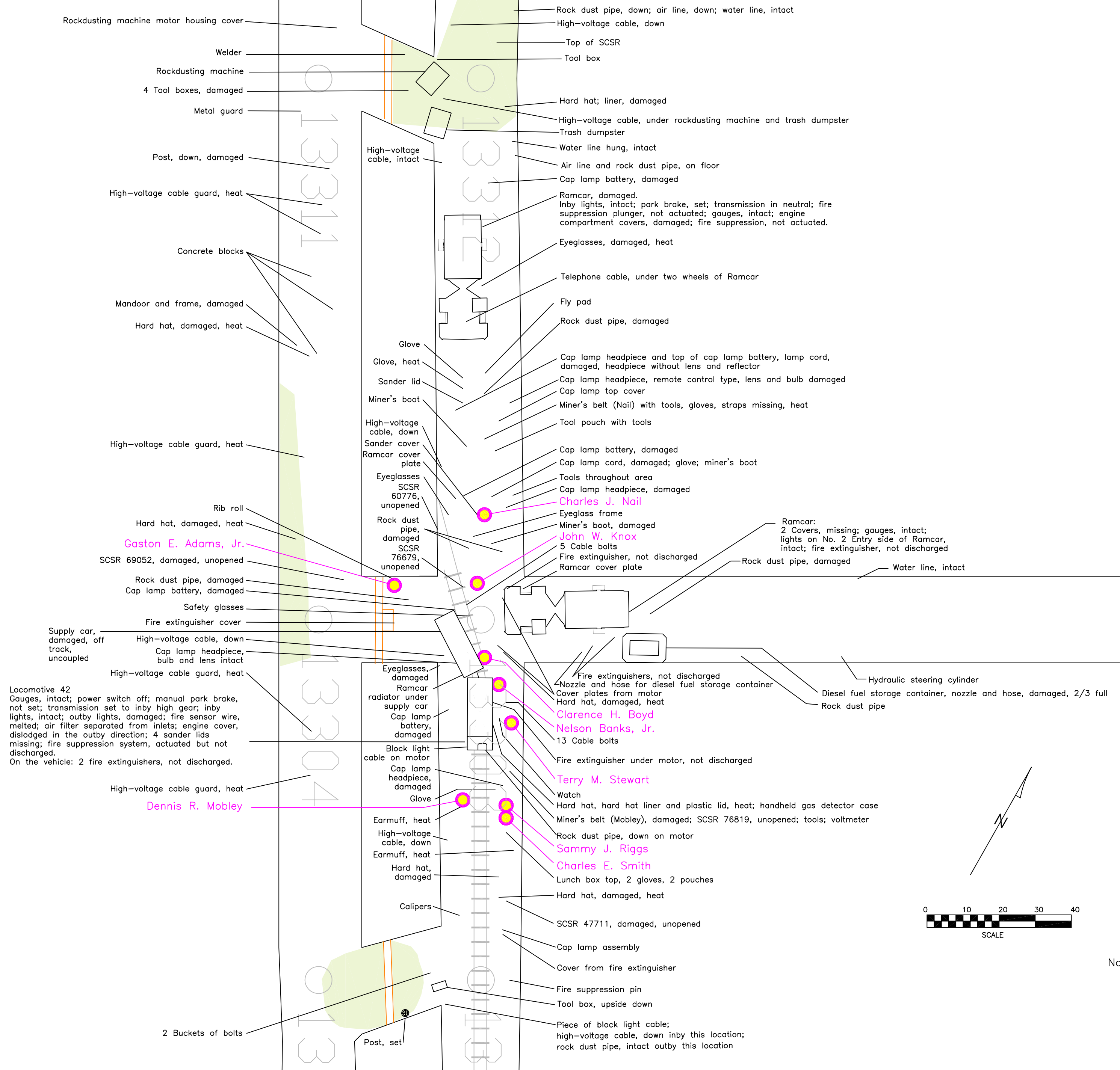

APPENDIX N  
MINE MAP  
No. 5 MINE, MSHA ID No. 01-01322  
JIM WALTER RESOURCES, Inc.  
Affected Area of Mine –  
Detail of Area Surrounding  
End of 4 Section Track

- LEGEND
- == Stopping
  - == Stopping with mandoor
  - Track
  - Approximate location of victim
  - Approximate location of ventilation control debris

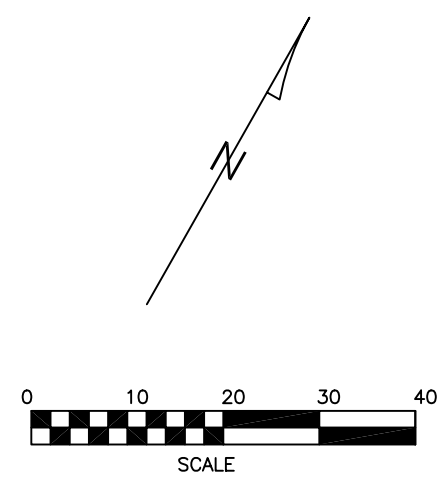

Note: Damage to ventilation controls is orange in color.  
Locations of specific items shown on the map are approximate.



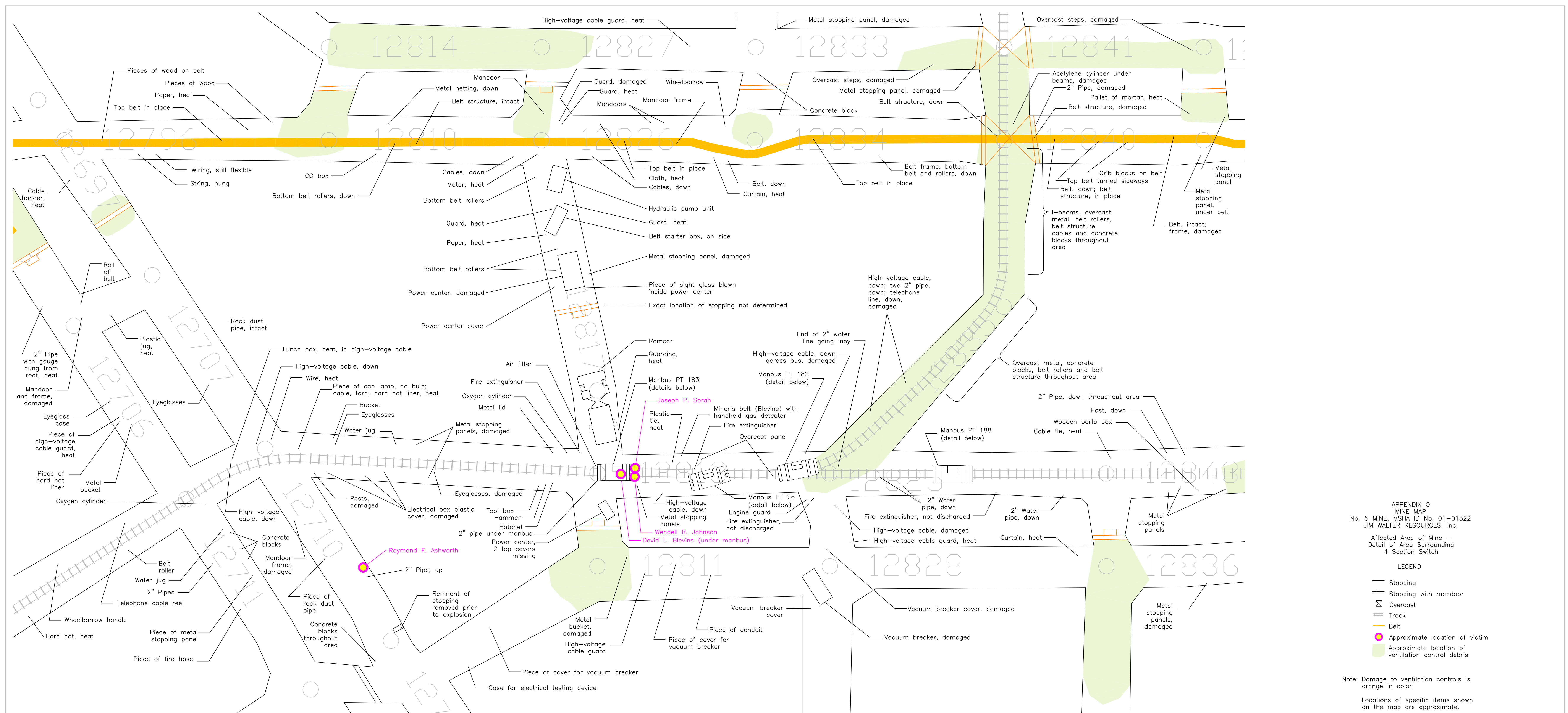

APPENDIX O  
 MINE MAP  
 No. 5 MINE, MSHA ID No. 01-01322  
 JIM WALTER RESOURCES, Inc.  
 Affected Area of Mine -  
 Detail of Area Surrounding  
 4 Section Switch

LEGEND

- ≡ Stopping
- ⊞ Stopping with mandoor
- ⊞ Overcast
- ⊞ Track
- Belt
- Approximate location of victim
- Approximate location of ventilation control debris

Note: Damage to ventilation controls is orange in color.  
 Locations of specific items shown on the map are approximate.

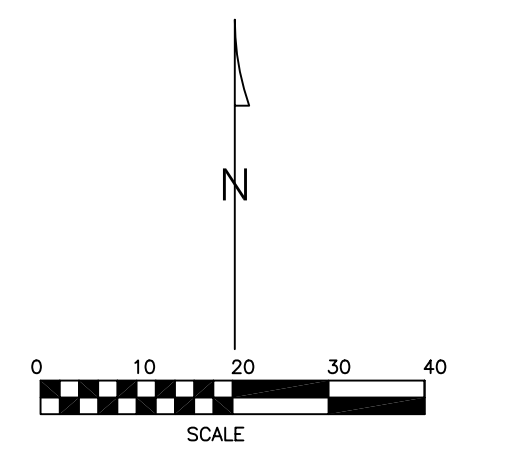

**Manbus PT 183**  
 Outby end reflectors and lights, intact; inby end reflectors, damaged; one inby end light, intact. Vehicle off track. On the vehicle: four fire extinguishers; one handheld gas detector; various tools; shirt, heat.

**Manbus PT 26**  
 Both inby and outby lights, damaged; metal operator's seat, damaged; guard and sander box, damaged; inby side seat covers, heat. Vehicle off track. In operator's compartment: directional switch in off position; light switch in on position for outby side lights. On the vehicle: jack; empty first aid box; two fire extinguishers.





**Manbus PT 182**  
 Engine and transmission covers, damaged; transmission cover, displaced; inby lights, damaged; outby lights, intact; inby wheels off track. In operator's compartment: directional switch inby; inby lights on; park brake released. On the vehicle: two fire extinguishers (not discharged); tools scattered throughout outby compartment; tool pouch, heat.

**Manbus PT 188**  
 Fire suppression and park brake systems, damaged, heat. In operator's compartment: directional switch in off position; light switch in on position for outby side lights; park brake set. On the vehicle: fire extinguisher and first aid kit, intact.

APPENDIX P  
MINE MAP  
No. 5 MINE, MSHA ID No. 01-01322  
JIM WALTER RESOURCES, Inc.

Flame and Forces in Immediate  
Area Affected by First Explosion

LEGEND

-  Extent of flame
-  Direction of primary forces
-  Track
-  Belt

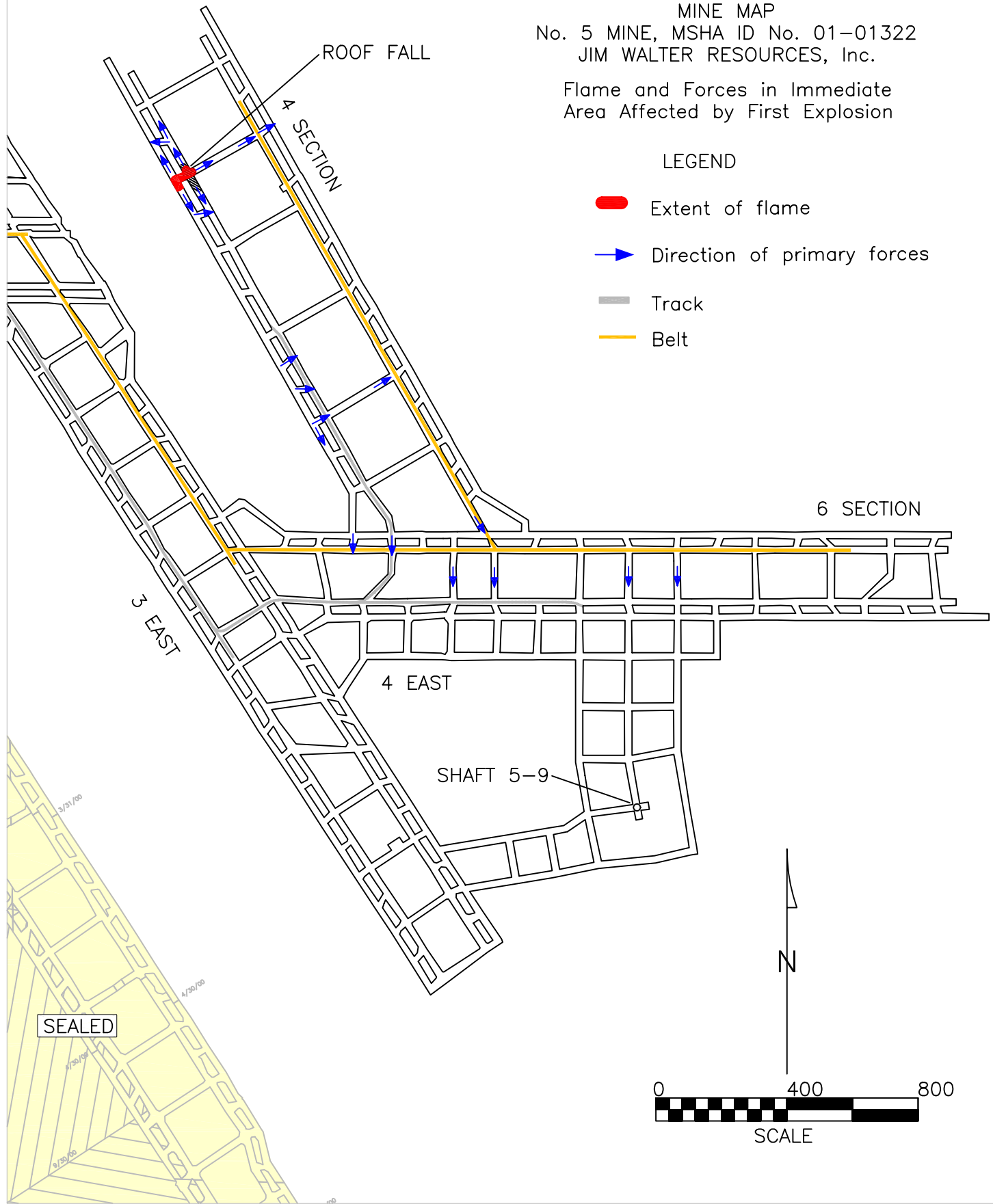



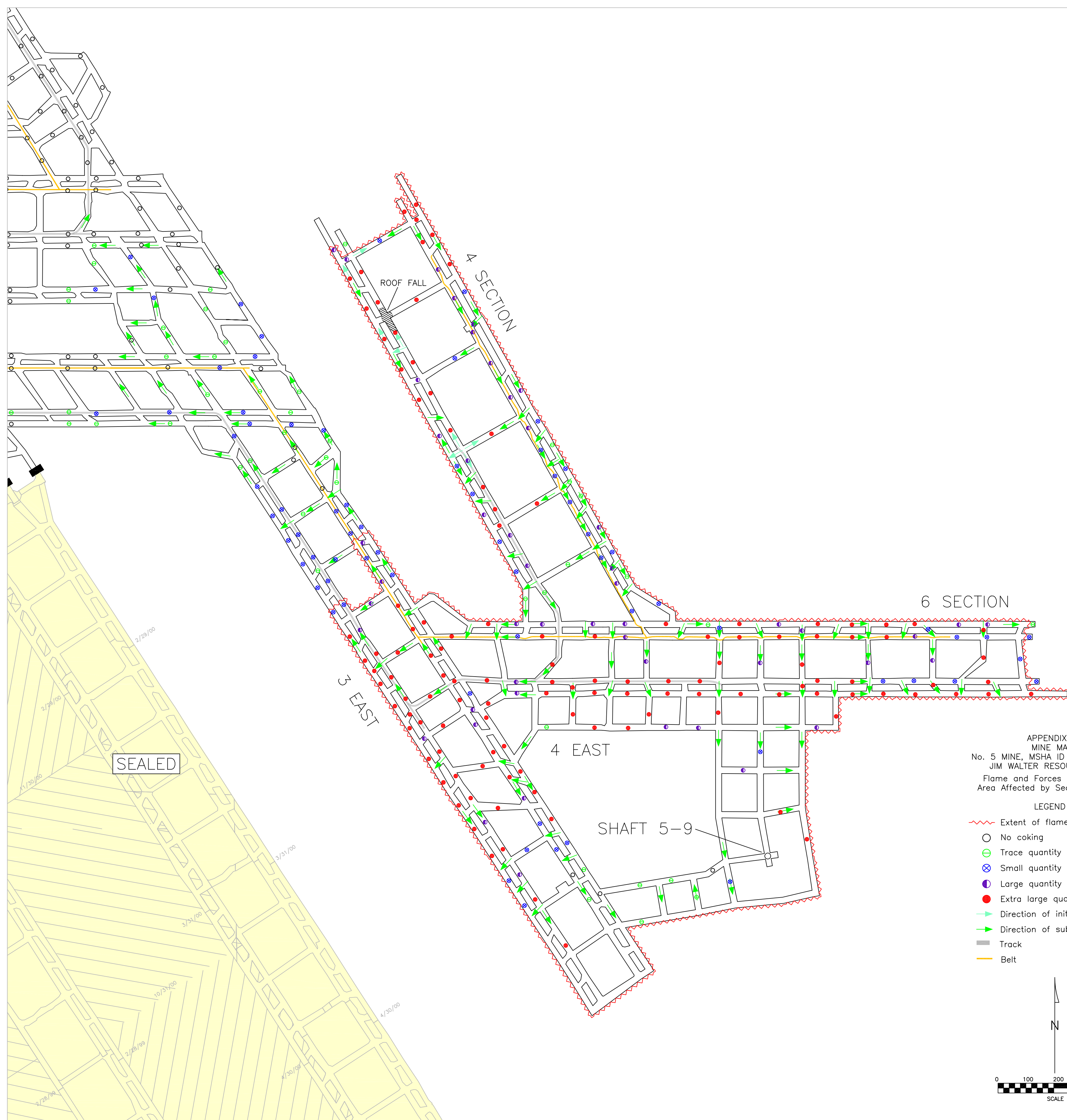

APPENDIX Q  
 MINE MAP  
 No. 5 MINE, MSHA ID No. 01-01322  
 JIM WALTER RESOURCES, Inc.  
 Flame and Forces in Immediate  
 Area Affected by Second Explosion

- LEGEND
- Extent of flame
  - No coking
  - Trace quantity of coking
  - Small quantity of coking
  - Large quantity of coking
  - Extra large quantity of coking
  - Direction of initial primary forces
  - Direction of subsequent primary forces
  - Track
  - Belt

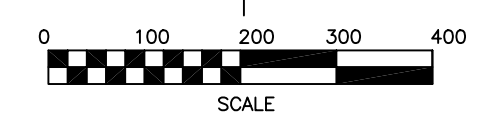
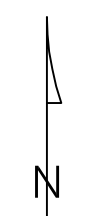

SEALED

ROOF FALL

4 SECTION

6 SECTION

3 EAST

4 EAST

SHAFT 5-9

2/29/00

2/29/00

11/30/00

3/31/00

3/31/00

10/31/00

4/30/00

4/30/00

2/26/99

2/26/99





SEALED

INTAKE SHAFT 5-8

CAR WASH SWITCH

LITTLE FAULT HILL

459 SWITCH

SEALED

SUB MAIN B

D PANEL SWITCH

E PANEL SWITCH

3 EAST HEADER

4 SECTION

6 SECTION

4 EAST

SHAFT 5-9

APPENDIX R  
MINE MAP  
No. 5 MINE, MSHA ID No. 01-01322  
JIM WALTER RESOURCES, Inc.  
Results of Testing on  
Mine Dust Samples

- LEGEND
- No coking
  - Trace quantity of coking
  - Small quantity of coking
  - Large quantity of coking
  - Extra large quantity of coking
  - 80.0 Percent incombustible, band sample
  - 80.0 Percent incombustible, roof/rib or other sample
  - Track
  - Belt
  - Seals constructed

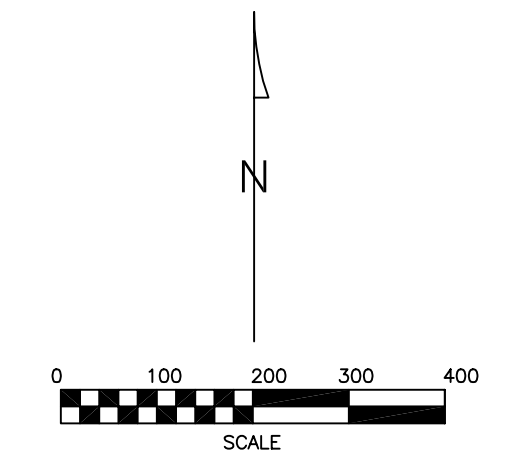

Note: Where band and other types of samples were collected in the same approximate area, only the result of testing of the band sample is shown. Where no band sample was collected, the result of testing of the sample type with the greatest perimeter is shown.



ADJACENT MINE

ADJACENT MINE

No. 1 EVALUATION POINT  
 8/12 28,070 dm 1.18  
 8/19 24,208 dm 1.45

No. 2 EVALUATION POINT  
 8/12 29,180 dm 1.28  
 8/19 24,800 dm 1.28

No. 3 EVALUATION POINT  
 8/12 24,000 dm 1.28  
 8/19 24,000 dm 1.28

No. 1 BLEEDER ENTRY (at main)  
 8/12 24,800 dm 1.28  
 8/19 20,800 dm 1.45

No. 2 BLEEDER ENTRY (at main)  
 8/12 21,900 dm 1.28  
 8/19 20,440 dm 1.45

No. 3 BLEEDER ENTRY (at main)  
 8/12 21,000 dm 1.08  
 8/19 20,100 dm 1.45

ROCK DUST BOREHOLE  
 8/12 20,800 dm 1.28  
 8/19 20,000 dm 1.28

ROCK DUST BOREHOLE  
 8/12 20,800 dm 1.28  
 8/19 20,000 dm 1.28

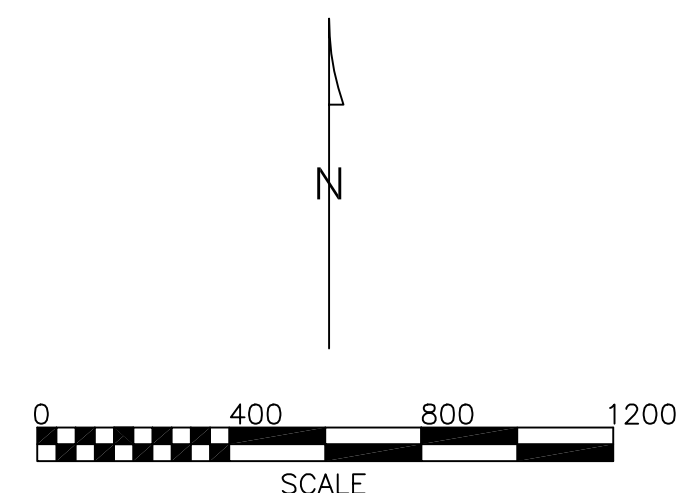

SEALED

2 EAST HEADER

1 EAST  
 SUMP-2 (2 EAST SUMP)  
 BIG FAULT HILL (ROCK TUNNEL)  
 FAN SHAFT 5-7

2 EAST

INTAKE SHAFT 5-8

LITTLE FAULT HILL  
 459 SWITCH  
 SUB MAIN B

2 EAST

D PANEL SWITCH  
 3 EAST TURN  
 E PANEL SWITCH

3 EAST HEADER  
 3 EAST  
 4 SECTION

SEALED

SEALED

SEALED

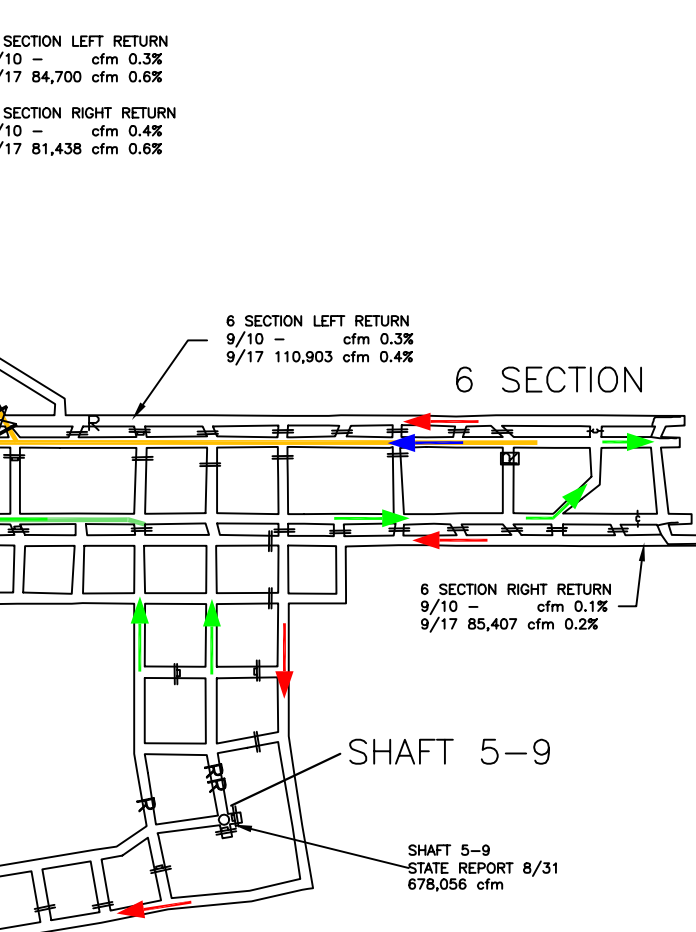
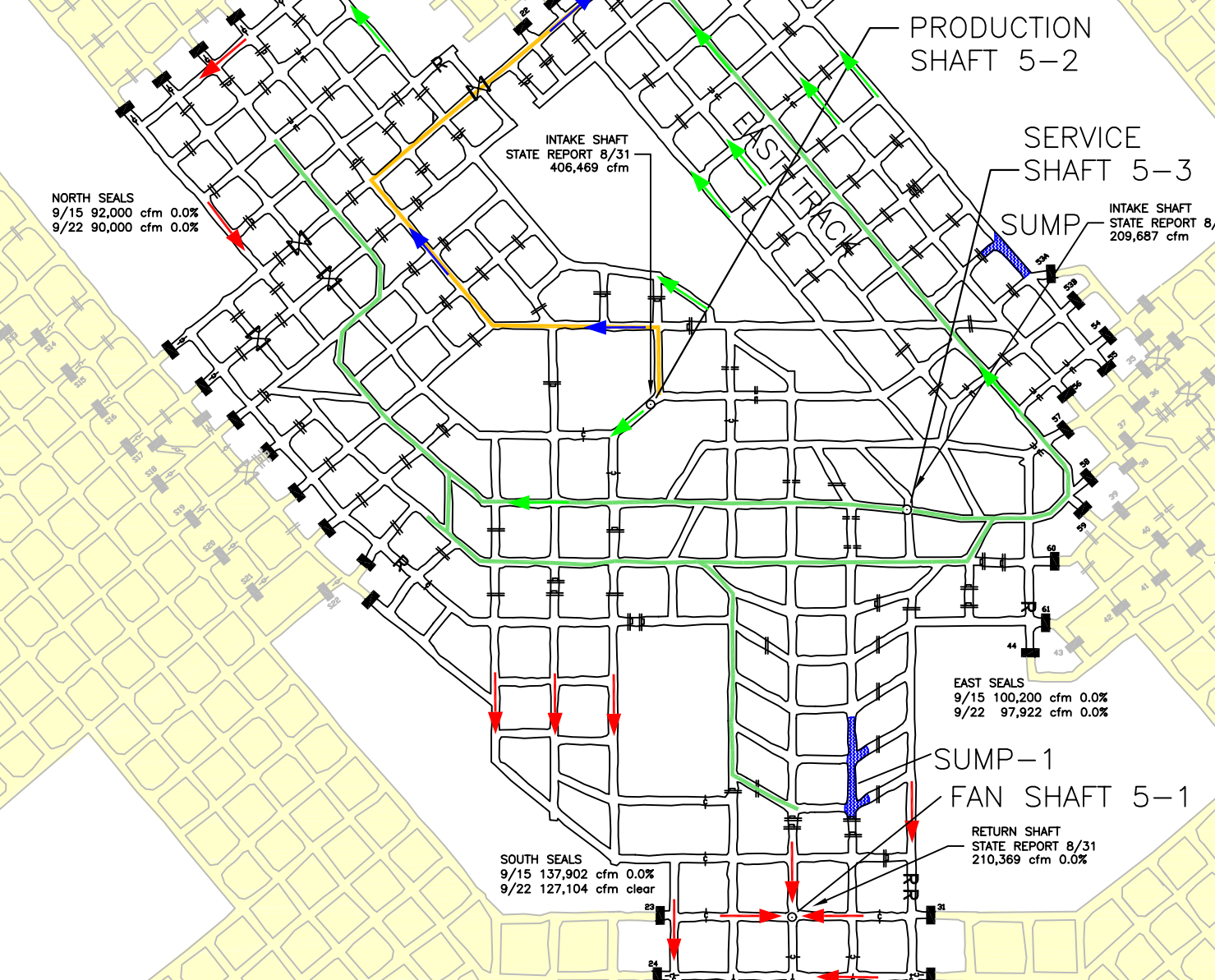

APPENDIX 5  
 MINE MAP  
 No. 5 MINE, MSHA ID No. 01-01322  
 JIM WALTER RESOURCES, Inc.  
 Mine Ventilation

- LEGEND
- Stopping
  - Stopping with mandoor
  - Check curtain
  - Overcast
  - R Regulator
  - Point feed
  - Intake airflow
  - Return airflow
  - Belt airflow
  - Track
  - Belt
  - Seals constructed
  - Seals proposed

Note: Unless otherwise noted, air quantity measurements and methane concentrations were obtained from the Weekly Examinations records.



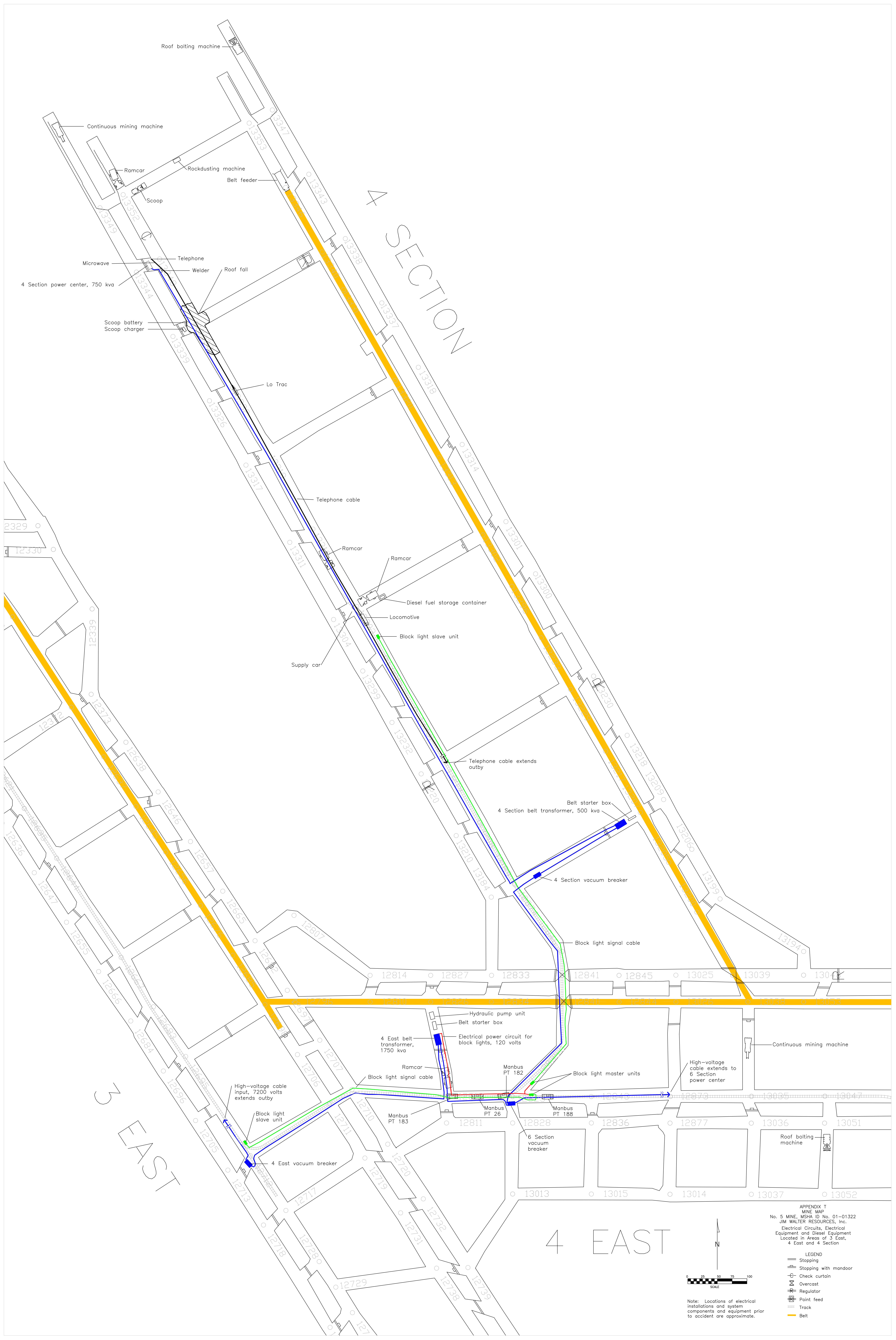

Roof bolting machine

Continuous mining machine

Ramcar

Rockdusting machine

Belt feeder

Scoop

Microwave

Telephone

Welder

Roof fall

4 Section power center, 750 kva

Scoop battery  
Scoop charger

Lo Trac

Telephone cable

4 SECTION

Ramcar

Ramcar

Diesel fuel storage container

Locomotive

Block light slave unit

Supply car

Telephone cable extends outby

Belt starter box  
4 Section belt transformer, 500 kva

4 Section vacuum breaker

Block light signal cable

Hydraulic pump unit

Belt starter box

4 East belt transformer, 1750 kva

Electrical power circuit for block lights, 120 volts

Ramcar

Manbus PT 182

Block light master units

High-voltage cable extends to 6 Section power center

Continuous mining machine

High-voltage cable input, 7200 volts extends outby

Block light slave unit

4 East vacuum breaker

Manbus PT 183

Manbus PT 26

Manbus PT 185

6 Section vacuum breaker

Roof bolting machine

3 EAST

4 EAST

APPENDIX 7  
MINE MAP  
No. 5 MINE, MSHA ID No. 01-01322  
JM WALTER RESOURCES, Inc.  
Electrical Circuits, Electrical  
Equipment and Diesel Equipment  
Located in Areas of 3 East,  
4 East and 4 Section

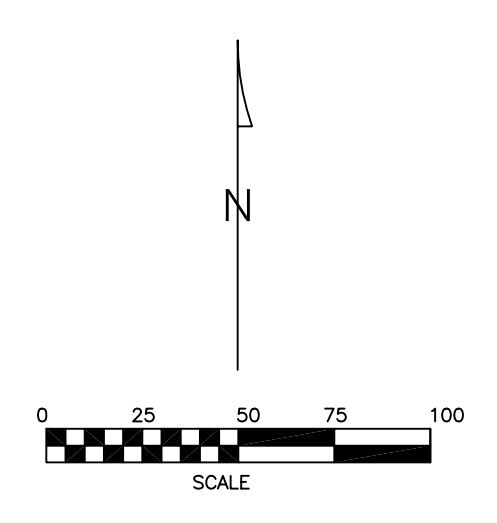

Note: Locations of electrical installations and system components and equipment prior to accident are approximate.





- LEGEND
- ≡ Stopping
  - ≡ Stopping with mandoor
  - ⊗ Check curtain
  - ⊗ Overcast
  - ⊗ Regulator
  - ⊗ Point feed
  - ≡ Track
  - ≡ Belt



APPENDIX U  
 MINE MAP  
 No. 5 MINE, MSHA ID No. 01-01322  
 JIM WALTER RESOURCES, Inc.

Roof Characteristics in  
 Affected Area

LEGEND



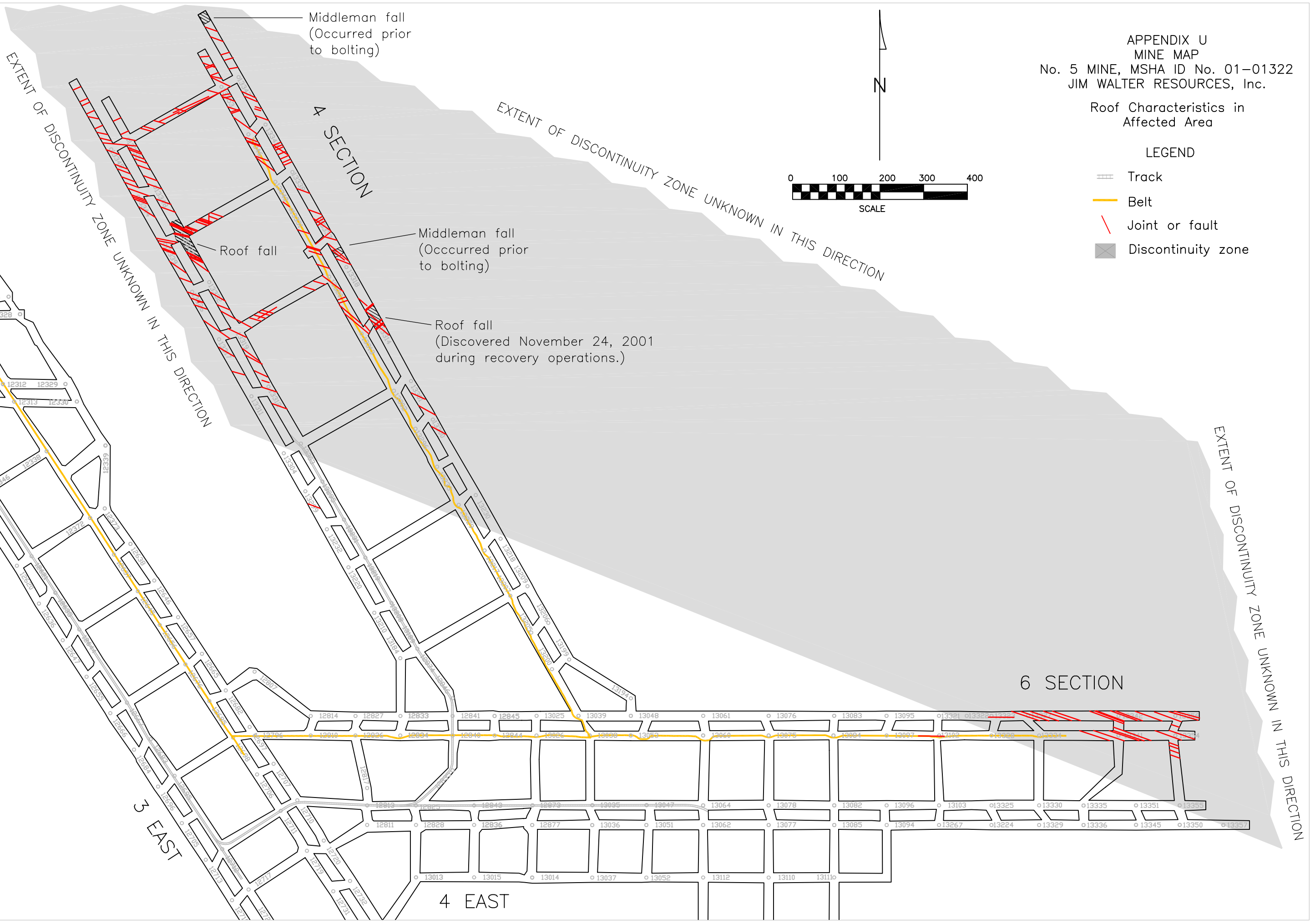
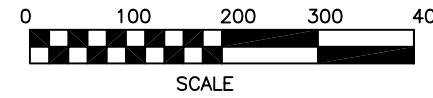
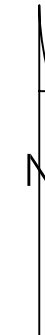



-  Track
-  Belt
-  Joint or fault
-  Discontinuity zone









APPENDIX V  
 COMPUTER SIMULATION MODEL  
 No. 5 MINE, ID No. 01-01322  
 JIM WALTER RESOURCES, Inc.  
 Ventilation of 4 Section

LEGEND

-  Stopping
-  Stopping with door
-  Check curtain
-  Overcast
-  Regulator
-  Point Feed
-  Track

-  1.2 INTAKE (1000 CFM)
-  1.2 RETURN (1000 CFM)
-  1.2 BELT (1000 CFM)
-  1.2 LEAKAGE (1000 CFM)

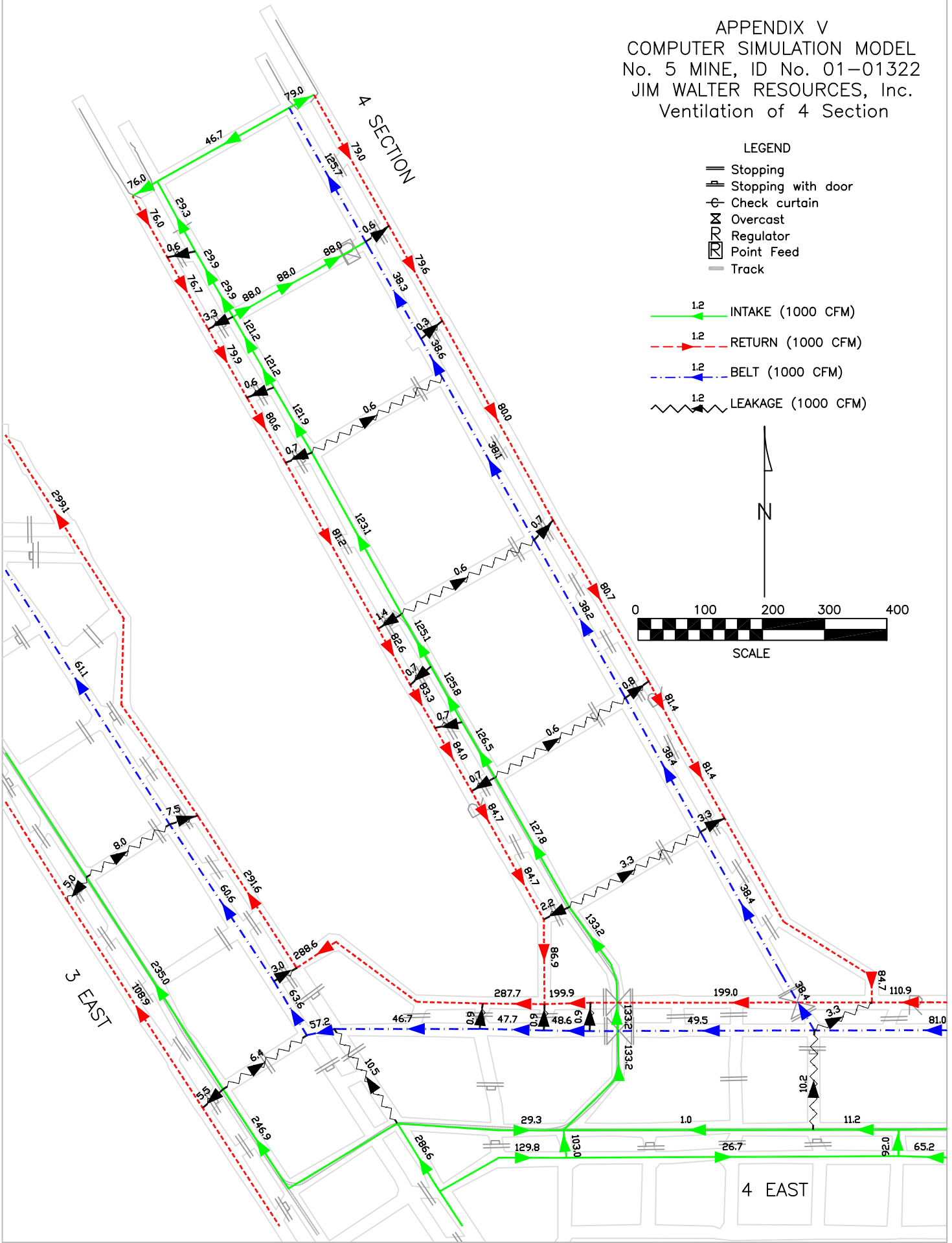
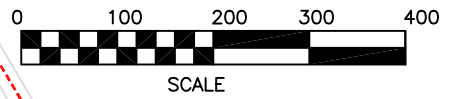
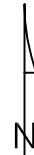

APPENDIX W  
 COMPUTER SIMULATION  
 No. 5 MINE, ID No. 01-01322  
 JIM WALTER RESOURCES, Inc.  
 Ventilation of 4 Section After  
 Roof Fall

LEGEND

- Stopping
- Stopping with door
- Check curtain
- Overcast
- Regulator
- Regulator
- Track

- 1.2 INTAKE (1000 CFM)
- 1.2 RETURN (1000 CFM)
- 0.5 PERCENT METHANE
- 1.2 BELT (1000 CFM)
- 1.2 LEAKAGE (1000 CFM)
- 0.5 METHANE (1000 CFM)

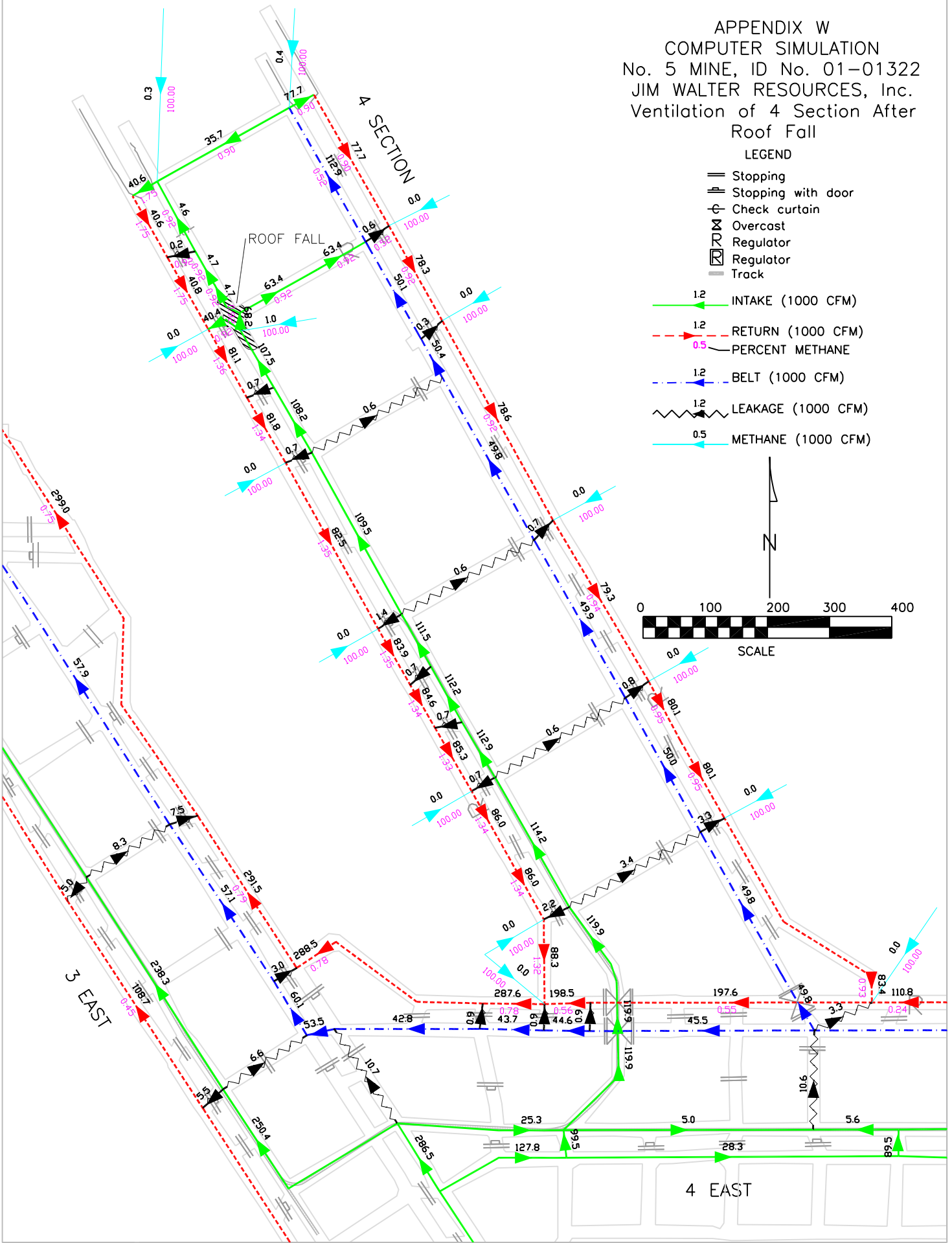
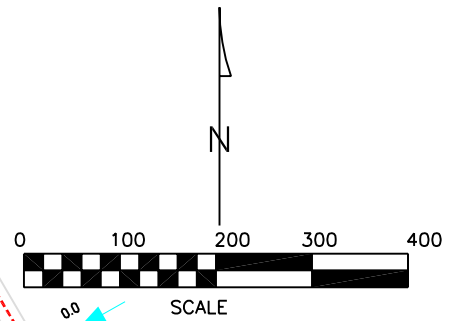

APPENDIX X  
 COMPUTER SIMULATION  
 No. 5 MINE, ID No. 01-01322  
 JIM WALTER RESOURCES, Inc.  
 Ventilation of 4 Section After  
 First Explosion

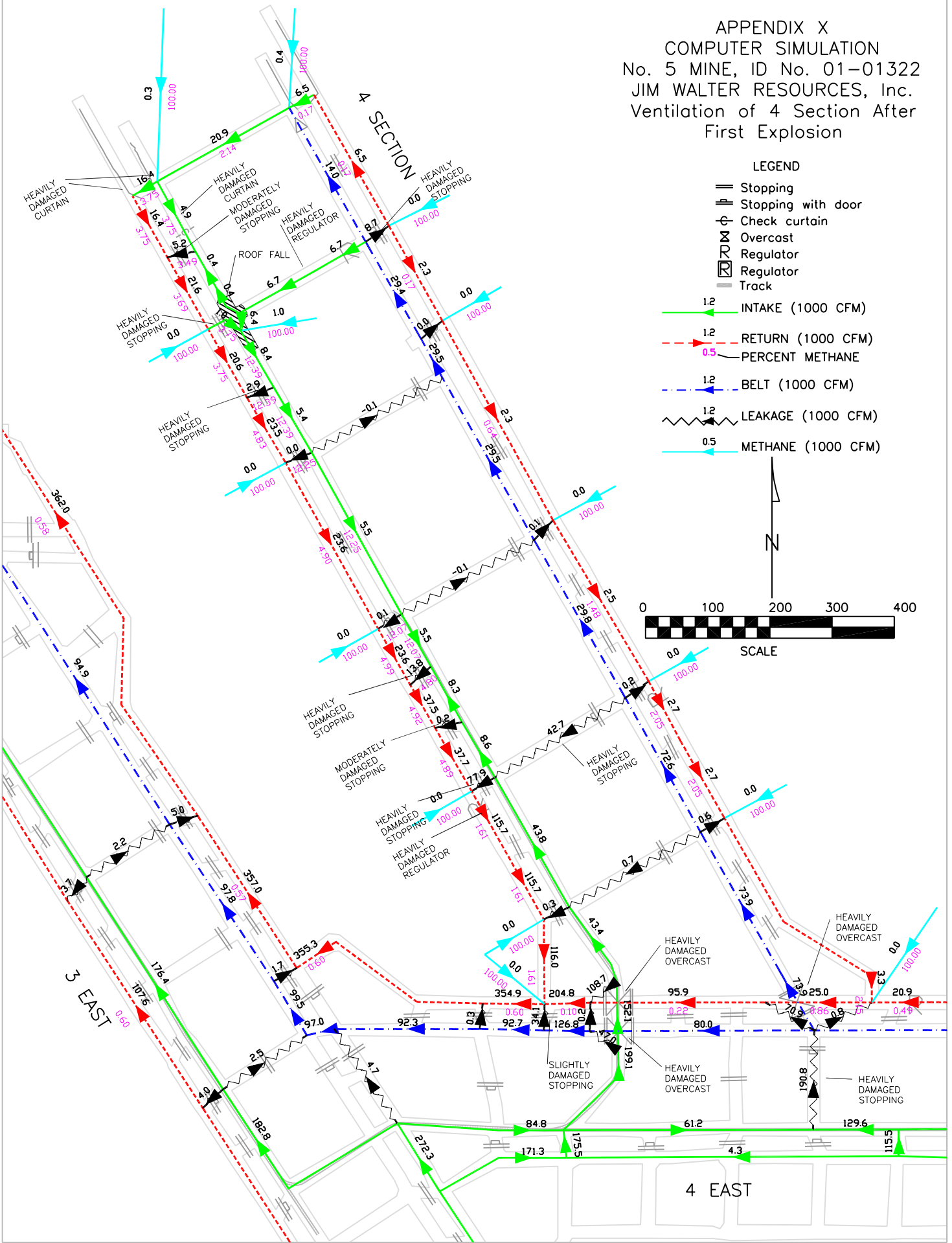

LEGEND

- INTAKE (1000 CFM)
- RETURN (1000 CFM)
- PERCENT METHANE
- BELT (1000 CFM)
- LEAKAGE (1000 CFM)
- METHANE (1000 CFM)
- Stopping
- Stopping with door
- Check curtain
- Overcast
- Regulator
- Regulator
- Track

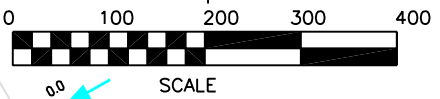



APPENDIX Y  
 COMPUTER SIMULATION  
 No. 5 MINE, ID No. 01-01322  
 JIM WALTER RESOURCES, Inc.  
 Ventilation of 4 Section After  
 Second Explosion

LEGEND

- Stopping
  - Stopping with door
  - Check curtain
  - Overcast
  - Regulator
  - Point Feed
  - Track
- 
- 1.2 INTAKE (1000 CFM)
  - 1.2 RETURN (1000 CFM)
  - 0.5 PERCENT METHANE
  - 1.2 BELT (1000 CFM)
  - 1.2 LEAKAGE (1000 CFM)
  - 0.5 METHANE (1000 CFM)

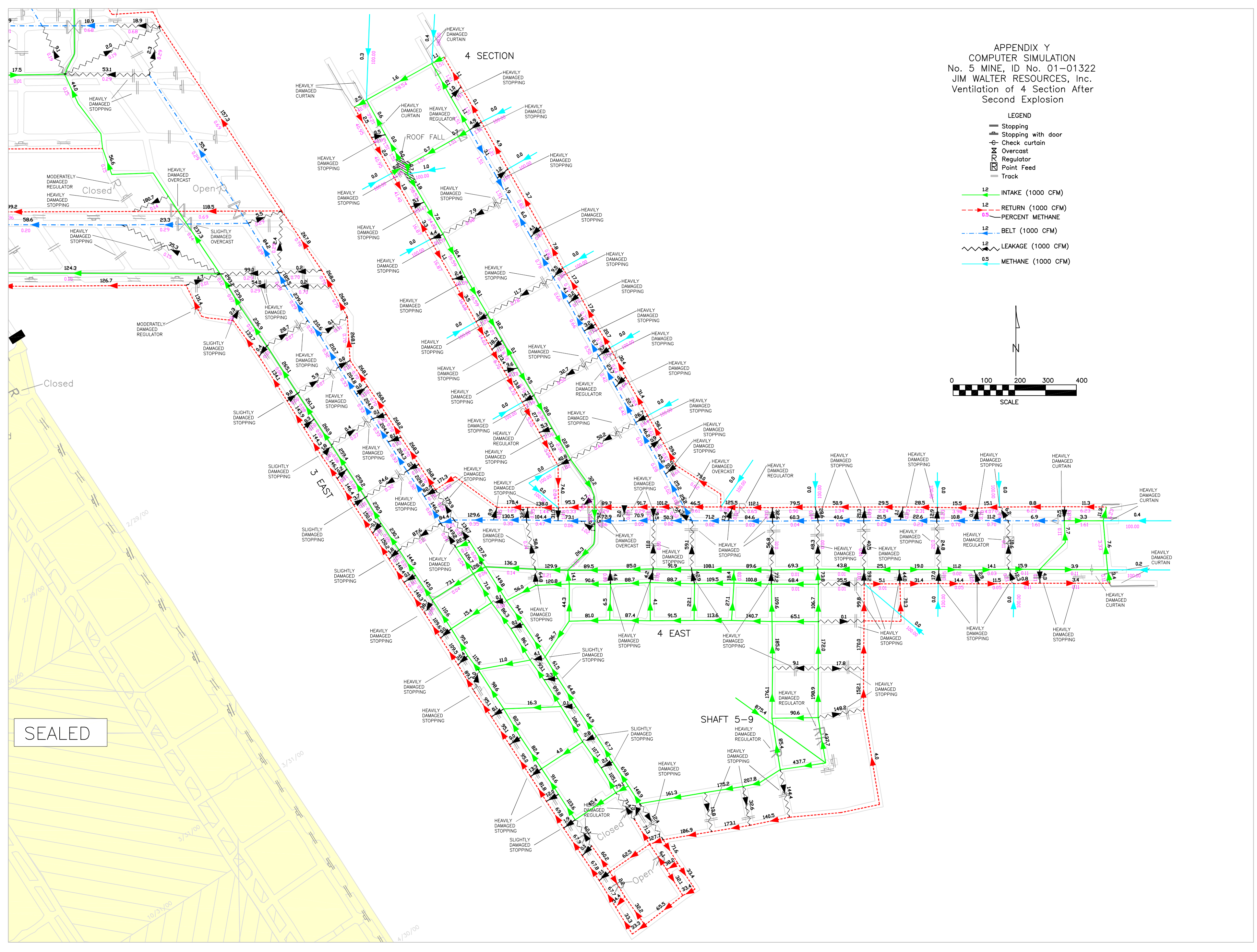
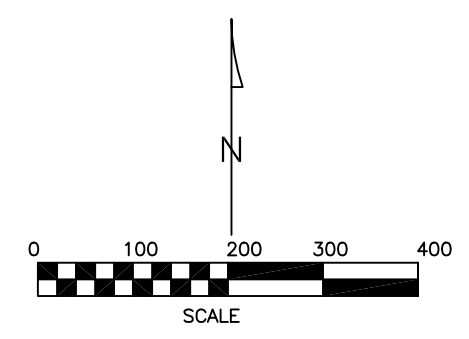

Appendix Z - Fan Shaft 5-7 Fan Pressure Recording Charts

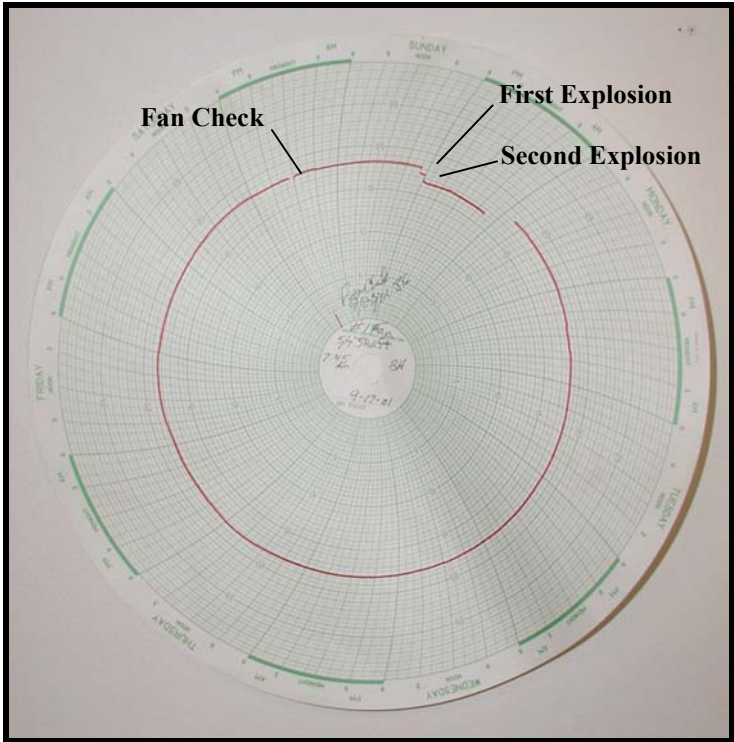

Fan Shaft 5-7 Fan No. 1 Pressure Recording Chart

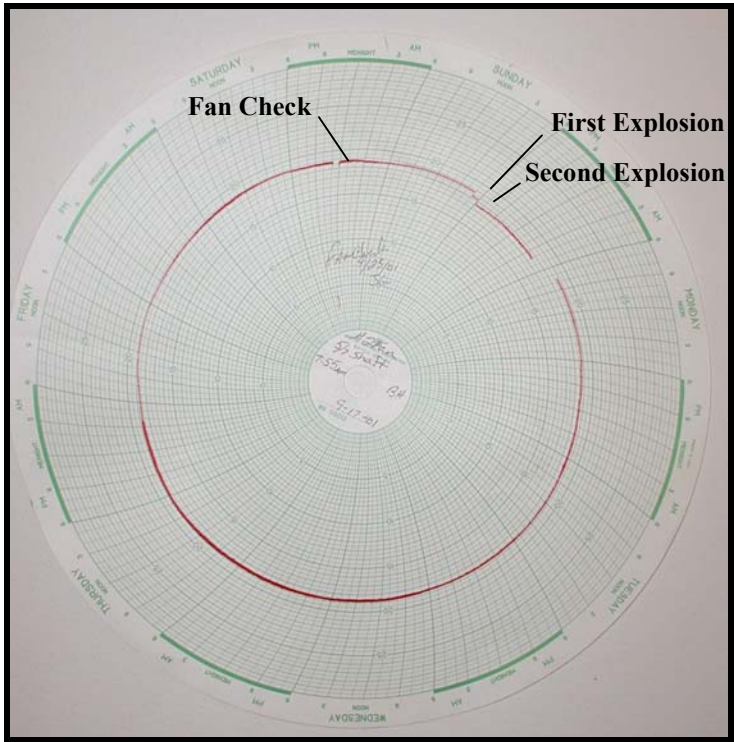

Fan Shaft 5-7 Fan No. 2 Pressure Recording Chart

## **Appendix AA - Mine Electrical Equipment and Circuits Not Located Within the Explosion Origin Zones**

4 East Vacuum Breaker Power Center, Line Power Manufacturing Company, Model VCB-1, Serial No. 6298. The 7200-volt circuit, which extended into 4 East and 4 Section originated at the 4 East vacuum breaker power center located at the mouth of 4 East near SS 12712. This power center contained visible disconnects and a vacuum circuit breaker that provided protection for the 4 East belt transformer, the 6 Section vacuum breaker, and the 4 Section vacuum breaker. The visible disconnects for the 4 East power center were in the closed position. The emergency stop switch (E-Stop) that de-energizes the high-voltage input from the vacuum breaker outby this power center was in the closed or non-trip position.

The 4 East vacuum breaker power center was damaged extensively by the second explosion. The explosion moved the power center from the No. 2 Entry side of the crosscut to the No. 1 Entry. The input high-voltage cable was pulled from the power center. The metallic frame and lids were bent. The overcurrent, short circuit and ground fault protective relay flag indicators were in an activated position.

The 4 East vacuum breaker power center did not provide the ignition source for the first or second explosion. This conclusion was based on the location of the power center.

4 East Belt Transformer Power Center, Line Power Manufacturing Company, Model 1750 PC, Serial No. R2078. This power center was located on 4 East Mains between the mouth of 4 East and the mouth of 4 Section near SS 12826. The belt transformer received 7200-volt power from the 4 East vacuum breaker. The high-voltage power was continued by way of a feed-through to the 6 Section vacuum breaker power center. The secondary side of the belt transformer provided three-phase 1040-volts to the 4 East belt drive. Single-phase 120-volt power was provided to the belt control circuitry and the block light system used in the track entry for 4 East Mains and 4 Section. The visible disconnects for the transformer were in the closed position. The E-Stop that de-energizes the outby 4 East vacuum breaker was in the non-trip position. The circuit breaker to the belt drive motor was in the center or tripped position. The 20-ampere circuit breaker for the block light system used on 4 East Mains and 4 Section was in the closed position.

This power center experienced some heat and dust damage from the explosion but little other damage. The 4 East belt transformer power center did not provide the ignition source for the first or second explosion. This conclusion was based on the location of the power center.

6 Section Vacuum Breaker Power Center, Line Power Manufacturing Company, Model VCB-2, Serial No. 6306. This power center was located just outby the mouth of 4 Section near SS 12825. The vacuum breaker received high-voltage power from the feed-through on 4 East belt transformer and continued the high-voltage power by way of feed-through to the 4 Section vacuum breaker power center. The output of the vacuum circuit



breaker provided power to the 6 Section power center. The visible disconnects of the power center were in the closed position. The E-Stop that opens the 4 East vacuum breaker was in the closed or non-trip position.

Forces from the second explosion blew the power center through a stopping into the next entry damaging the lids and frame. Both the input and the output high-voltage cables were pulled from the power center. The overcurrent, short circuit and ground fault protective relay flag indicators were in a non-activated position.

The 6 Section vacuum breaker power center did not provide the ignition source for the first or second explosion. This conclusion was based on the location of the power center.

4 Section Vacuum Breaker Power Center, Line Power Manufacturing Company, Model VCB-1, Serial No. R2879. This power center was located near the mouth of 4 Section in the crosscut between No. 2 and No. 3 Entries adjacent to SS 13189. The power center was positioned in the No. 2 Entry side of the crosscut stopping. The vacuum breaker received high-voltage power from the feed-through on the 6 Section vacuum breaker power center. It contained visible disconnects and a vacuum breaker that provided protection to the 4 Section belt transformer power center and the 4 Section power center. The visible disconnects were in the disconnect or open position. The E-Stop that de-energizes the high-voltage input by opening the outby 4 East vacuum breaker was in the open or trip position.

This power center received extensive damage from the second explosion. The explosive forces damaged the frame of the power center, blew the lids off, and pulled the output high-voltage cable from its connections.

The 4 Section vacuum breaker power center did not provide the ignition source for the first or second explosion. This conclusion was based on the location of the power center.

4 Section Belt Transformer Power Center, Line Power Manufacturing Company, Model 500, Serial No. 6316. This power center was located in the same crosscut as the 4 Section vacuum breaker power center but in the No. 3 Entry side of the stopping between the No. 2 and the No. 3 Entries. It received high-voltage power from the output of the 4 Section vacuum breaker. The secondary side of the transformer provided three-phase 480-volts to the 4 Section belt drive. Single-phase 120-volts was provided for the belt drive control circuitry. The visible disconnects for the power center were in the closed position. The E-Stop that de-energizes the 4 Section vacuum breaker was in the open or trip position. The 480-volt output circuit breaker to the belt drive motor was in the center or tripped position.

The power center was severely damaged by the second explosion. The power center frame was bent, lids blown off, and high and low-voltage cables pulled from their connections.

The 4 Section belt transformer power center did not provide the ignition source for the first or second explosion. This conclusion was based on the location of the power center.

4 Section Power Center, Line Power Manufacturing, Model 750 PC, Serial No. 4919.

The section power center was located in the crosscut between the No. 1 and No. 2 Entries near SS 13348. Power was provided by a 4/0 high-voltage cable that exited the feed-through on the 4 Section belt transformer power center. The cable traveled approximately 1400 feet along the left side of the No. 2 Entry to the section power center. The visible disconnects for the power center were in the closed position. The E-Stop that de-energizes the high-voltage input from the 4 Section vacuum breaker was in the non-trip position. The 4 Section power center contained a 750 kva dual wound transformer that reduced the voltage to 1040 and 600-volts for utilization by the section equipment. Circuit breakers and receptacles provide the required protection for 12 three-phase circuit outlets. All these circuit breaker handles were in the center trip position. Six of these circuits were not used. Single-phase 120-volt power was also provided at the power center with three duplex outlets. Each of the outlets was protected by a single-phase circuit breaker that was in the closed position.

The power center was examined for any signs of arcing or shorting. No signs were found. The power center supplied the following three-phase equipment with electricity:

1. Joy Model 12CM12-10BX Continuous Mining Machine (1040-volts)
2. J.H. Fletcher Model RR-II-15-B,CF Roof Bolting Machine (600-volts)
3. A.L. Lee Corporation Rockduster, Serial No. 98E-6890 (600-volts)
4. Stamler Belt Feeder, Model BF-14 (600-volts)
5. Miller, Model 250 DialArc, Welder (600-volts)
6. Douglas Manufacturing Company Battery Charger (600-volts)

The power center supplied the following single-phase equipment with electricity:

1. Mercury vapor light
2. Microwave oven
3. 14- inch chopsaw

The section power center received minor damage from the accident. A top cover was blown off the power center and lay nearby against a picnic table in the No. 2 Entry side of the crosscut. This action pulled the 120-volt mercury vapor light plug from its receptacle. The plug and cord were pulled apart. The microwave oven and chopsaw, located on top of the power center, were pulled from their receptacles and were laying on the mine floor in the No. 1 Entry side of the power center. The receptacles for the roof bolting machine and belt feeder were pulled from the power center and were laying in the No. 2 Entry.

The 4 Section power center did not provide the ignition source for the first or second explosion. This conclusion was based on the examination and the location of the power center.



S&S Corporation Battery Powered Scoop Tractor, Model 488, Approval No. 2G-2831-3, Serial No. 488-1139. The permissible scoop tractor was located in the last open crosscut between No. 1 and No. 2 Entries near SS 13352. The battery end of the tractor was positioned toward the No. 1 Entry. The pump motor switch and the tram direction switch were in the off position. The position of these switches and testimony indicated the machine was not running. The main circuit breaker was in the tripped position. The panic bar was activated either by the last operator of the tractor or by the explosion that knocked the panic bar out of its mounting dowel and allowed it to rest on the emergency stop button on the controller. The light switch was in the on position in the reverse (battery end) direction. It is not likely an operator would have left the lights burning after operation of the tractor. If the operator engaged the panic bar, this action would have turned off all power to the lights. Also, it is possible the switch was knocked into the on position during the explosion because the light switch was located on top of the main controller panel in the operator's deck and the position of the switch was in the same direction debris from the explosion was propelled. The parking brake lever was in the center-up position. This indicated the parking brake was set. The scoop tractor was not being operated at the time of the accident.

The 128-volt battery for the tractor was made by Douglas Battery Manufacturing Company (Certification No. 2250-3). The battery assembly was laying upside down approximately 10 feet from the rear of the machine toward the No. 1 Entry. Statements and physical evidence indicated the tractor was moved toward the No. 1 Entry by forces of the second explosion and the battery was rolled from its compartment when the tractor came to a sudden stop. All the electrolyte had drained from the cells. Voltage measurements and tests made on the battery indicated the battery had no electrical energy and was effectively discharged because of the electrolyte drainage. There were no cells that had been jumpered out in the battery assembly. No indications were found of arcing or shorting on the receptacles, leads or the battery cells.

The scoop tractor and its batteries did not provide the ignition source for the first or second explosion. This conclusion was based on the permissibility examination, operational mode, and location of the tractor.

Joy Continuous Mining Machine, Model 12CM12-10BX, Approval No. 2G-3996A-0, Serial No. JM5166. The remotely controlled continuous mining machine was located in the face of the No. 1 Entry. The 1040-volt mining machine and trailing cable was protected by a 600-ampere circuit breaker on the section power center. The circuit breaker handle was in the center-tripped position. The receptacle for the 2/0 shielded trailing cable was plugged into the section power center. The main circuit breaker, traction motor breaker, and control breaker located onboard the machine were in the on position. The breaker for the machine's lights was in the off position. The remote controller, a Matrix Limited Model 205-376 unit, was lying on top of the machine in front of the operator's deck. The emergency stop mushroom switch located on top of the remote control unit was in the off position. The off position should cause the main circuit breaker to trip. Because the main circuit breaker is a shunt trip breaker that requires

electrical power to trip, the operator may have removed his battery source from the remote controller before he pushed the E- Stop button. This unit was tested during the investigation and the E- Stop button tripped the main circuit breaker every time it was pushed. The Appalachian Methane Monitor, Part No. 7678 was tested during the investigation. The continuous mining machine was energized and a known mixture of 2.5 per cent methane was applied at the sensor. The monitor gave a warning at 1.0 per cent and de-energized the machine at 2.0 percent.

The machine experienced little or no damage from the explosions. The trailing cable suffered damage where it lay in the last open crosscut by debris from the second explosion. No signs of electrical arcing were observed on the machine's trailing cable. Nail and Mobley moved the machine from the mouth of No. 1 Entry inby to the face of No. 1 Entry prior to the explosion. After Nail and Mobley completed the task, it is not known if they opened the circuit breaker on the power center for the continuous mining machine before they traveled to 6 Section. The machine was not being operated at the time of the accident.

The 2/0 trailing cable for the continuous mining machine may have been energized with 1040 volts. The cable was of a shielded type that provides an additional barrier besides the insulation to the energized conductors. The cable was in excellent condition except in the area of the last open crosscut where debris from the second explosion damaged the cable. Signs of arcing were not observed.

The continuous mining machine and its trailing cable did not provide the ignition source for the first or second explosion. This conclusion was based on the permissibility examination, operational state, and location of the continuous mining machine and the physical examination and location of the trailing cable.

J.H. Fletcher Roof Bolting Machine, Model RR-II-15-B, CF, Approval No. 2G-3715A-1, Serial No. 2001318. The machine was located in the face area of the No. 4 Entry. The 600-volt machine and its trailing cable were protected by a 225-ampere circuit breaker on the section power center. The circuit breaker handle was in the center-tripped position. The No. 4 trailing cable traveled from the section power center into the No. 2 Entry, down the last open crosscut to the roof bolting machine. The receptacle for the trailing cable was pulled from the power center by forces from the second explosion and was lying in the No. 2 Entry approximately 8 feet from the power center. The trailing cable was pulled apart in the last open crosscut between the No. 2 and No. 3 Entries. The trailing cable was pulled from the cable reel strain clamp and unspooled from the cable reel. No signs of electrical arcing were observed where the cable reel was pulled from the machine, where the cable was pulled apart or at the other damaged areas on the cable. The main circuit breaker onboard the roof bolting machine was in the off position. The machine had received damage from the second explosion. Two of the headlights were found lying on the floor just outby the machine and the other two headlights on the machine were broken. Several metal coverings for the machine had been bent and damaged. The roof bolting machine was not being operated at the time of the accident nor had it been operated during the shift of the accident.

The roof bolting machine and its trailing cable did not provide the ignition source for the first or second explosion. This conclusion was based on the permissibility examination and location of the bolting machine, the physical examination and location of the trailing cable, and that neither the machine nor its cable was energized.

A.L. Lee Corporation Rockduster, Approval No. 2G-2368A-3, Serial No. 98E-6890. The rockdusting machine was located in the crosscut between the No. 2 and No. 3 Entries. The 600-volt machine and its trailing cable were protected by a 180-ampere circuit breaker on the power center. The circuit breaker handle was in the center-tripped position. The receptacle for the No. 10 trailing cable was plugged into the section power center. The trailing cable was pulled apart in the last open crosscut near the rockdusting machine. No signs of electrical arcing were observed where the cable was pulled apart. The onboard circuit breaker for the machine was in the off position. The machine received some structural damage from the explosion. The machine was not being operated at the time of the accident.

The rockdusting machine and its trailing cable did not provide the ignition source for the first or second explosion. This conclusion was based on the permissibility examination and location of the dusting machine, physical examination and location of the trailing cable, and that neither the machine nor its cable was energized.

Miller Welding Machine, Model 250 DialArc. The welding machine was located in the No. 2 Entry along the left rib just outby the power center. The 600-volt machine and its trailing machine were protected by a 180-ampere circuit breaker on the section power center. The circuit breaker handle was in the center-tripped position. The receptacle for the No. 6 trailing cable was plugged into the section power center. The trailing cable was coiled along the left rib outby the power center to the welding machine. Much of the cable was under rib sloughage. There was little or no damage to the welding machine and cable from the accident. The welding machine was not being used at the time of the accident nor had it been operated during the shift of the accident.

The welding machine and its trailing cable did not provide the ignition source for the first or second explosion. This conclusion was based on the examination and location of the machine and its trailing cable, and that neither the machine nor cable was energized.

Stamler Belt Feeder, Model BF-14. The belt feeder was a non-permissible type located in the No. 3 Entry outby SS 13353. The 600-volt feeder and its trailing cable were protected by a 225-ampere circuit breaker on the section power center. The circuit breaker handle was in the center trip position. The 2/0 trailing cable traveled from the power center into the No. 2 Entry, through the last open crosscut to the belt feeder. The receptacle for the trailing cable was pulled from the power center by forces from the second explosion. The receptacle was located approximately 10 feet from the power center in the No. 2 Entry. The trailing cable was pulled apart in the last open crosscut between the No. 2 and No. 3 Entries. The cable was damaged in several locations. Signs of arcing were not observed at these damaged locations. The onboard circuit

breaker for the belt feeder was in the on position. Testimony indicated the belt feeder was not energized at the power center or was it operated during the shift before the accident.

The belt feeder and its trailing cable did not provide the ignition source for the first or second explosion. This conclusion was based on the examination of the feeder and its trailing cable, their locations, and that neither the machine nor its cable was energized.

Single-phase Equipment connected to the power center:

- a. Mercury Vapor Light, 180 watt (no legible markings). The light was mounted over the power center. The light was plugged into a 120-volt duplex outlet mounted on the No. 1 Entry side of the power center. The circuit was protected by a 20-ampere single-phase circuit breaker that was in the closed position. Forces from the second explosion blew a lid off the power center, which disconnected the light plug from the outlet and pulled the plug from the light cord. No signs of arcing were observed where the plug and cable were pulled apart. The light received little physical damage from forces of the accident but did have heat and soot damage.

The mercury vapor light was burning at the time of the first explosion. The light burning will not provide a sufficient amount of heat to ignite methane or coal dust. The bulb filament could produce an arc if it should open. The filament was not open.

The mercury vapor light did not provide the ignition source for the first or second explosion. This conclusion was based on the examination of the light and its location.

- b. Microwave Oven, (no legible markings). The oven was laying in the No. 1 Entry near the power center after the accident. The oven was probably located on the power center before the accident. The oven was plugged into a 120-volt duplex outlet mounted on the No. 1 Entry side of the power center. The circuit was protected by a 20-ampere single-phase circuit breaker that was in the closed position. The plug was pulled from the receptacle. The oven received moderate damage from the forces of the accident.

The microwave oven would not have been operating at the time of the accident but was most likely plugged into an energized receptacle.

The microwave oven did not provide the ignition source for the first or second explosion. This conclusion was based on the examination of the oven, its operational state, and location.

- c. Chopsaw, 14-inch, (no legible markings). The chopsaw was lying near the power center on the No. 1 Entry side. The chopsaw was probably located on the power

center before the accident. The chapsaw was plugged into a 120-volt duplex outlet mounted on the No. 1 Entry side of the power center. The circuit was protected by a 20-ampere single-phase circuit breaker that was in the closed position. The plug was pulled from the receptacle. The saw received moderate damage from the forces of the accident.

The chapsaw would not have been operating at the time of the accident but was most likely plugged into an energized receptacle.

The chapsaw did not provide the ignition source for the first or second explosion. This conclusion was based on the examination of the saw, its operational state, and location.

Telephone, Gai-Tronics, Model 491-204, Approval No. 9B-43-04, Serial No. 134990.

The mine phone was located in the No. 2 Entry near the power center. The mine rescue team had removed the phone battery. The phone had little damage from the accident. The telephone operated properly when tested after a battery was installed. The phone was examined to determine if it complied with the MSHA approval drawings. Only minor discrepancies were found between the approval documentation and the phone. The interface cabinet that separates the permissible mine phone system and the public system was examined. Only minor discrepancies were found between the MSHA approval documentation and the interface card for the 4 Section address. Signs of overvoltage or short circuits were not observed on the interface card.

The most electrical energy the phone or its cable can experience during operation is during paging. Testimony did not indicate that any paging occurred to 4 Section until after the first explosion. After the first explosion, 4 Section was paged numerous times. The telephone could only be paged from the phone located in the Mine Wide Monitoring room on the surface and another phone at the bottom of the Service Shaft. Voltage measurements were made with an oscilloscope to determine the maximum voltage that occurred on the phone system when paging occurred. The maximum voltage measured on the phone system was 19.53 volts when the phone was hung up after paging. The impedance of the phone cable from the surface to 4 Section was measured and calculated. A spark test was conducted to simulate a worst case scenario for the phone system. A spark was repeated nearly 2000 times using the maximum voltage measured on the phone system, an ideal mixture of methane, and the impedance of the cable. The testing indicated that there was not sufficient energy from paging to ignite methane on this phone system.

The telephone or its cable did not provide the ignition source for the first or second explosion. This conclusion was based on the examination and testing of the phone system, phone and cable. The system did not have sufficient energy to ignite methane.

Belt Control Cable, Type SO, Size No. 16. The belt control cable was supported on insulators in the No. 3 Entry of No. 4 Section. The cable provided 120-volt control power to the 4 Section belt conveyor system. The circuit was protected by a 20-ampere

circuit breaker located on the 4 Section belt transformer that was in the closed position. The cable was damaged severely by the second explosion. The cable was pulled apart in several locations.

The belt control cable did not provide the ignition source for the first or second explosion based on its location and that it was not energized at the time of the second explosion.

Fire Detection Cable and Sensors. The point type heat sensors were supported on insulators in the No. 3 Belt Entry. The cable and sensors were severely damaged from forces of the second explosion.

Ecko Fire Protection manufactured the point type heat sensors. The fire detection for each belt flight was connected to a multifunction card and consisted of Ecko BK-250-5 assemblies and terminating diodes. Each assembly consisted of five sensors connected to a 250-foot cable. The monitoring system provided 24-volt direct current to the fire detection sensors.

The fire detection cable and sensors did not provide the ignition source for the first or second explosion because of their location.

Mine Wide Monitoring System The cable for the system was supported on insulators in the No. 3 Belt Entry of 4 Section. This cable received extensive damage from the second explosion. The CO sensor for 4 Section was near the belt tailpiece. This CO sensor was not operational at the time of the accident. The belt was not being operated at the time of the accident.

The monitoring system in place at the JWR No. 5 Mine was a proprietary system, designed and installed by JWR. The software, which resides on three computers on the surface, was written by JWR. Of these computers, one called the MCP, gathers data from underground and aboveground, send signals, and provides printouts. The others are for editing and graphics. The computer used for editing also houses the main database.

The CO sensors were made by Conspec Controls, which included integral visual/audible alarms. The sensors use 24 volts dc, except when in areas where permissibility is required, where they use 15 volts dc.

The trunk cable, which is ultimately connected to the MCP, extends underground and is fiber optic. These multiconductor trunk cables can connect to various outstations and repeaters underground. The outstations are designed to use multifunction cards that allow 16 digital inputs, 8 digital outputs, and 8 analog inputs. The system is designed to scan the analog and digital inputs sequentially; the complete sequence at the JWR No. 5 Mine took 2.5 to 2.8 seconds to scan all inputs.

The Mine Wide Monitoring System did not provide the ignition source for the first or second explosion because of its location.

Jeffrey Diesel Ramcar, Model 4110, Serial No. 38746. The permissible rubber-tired Ramcar was located inby the last open crosscut of No. 2 Entry near SS 13352. A water-cooled MWM Model D916-6, 94 horsepower, in-line six cylinder engine with an automatic transmission powered the Ramcar.

The transmission was in neutral with the emergency park brake set. The water scrubber, an engine safety component that provides for exhaust gas cooling and flame arresting protection, contained a sufficient amount of water to function properly. The engine coolant in the radiator was adequate. The fuel tank contained fuel.

The machine received moderate damage from the accident. Several engine compartment covers were blown from the machine exposing the engine. The machine was not being operated at the time of the accident. The examination of the machine revealed it was in permissible condition.

The diesel Ramcar did not provide the ignition source for the first or second explosion. This conclusion was based on the permissibility examination, state of operation and location of the machine.

CLA Lo Trac Diesel Forklift, Model 5640N. The non-permissible rubber tired Lo Trac was located in the No. 2 Entry near SS 13332. This location is three crosscuts outby the last open crosscut of 4 Section. The Lo Trac was powered by an oil/air cooled Deutz Model F3L1011, 44 horsepower, in-line three cylinder engine with a hydrostatic transmission.

The ignition switch was in the off position. The headlight switches were in the off position. The park brake was set to the on position. The fuel tank contained fuel.

The machine received little damage from the accident. The machine was not being operated at the time of the accident.

The diesel Lo Trac did not provide the ignition source for the first or second explosion. This conclusion was based on the examination, state of operation and location of the machine.

# Appendix BB - 4 Section and 4 East High-Voltage Electrical Schematic Diagram

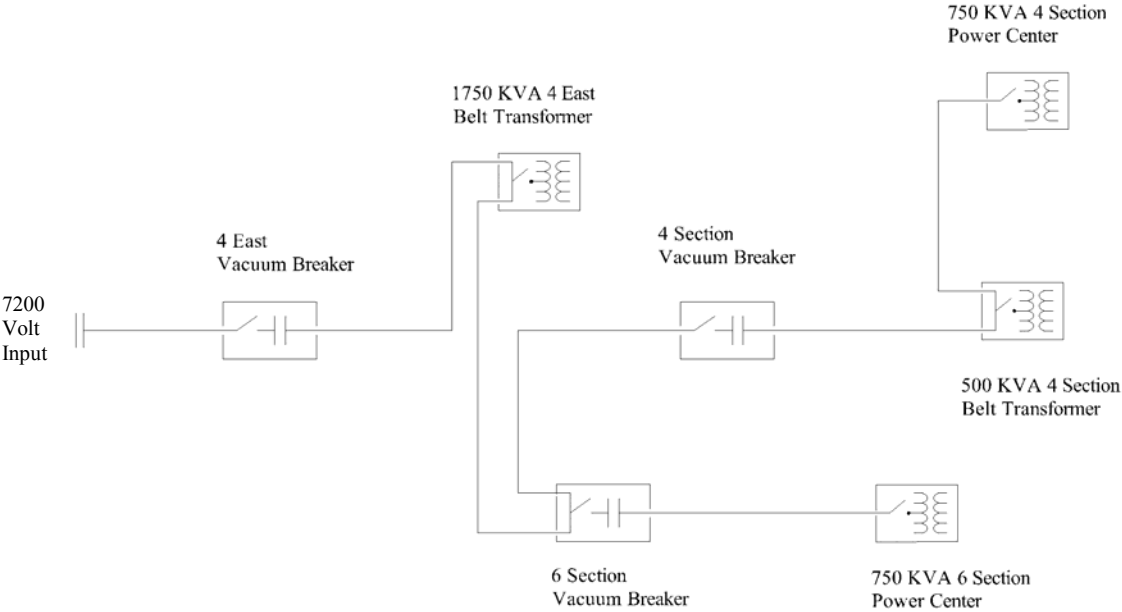



# Appendix CC - 4 Section Block Light Electrical Circuit Diagram

## Master Block Light Box

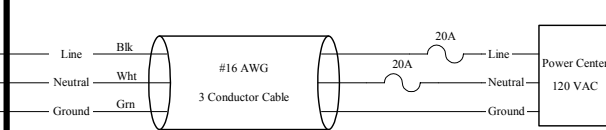
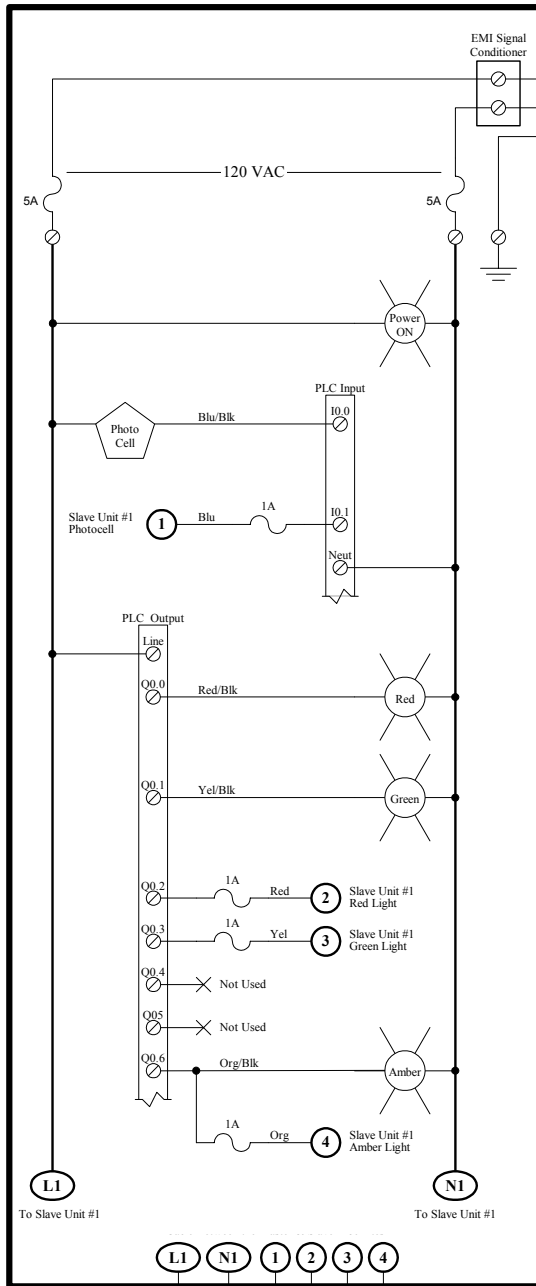

## Slave Unit Block Light Box

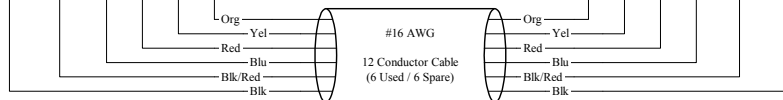
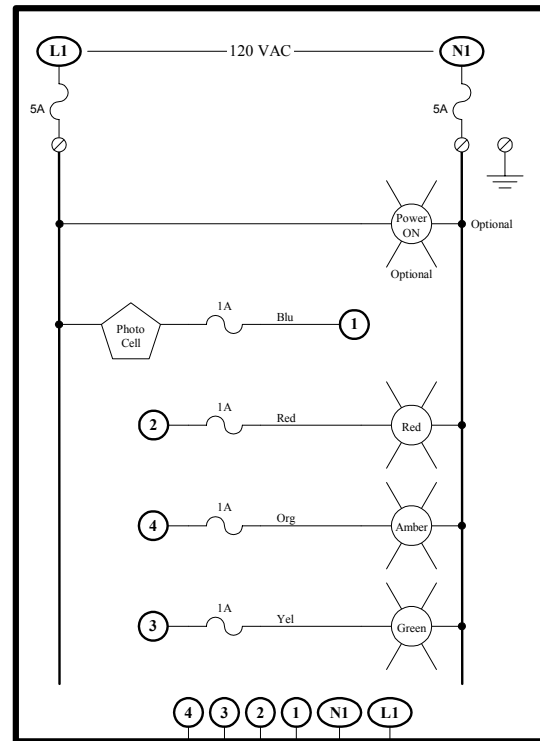

**Appendix DD – Selected Photographs – JWR No. 5 Mine**



**Jim Walter Resources, Inc., No. 5 Mine aerial view.**



**Jim Walter Resources, Inc., No. 5 Mine ground view.**

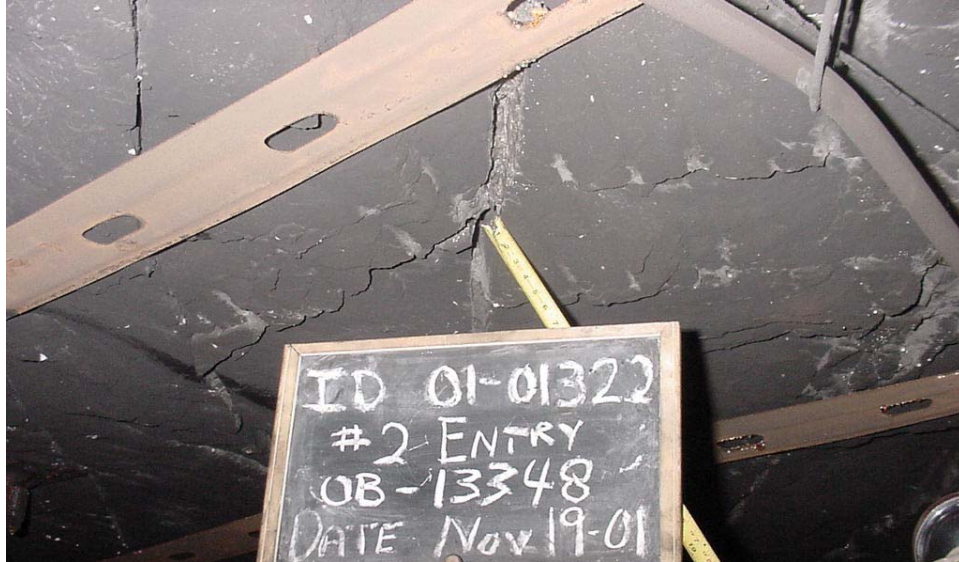

**No. 2 Entry in 4 Section showing joints in mine roof .**



**No. 2 Entry in 4 Section showing joints in mine roof .**





**Crosscut between Nos. 2 & 3 Entries in 4 Section showing rock fall from No. 3 side.**



**No. 2 Entry showing inby side of rock fall in 4 Section.**



**View of rock fall in No. 2 Entry of 4 Section showing broken cable roof bolt.**



**View of rock fall in No. 2 Entry of 4 Section showing the Mary Lee coal seam in the mine roof.**



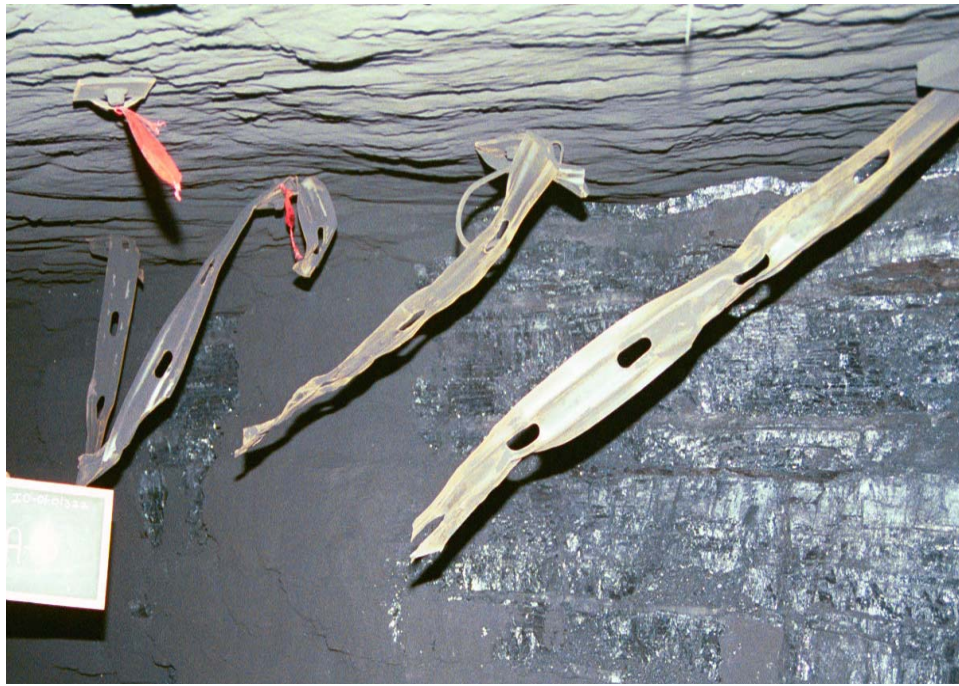

**Last open crosscut showing forces from No. 2 Entry to No. 3 Entry in 4 Section.**



**Face of No. 4 Entry showing damage from forces at roof bolting machine in 4 Section.**



**No. 4 Section track entry block light showing front of block light.**



**No. 4 Section track entry block light showing inside of block light.**





**No. 3 Entry (Conveyor Belt Entry) showing destructive forces looking in by in 4 Section.**



**No. 3 Entry showing destructive forces looking out by in 4 Section.**





**Scoop battery from under rock fall on 4 Section showing terminal contact with battery tray.**



**Scoop battery from under rock fall on 4 Section showing terminal damage.**