

SECTION III
2018
Bench Bio Pak
240-R RULES



2018 BENCH BIOPAK 240-R CONTEST RULES

INDEX

Section III

<u>Title</u>	<u>Page</u>
Rules Governing 2018 Bench BioPak 240R Contest and Interpretations of Discount Cards	1
Statements of Fact (Bench Contest)	10
Identification of Parts.....	19

**RULES GOVERNING 2018 BENCH BIOPAK 240-R CONTEST
AND INTERPRETATIONS OF DISCOUNT CARDS**

1. Each participant must be under guard before the start of the Contest in a location assigned by the Chief Judge and must remain continuously under guard until time to work the problem. Information for bench problem design is available on the MSHA website WWW.MSHA.Gov in the Mine Rescue section under 240R Designers Resources. Participants under guard must be in a location where they will be unable to obtain any information concerning the problem to be worked. Any participant receiving information concerning a Contest problem prior to starting to work the problem will be disqualified by the Chief Judge and the Assistant Chief Judge. No person, except guards and Contest officials assigned to give the written examination, will be allowed to communicate with any participant under guard. Those who have performed will not be permitted to communicate with any participant awaiting their turn to perform.
2. Any indication of receiving unauthorized information during the working of the problem may result in disqualification as determined by the Chief Judge and the Assistant Chief Judge. No one except judges, Contest officials, and working participants will be permitted in the work area, unless special approval is given by the Chief Judge. Communication with bench participants, except for the judges, is prohibited. News media and photographers who wish to be in the working area must receive permission from the Director and be accompanied by a Contest official.
3. Any bench participant not in place and ready at the time specified will be disqualified from the Contest.
4. The bench participant will be provided with two BIOPAK 240-R apparatus (one disassembled, one assembled), a Test kit, a stopwatch, leak detector fluid and a tool kit. Only the tools and fluid provided will be used for testing and assembly of the apparatus. The work at the bench will consist of (1) a visual examination of a disassembled BIOPAK 240-R and the proper assembly and preparation for use in rescue work. This will include correcting any predetermined problem(s) so that the apparatus is in proper working order. This visual examination, correcting predetermined problem(s), and proper assembly can be done at any time allowed for working of the problem. (2) Test the assembled BIOPAK 240-R apparatus with a Test Kit, and correct the predetermined problem(s) so that the apparatus is in proper working condition. Except for removing the face piece storage plug

from the breathing hoses, the assembled BIOPAK 240-R apparatus cannot be disassembled to look for problems, until the apparatus fails a test. When testing is completed on the assembled BIOPAK 240-R apparatus, the hoses shall be removed from the tester, connected to the face piece, and the upper housing installed. This shall be done before the clock is stopped.

5. Spare parts to correct the predetermined problem(s) will be provided once the bench participant has specifically identified the problem. This will require the participant to point out the exact location of the deficiency. (Example: High pressure leak in circuit. Participant will identify the location of the leak.)
6. When an unplanned deficiency is encountered with the apparatus, the participant will be notified by the judges that the deficiency is not part of the problem. The judge will stop the clock, and any time used to correct the deficiency will not be charged to the working time. However, the process of verbal elimination shall not be used by the bench participant to find the predetermined problem(s). If it becomes obvious to the judges that this is occurring, the first offense will result in a warning, the second offense a discount, and the third offense could result in disqualification as determined by the Chief Judge. (Example: Participant verbally identifies a deficiency with every part of the Facemask when only one predetermined problem exists.)
7. The bench participant will not be allowed to bring any materials, written information, or records to the work site.
8. Tests will be performed in sequence on the assembled BIOPAK 240-R apparatus as outlined in the rules using the standard test procedures with the Test kit as outlined in the BIOPAK Model 240-R User Manual, B5-06-6000-14-0, REV-K, and Benchman Manual, B5-06-6000-15-0 REV-N.
9. A maximum of 30 minutes will be allowed to complete the problem. The bench judge will inform the participant when he has five minutes remaining to work the problem. At the completion of the problem, the judge(s) and the participant will note the working time of the problem with the official timekeeper. Work done after the clock is stopped will not be recognized.
10. Manually abusing or intentionally over or under pressurizing the Tester or Apparatus substantially will be considered abusing the equipment. If the participant is observed abusing the Test kit, the first offense will result in a warning, the second offense will result in a discount, and the third offense could result in disqualification as determined by the Chief Judge.

A. Written Examination of Bench Participant

1. The written examination shall consist of 30 questions. Twenty questions for the written examination will be taken verbatim from the Statements of Facts which will be multiple choice with three choices and each blank shall represent a key word with no more than two consecutive blanks per statement. Ten questions will be taken verbatim from identification of parts. Intentional misspelling of words by the test developer will not be allowed. Multiple choice answers with numbers will either be in the form of numbers written out or numerical. Either version is acceptable. "None of the above" is not acceptable as one of the answers. Thirty minutes will be allowed for the written examination.
2. In special circumstances, individual bench participants may be given oral instead of written examinations by at least two judges. Requests for consideration shall be presented to the Director of the Contest at the time of registration.
3. Bench participants will be separated to the extent possible, and every effort will be made to prohibit discussion of questions and answers among the bench participants.

B. Miscellaneous

1. In the event of ties in the Bench Contest, the number of discounts at bench will be the first tie breaker; the number of discounts on written examination will be the second tie breaker; and the official working time at bench in minutes and seconds will be the third tie breaker.
2. The bench participant and trainer will report to a designated location to review and prepare protests within one hour of notification. Twenty minutes will be given to review and prepare written protests. All protests will be considered by the Chief Judge and his/her Assistant and their decision will be binding.
3. Bench participants must be bonafide employees of the mining industry or members of mine rescue teams designated to fulfill the requirements

of 30 CFR Part 49. This does not exclude bench participants whose team is not participating at the National Contest **or a member of a college mine rescue team.**

4. Disputes with regard to the Bench Contest (except discounts), shall be immediately filed with the Director. Disputes filed shall be in writing and set forth incidents, times, names source of information and act complained against. Complainant shall remain accessible to the Director until the complaint is resolved. A decision by the Director shall be final.
5. Any similar terminology may be used to describe a part such as; cylinder or bottle, etc.

Interpretations of Discount Sheet

A. Written Examination

1. For each incorrect statement _____ 1

B. Time

The time will be recorded in minutes and seconds.

C. Competition at Bench

1. Failure to verbally identify each test being conducted _____ 2

Verbally identify each test being performed.

2. Failure to verbally identify each problem _____ 5

Failure to verbally identify is also interpreted as failure to find the problem.

3. Failure to correct each problem _____ 5

The bench participant shall properly correct the problem and continue with the proper tests. Once a bench participant finds a predetermined problem and does not correct it before continuing with the remaining tests, he/she shall receive a five point discount for continuing without correcting the problem and a pending five point discount for failing to

correct the problem. If all of the remaining tests are properly conducted and passed and the participant returns to the uncorrected problem and corrects it, the pending five point discount will not be assessed. Should the participant continue on from this point and properly conduct all of the remaining tests again, he/she would also have the original five point discount for continuing tests removed.

4. Failure to conduct any visual examination or test on the BIOPAK 240-R, each test_____5
5. Failure to tighten connections properly during assembly or testing, each connection_____1

All connections must be tightened on the apparatus and verbally identified as hand tight or wrench tight at the time the connection is tightened. Failure to verbally identify at the time the connection is being tightened will result in a one point discount for each. Zero adjustment of the Mag. Gauge shall be made on the tester prior to connecting the breathing hoses to the tester.

This includes:

- Vent Valve Assembly - hand tight
- Diaphragm Worm Gear Clamp - wrench tight
- Flow Restrictor - wrench tight
- Breathing Hose Worm Gear Clamps - wrench tight
- Add and Constant Fittings - hand tight
- Center Section Lid - hand tight
- Center Section ¼ Turn Pins - hand tight
- Cylinder connections - hand tight
- Adapter to - Facemask hand tight
- Test fixture connections - hand tight

6. Failure to comply with rules not covered in discount sheet, each infraction_____2

If the discount is not listed on the discount sheet, and if it is not covered under one of the approved rules of the Contest, do not improvise a discount to cover the suspected violation.

D. Visuals

1. Failure to conduct a proper visual examination of the Upper and Lower Housing/harness _____ 1

The visual examination will include an examination of the harness assembly, lower housing, upper housing, ~~seal~~, outlet tube O-ring, external gauge, O2 regulator and RMS. Failure to examine and verbally identify the examination will result in one discount for each. (Maximum 4 points)

2. Failure to conduct a proper visual examination of the center section assembly _____ 1

The participant will verbally identify that the diaphragm is being examined for pliability and signs of deterioration. The participant will verbally identify that the O-ring and sealing edges are being examined for signs of damage and lubrication. The participant will verbally identify that the Demand Valve Assembly, PCM and Moisture Pads are being examined for damage. Failure to examine and verbally identify the examination will result in one discount for each. (Maximum 4 points)

3. Failure to conduct a proper visual examination of the carbon dioxide scrubber _____ 1

A proper examination includes a visual inspection for defects and damage of carbon dioxide scrubbers, O-rings and Moisture Control Pad. The participant will verbally confirm the expiration date has not expired. Failure to examine and verbally identify the examination will result in one discount for each. (Maximum 3 points)

4. Failure to conduct a proper visual examination of the center section lid assembly _____ 1

The visual examination will include an examination for defects and damage of the assembly, O-ring seal (lubrication), ice canisters, coolant lids and sealing edges. Failure to examine and verbally identify the examination will result in one discount for each. (Maximum 2 points)

5. Failure to conduct a proper visual examination of the O2 Cylinder _____ 1

A proper cylinder examination includes a visual inspection of the cylinder. The participant will verbally identify the cylinder pressure on the gauge, the pressure rating on cylinder and the latest hydrostatic test date. Participant will inform the judge if the cylinder pressure is less than 1,500 PSI. Failure to examine and verbally identify the examination will result in one discount for each. (Maximum 3 points)

6. Failure to conduct a proper visual examination of the hoses _____1

The participant will verbally identify that the hoses are being inspected for pliability and signs of deterioration. Stretching or manipulating the hoses with a massaging action will be part of this examination. The participant will verbally identify that the sealing edges, are being examined for signs of deterioration. (Install Arrows Up) The participant will verbally identify that the Adapter Assembly O-Ring is being inspected for damage and lubrication. Failure to examine and verbally identify the examination will result in one discount for each. (Maximum 2 points)

7. Failure to conduct a proper visual examination of the Facemask ___1

The visual examination will include an examination of the head strap assembly, mask body, sealing edges, nose cup, the lens/anti-fog insert, speech diaphragms and magnetic wiper. Failure to examine and verbally identify the examination will result in one discount for each. (Maximum 4 points)

8. Failure to have Visual Apparatus fully assembled. (Ready for use) ___2

E. Tester

1. Failure to conduct a proper constant flow test _____2

Remove the constant add line and connect a test flow meter to the center section constant add feed line. Open O2 cylinder valve and observe the test flow meter while holding the test flow meter in a level position. The flow reading on the flow meter should be between 1.6 and 2.4 LPM. Participant will verbally state flow reading. Close the O2 cylinder valve. Remove test flow meter. Reconnect constant add feed line to apparatus. The definition of "Completing the Flow Test" shall be determined when the contestant removes the upper housing cover,

attaches the flow meter to the constant flow port and turns the oxygen cylinder ON and VERBALLY states the reading on the flow meter.

2. Failure to conduct a proper Demand Valve Functional test_____2

Remove the Facemask storage plug from the front of the Facemask adapter and install the leak test plug onto the Facemask adapter. Attach one end of the test kit rubber tubing to the leak test plug and the other end to the input port of the test kit. Verify that the SCBA has no pressure contained within the breathing chamber by a zero reading on the test kit pressure gauge. Open the oxygen cylinder valve and listen for the sound of gas flowing into the breathing chamber. The sound of oxygen flowing into the breathing chamber shall cease within approximately 1-3 seconds.

3. Failure to conduct a proper Emergency Bypass Functional test_____2

Fill the SCBA with oxygen by depressing the emergency bypass one time for no more than 1-2 seconds. The sound of gas flowing into the center section shall be observed. The gas flow shall cease when the bypass valve button is released.

4. Failure to conduct a proper Vent Valve Functional test_____2

Complete filling the SCBA with oxygen by depressing the emergency bypass one time for an additional 1 second, if needed. Observe the test kit pressure gauge; the reading will be at or below 2 inches of water column. Verbally state the final reading. Close O₂ cylinder valve. Vent the pressure from the SCBA and remove rubber tubing and leak test plug.

5. Failure to conduct a proper low pressure leak test_____2

Install the leak test plug onto the Facemask adapter and attach one end of the test kit rubber tubing to the leak test plug and the other end to the input port of the test kit. Verify that the SCBA has no pressure contained within the breathing chamber by a zero reading on the test kit pressure gauge. Insert two test keys into the keyholes in the back of the lower housing. Open the oxygen cylinder valve to pressurize the apparatus and tester. Gently depress the bypass valve to increase the reading to approximately 3 to 4 inches water column. Close the oxygen valve and fully depress the bypass valve. Immediately use the test kit bleed valve to adjust the SCBA pressure to 6-8 inches

water column pressure. Allow the SCBA's pressure to stabilize at 6-8 inches water column of pressure. After one minute, the pressure gauge of the test kit shall indicate no less than 0.2-inches water column pressure below the stabilized starting pressure. An increase in pressure of 0.2 inches Water Column or greater on the test kit requires a restart of the one-minute timed test. Vent the pressure from the SCBA and remove rubber tubing, leak test plug, and keys. Replace Facemask adapter plug.

6. Failure to conduct a proper RMS Gauge and TRIM test_____2

While looking at the gauge and TRIM, open the oxygen cylinder valve and listen for the alarm test and observe the gauge and TRIM color sequence. The gauge will reach full pressure (approximately 60 seconds). The alarm and TRIM will go through a startup self-check: Alarm, Red, Green, Blue light sequence, then a flashing green light. Check for stabilization of alarm lights. Verify that the oxygen cylinder pressure gauge and the RMS gauge are within +/- 10%. Verbally state the final reading.

7. Failure to conduct a proper High Pressure Leak test_____2

Open the oxygen cylinder with the storage plug installed; inspect each plumbing connection and Flow Restrictor with Lec-Tec for a minimum of 60 seconds. During the test the contestant must depress the emergency by-pass to properly check the output fitting of the emergency by-pass. Contestant can depress the by-pass to check for leaks on the output side of the by-pass at any time during the 60 second test. The 60 second test begins when Lec-Tec has been applied to the last fitting, during the test additional fluid may be applied as the contestant checks for leaks.

8. Failure to conduct a proper Low Pressure Alarm Functional test_____2

Turn off the oxygen cylinder and allow the BioPak to slowly reduce system pressure. The low alarm must activate between 650-1000 psig and is indicated by a flashing red light and audible alarm. (Verbally state reading) The RMS will automatically power down once the system pressure is dropped below 25 psig. Vent the SCBA of pressure and remove test equipment.

9. Failure to have Test Apparatus fully assembled. (Ready for use) Note: Breathing hoses do not need to be in straps on test apparatus ____2

**STATEMENTS OF FACT
BENCH BIOPAK 240-R CONTEST**

1. Use only exact replacement parts in the configuration as specified by the manufacturer. User/Benchman: Cautions and Limitations, Special or Critical User's Instructions)
2. The battery is to be changed in fresh air only. User/Benchman: Cautions and Limitations, Special or Critical User's Instructions)
3. MSHA approved for use with one of the following 9-Volt batteries only:
Eveready
Panasonic
Rayovac
Duracell
(Remote Monitoring System MSHA Electronic Approval Page)
4. Never substitute, modify, add or omit parts. User/Benchman: Cautions and Limitations, Special or Critical User's Instructions)
5. Prior to using the BioPak 240 Revolution it must be determined that the user is medically fit. User/Benchman: Cautions and Limitations, Special or Critical User's Instructions)
6. Always handle oxygen cylinders with care to prevent damage. User/Benchman: Cautions and Limitations, Special or Critical User's Instructions)
7. Do not open the cylinder valve in the presence of open flame, sparks or high radiant heat. User/Benchman: Cautions and Limitations, Special or Critical User's Instructions)
8. Oxygen will enhance the combustion of other materials so that materials that normally will not burn in air may burn in oxygen-rich atmospheres; and, materials that do burn in air will burn more vigorously and at a higher temperature in oxygen-rich atmospheres. User/Benchman: Cautions and Limitations, Special or Critical User's Instructions)
9. Oxygen will not cause materials to ignite without the presence of an ignition source. User/Benchman: Cautions and Limitations, Special or Critical User's Instructions)

10. The use of an SCBA will add to the workload and stress of the user. User/Benchman: Cautions and Limitations, Special or Critical User's Instructions)
11. The BioPak 240 Revolution is suitable for respiratory protection entry into and escape from oxygen deficient atmospheres with a temperature as low as -5 degrees F (-5F) (-20C). (Users/Benchman Cautions and Limitations or Critical User's Instructions)
12. The BioPak 240 Revolution is approved when the oxygen cylinder is fully charged with compressed medical or aviation grade oxygen at 3000 psi. User/Benchman: Cautions and Limitations, Special or Critical User's Instructions)
13. Allow the oxygen cylinder to cool after filling to determine the correct pressure. User/Benchman: Cautions and Limitations, Special or Critical User's Instructions)
14. A foreign gas may cause cylinder corrosion. User/Benchman: Cautions and Limitations, Special or Critical User's Instructions)
15. Always check for a current hydrostatic test date. User/Benchman: Cautions and Limitations, Special or Critical User's Instructions)
16. DOT requires carbon fiber wrapped aluminum cylinders be tested by an approved facility on a 5-year cycle from the date of manufacture. User/Benchman: Cautions and Limitations, Special or Critical User's Instructions)
17. An unapproved facepiece will compromise the protection provided to the user by the SCBA. User/Benchman: Cautions and Limitations, Special or Critical User's Instructions)
18. A good facepiece seal is important to achieving full protection and proper SCBA duration. User/Benchman: Cautions and Limitations, Special or Critical User's Instructions)
19. Users should conform to MSHA/NIOSH guidelines concerning facial hair and the use of facemasks. (Users/Benchman Cautions and Limitations or Critical User's Instructions)

20. Replace the battery when the low battery alarm has activated, after 200 hours of use or every 6 months whichever comes first. (Benchman section 3.4)
21. The connectors of the monitoring device may only be connected to a Bio marine BioPak 240R breathing Apparatus oxygen regulator, manifold block and breathing chamber. User/Benchman: Cautions and Limitations, Special or Critical User's Instructions)
22. The fiber optic cable may only be connected to the BioPak 240R remote gauge assembly. User/Benchman: Cautions and Limitations, Special or Critical User's Instructions)
23. Turn-Around maintenance procedures should be performed as soon as possible after each use. (Benchman Section 3.1)
24. It is acceptable to leave the oxygen cylinder in place until after washing and disinfecting has been completed. (Benchman Section 1.2)
25. Immediately after completion of BioPak use, remove the used CO2 scrubber canisters. (Benchman: Section 1.2)
26. DO NOT submerge the Alarm Module during turn-around maintenance. (Benchman: Section 1.3)
27. Do not allow any fluids to contact the ~~in~~ input port of the pressure regulator. (Benchman: Section 1.3)
28. Use only cleaners and disinfectants that are approved by Bio marine. (Benchman: Section 1.3)
29. If Cleaning is not immediately possible after each use, at a minimum remove and discard the CO2 scrubber and moisture pad. (Benchman: Section 1.3)
30. Remove the oxygen cylinder making sure the ~~seal-washer~~ outlet tube O-ring remains in place and install the regulator cover. (Benchman: Section 1.2)
31. Allow all components to remain wetted by the cleaning solution a minimum of 10 minutes. (Benchman: Section 1.3)
32. Thoroughly rinse all components in clean water to remove all disinfectant solution. (Benchman: Section 1.3)

33. C.O.P.D. could limit or prevent the use of the BioPak 240 Revolution. (User/Benchman: Cautions and Limitations, Special or Critical User's Instructions)
34. Place freeze forms onto a level surface in a freezer for a minimum of 8 hour period at a temperature of 10 degrees F or less. (Benchman: Section 1.4)
35. If the optional magnetic wiper is utilized soak both chamois surfaces of the wiper pieces with water. (User: Section 3.2)
36. The manual(s) are the minimum recommended procedures for maintaining the BioPak 240R. (User/Benchman: Cautions and Limitations, Special or Critical User's Instructions)
37. Failure to follow the minimum procedures presented in the manual(s) may violate government or agency approvals as well as void the manufacturer's warranty. (User/Benchman: Cautions and Limitations, Special or Critical User's Instructions)
38. To prevent mold growth remove the moisture control foam pads after each use (Benchman: Section 1.3)
39. Do not pre-pack any BioPak that will be stored at temperatures at or below 32 degrees F. (Benchman: Section 1.12)
40. Pre-packing the BioPak 240 R with carbon dioxide scrubbers is only permitted when utilizing Orbsorb carbon dioxide scrubber. (Benchman: Section 1.12)
41. Pre-packed carbon dioxide scrubbers may only be stored in the apparatus for a maximum period of 1-year. (Benchman: Section 1.12)
42. Moisture control sponges must be installed dry when pre-packing the BioPak. (Benchman: Section 1.12)
43. Apparatus that are pre-packed with the carbon dioxide scrubber shall be stored within the specific storage temperature and humidity levels and must be sealed air-tight in the apparatus. (Benchman: Section 1.12)
44. Failure to install the moisture pad will result in scrubber flooding and cause elevated carbon dioxide levels in the inhalation gas. (Benchman: Section 1.12)
45. Users are not permitted to mix versions of the Orbsorb within a BioPak. (Benchman: Section 1.12)

46. Install two carbon dioxide scrubber canisters into the breathing chamber making sure that they are properly aligned and fully seated. (Benchman: Section 1.12)
47. The alarm system battery shall be replaced after 200-hours of use, every 6-months or after the alarm system low battery alarm flashes with corresponding horn sounding. (Benchman: Section 3.4)
48. The oxygen cylinder must be fully charged to above 1500 psi to perform a high pressure leak test. (Benchman: Section 2.6)
49. Use caution when installing the flow restrictor to insure that the O-ring does not roll out of its gland. (Benchman: Section 3.5)
50. The Cylinder should be inspected regularly for signs of damage to the outer wrapping. (Benchman: Section 3.3)
51. The Turn-Around Maintenance Tag should be attached to the apparatus in a prominent location to show completion of all maintenance steps. (Benchman: Section 1.1)
52. In addition to normal Turn-Around Maintenance, the SCBA shall be visually inspected and pressure tested on a monthly basis if the apparatus is being used at least once a month or is placed in long term storage. (Benchman Section: 2)
53. BioPaks that have been placed in long term storage should have the Long Term Maintenance Procedure conducted every-6 months. (Benchman: Section 2)
54. The LED indication will cease when the pressure gauge reads less than 25 psi. (Benchman: Section 1.10)
55. Never pry an O-ring from its glands with a screwdriver. Remove O-rings by hand or with the pick tool provided in the service kit. (Benchman: Section 3.2)
56. Cristo-Lube and Dow-111 are the only lubricants approved for use in the apparatus. (Benchman: Section 3.2)
57. Never lubricate the ~~sealing washer outlet tube~~ O-ring that sits between the oxygen cylinder and the pressure regulator. (Benchman: Section 3.2)

58. Cylinders that have been hydro-static tested shall be cleaned for high-pressure oxygen service per national standards. (Benchman: Section 3.2)
59. Cylinders are to be retired from service 15-years after the date of manufacture. (Benchman: Section 3.2)
60. The Alarm module will require replacement if any damage to the housing is discovered. (Benchman: Section 3.)
61. If the flow does not meet the requirements of the table in the Bench Manual the flow restrictor will need replacement. (Benchman: Section 1.8)
62. A good facemask seal is important to achieving full protection and duration. (User/Benchman: Cautions and Limitations, Special or Critical User's Instructions)
63. Personnel who intend to use protective breathing equipment in a dangerous atmosphere must have the proper training, temperament and experience. (User/Benchman: Cautions and Limitations, Special or Critical User's Instructions)
64. A clean shaven user will significantly increase the chances of achieving an adequate face seal. (User/Benchman: Cautions and Limitations, Special or Critical User's Instructions)
65. The ongoing effectiveness and reliability of any protective breathing equipment is dependent upon the user's standard of care in maintaining the equipment. (User/Benchman: Cautions and Limitations, Special or Critical User's Instructions)
66. The BioPak has been tested for intrinsic safety in methane-air mixtures only. (User/Benchman: Cautions and Limitations, Special or Critical User's Instructions)
67. The battery is to be changed in fresh air only. Do not change in hazardous areas. (User/Benchman: Cautions and Limitations, Special or Critical User's Instructions)
68. The BioPak is a Self-Contained Closed Circuit Pressure Demand type certified as Entry and Escape with a 4-hour duration. (Benchman: Section 6)
69. The constant Add is 1.8 liters average. (Benchman: Section 6)

70. The Demand Add flow is a minimum 80 liters per minute. (Benchman: Section 6)
71. The oxygen cylinder has a volume of 440 liters at 3000 psi. (Benchman: Section 6)
72. The BioPak breathing chamber has a Tidal Volume greater than 6 liters. (Benchman: Section 6)
73. For extreme temperature ranges, the BioPak should be configured with ice coolers. When ambient temperatures are greater than 140 degrees F the recommended duration is no more than 15 minutes and is limited by human endurance. (Benchman: Section 6)
74. The emergency Add has a minimum flow rate of 80 liters per minute. (Benchman: Section 6)
75. The BioPak operational conditions as it relates to relative humidity is 0 to 100%. (Benchman: Section 6)
76. BioPak weight fully charged is 34 pounds. (Benchman: Section 6)
77. Do not re-use CO2 scrubber chemical. (User/Benchman: Cautions and Limitations, Special or Critical User's Instructions)
78. The flow test results at 0-5280 feet at a cylinder pressure of 1500-2000 shall be 1.8-2.4 liters per minute. (Benchman: Section 1.8)
79. During an alarm test the LED indication should turn to a flashing red with a horn sounding when the pressure gauge reads between 650-1000 psi. (Benchman: Section 1.10)
80. Do not allow oil, grease or other foreign materials to come in contact with cylinder, cylinder valve or cylinder pressure regulator to prevent possible ignition. (User/Benchman: Cautions and Limitations, Special or Critical User's Instructions)
81. The end of service life or low Oxygen alarm is a flashing red light and horn sounding. (User: Section 2.7)
82. The flashing blue light indicates an Ice Reminder. (User: Section 2.7)

83. The pressure gauge is protected against sudden loss of oxygen in the event of a gauge line severing by a manual disconnect located at the gauge pass through point of the housing. (User: Section 2.7)
84. A Pacemaker or other Cardiac Condition could limit or prevent the use of the BioPak 240 Revolution. (User/Benchman: Cautions and Limitations, Special or Critical User's Instructions)
85. Breathing difficulties could limit or prevent the use of the BioPak 240 Revolution. (User/Benchman: Cautions and Limitations, Special or Critical User's Instructions)
86. Claustrophobia or anxiety when wearing a SCBA could limit or prevent the use of the BioPak 240 Revolution. (User/Benchman: Cautions and Limitations, Special or Critical User's Instructions)
87. The instructions provided by the USER and BENCHMAN manuals cannot replace accredited training provided by qualified instructors in the proper and safe use of Bio marine breathing apparatus. (User: Section 1.3)
88. X-Ray evidence of Pneumonia could limit or prevent the use of the BioPak 240 Revolution. (User/Benchman: Cautions and Limitations, Special or Critical User's Instruction)
89. Epilepsy-Grand Mal or Petit Mal could limit or prevent the use of the BioPak 240 Revolution. (User/Benchman: Cautions and Limitations, Special or Critical User's Instructions)
90. Use the 1/4 inch hex driver from the service Kit to remove the flow restrictor. (Benchman Section 3.5)

NOTE: The References listed above for the Statements of Facts can be down loaded for free from Bio-marine's web site.

BioPak 240 Revolution Complete

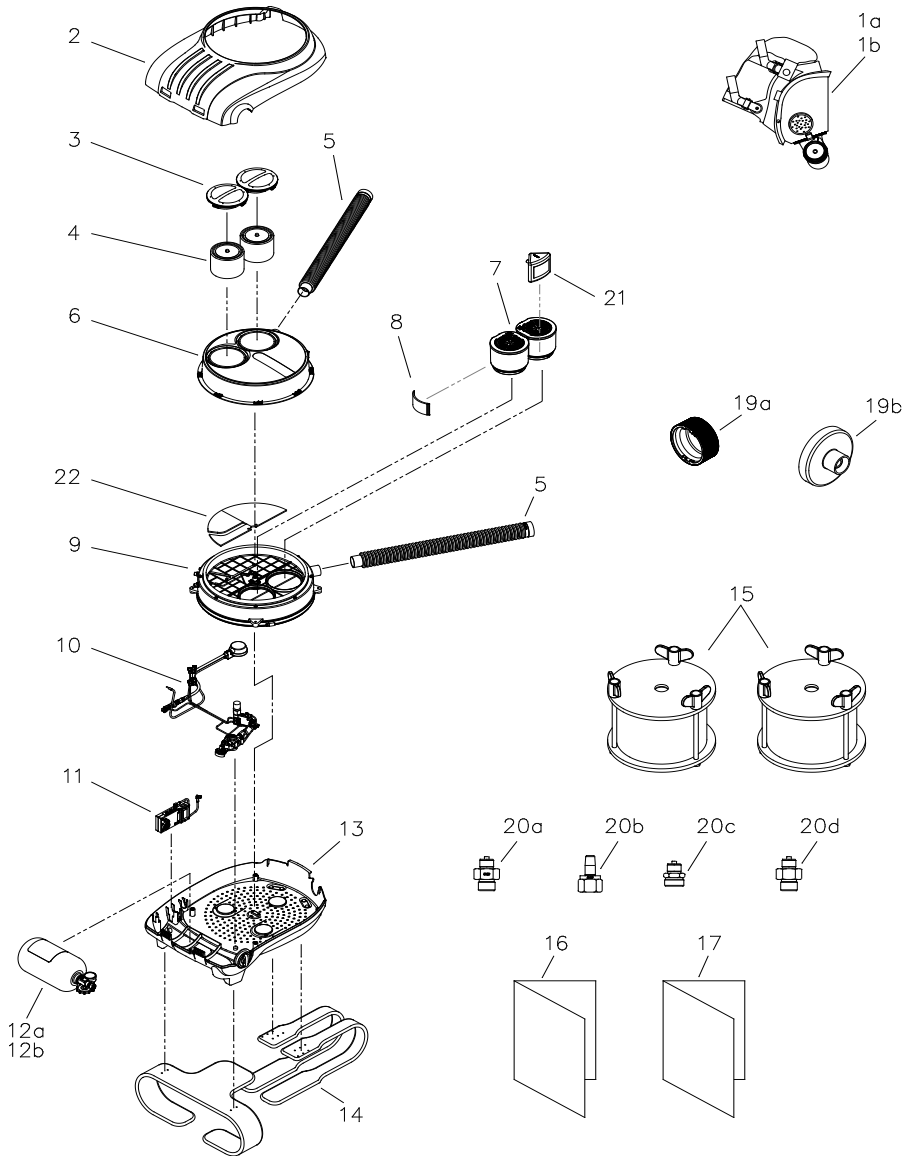

1 Cons. No.	2 Designation	1 Cons. No.	2 Designation
2	Upper Housing Assembly	14	Harness Assembly
3	Coolant Lid	15	Ice Canister Freeze Form
4	Ice Canister	19	Facemask Storage Plug
5	Breathing Hose	21	PCM Heat Exchanger
12	O2 Cylinder	22	Moisture Absorbent Pad Set
13	Lower Housing Assembly		

Lower Housing Assembly

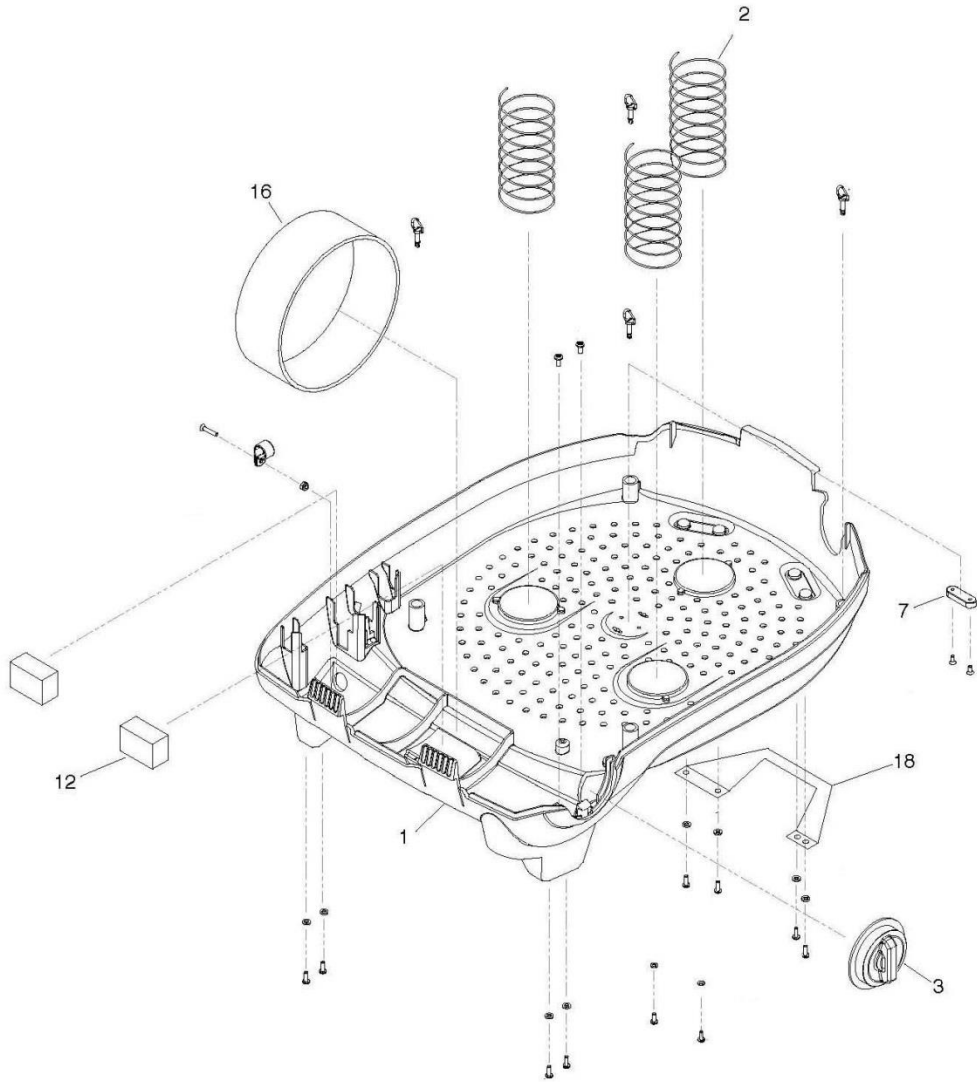

1 Cons. No.	2 Designation	1 Cons. No.	2 Designation
1	Lower Housing Shell	12	Latch Foam Pad
2	Diaphragm Springs	16	Oxygen Cylinder Hold-Down Strap
3	External Oxygen Knob	18	Carrying Handle
7	Vent Spacer		

Pneumatic Assembly

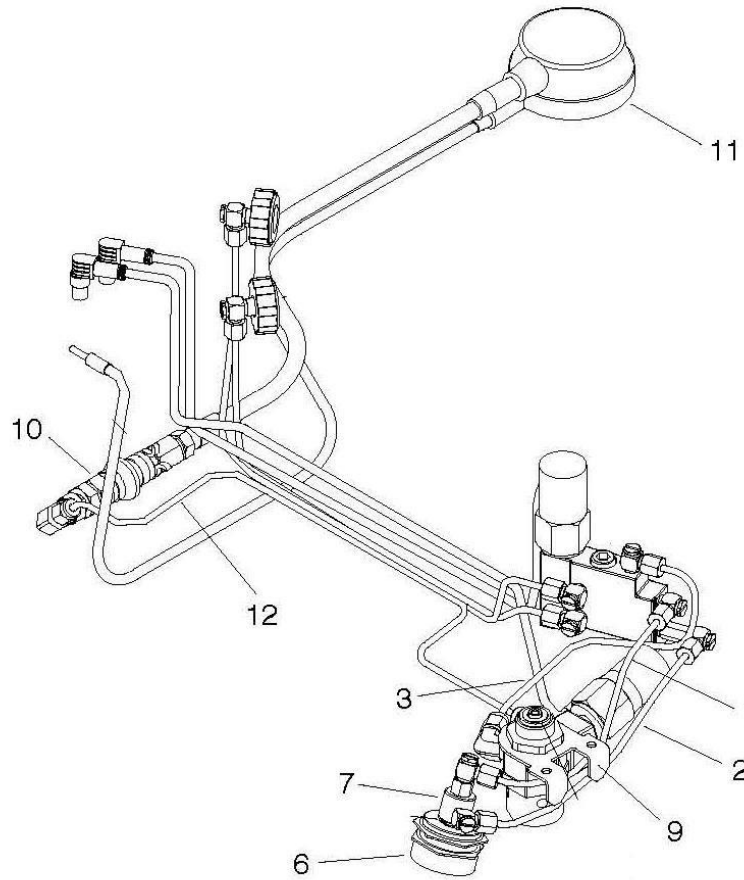

1 Cons. No.	2 Designation	1 Cons. No.	2 Designation
1	Bypass Feed Tube	9	Oxygen Regulator Assembly
2	Bypass Return Tube	10	Remote Gauge Shut Off Assembly
3	Oxygen Feed Tube	11	Remote Gauge Assembly
6	Bypass Valve Push Button	12	Remote Gauge Feed Tube Assembly
7	Bypass Valve		

Manifold Assembly

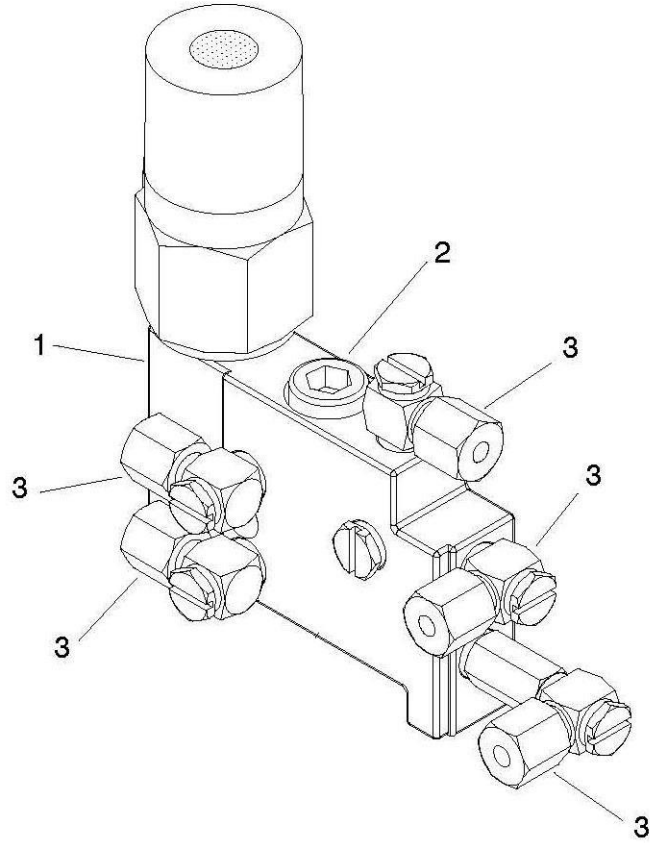

1 Cons. No.	2 Designation	1 Cons. No.	2 Designation
1	Manifold Block w/ Pressure Switch	3	Swivel Elbow Fitting
2	Constant Add Flow Restrictor Assembly		

Center Section Assembly

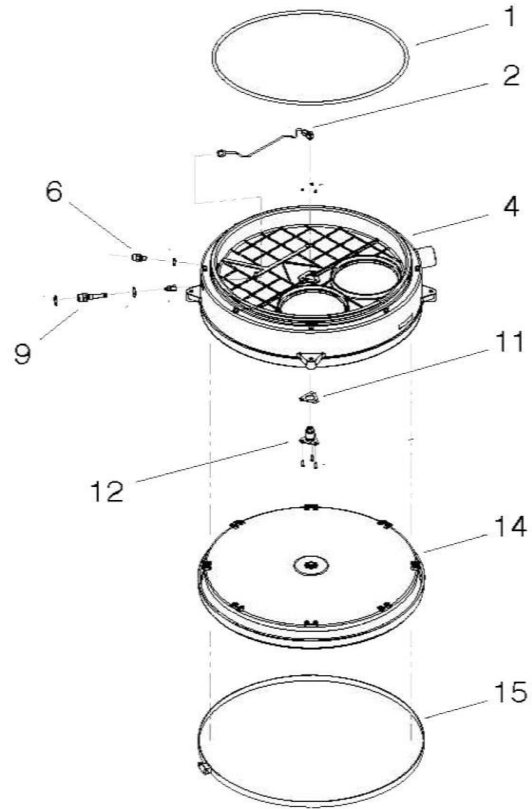

1 Cons. No.	2 Designation	1 Cons. No.	2 Designation
1	Lid O-Ring	11	Demand Valve Gasket
2	Demand Feed Tube	12	Demand Valve Assembly
4	Center Section Body Assembly	14	Flexible Diaphragm
6	Constant Add Fitting	15	Diaphragm Clamp
9	Demand Add Fitting		

Center Section Lid Assembly

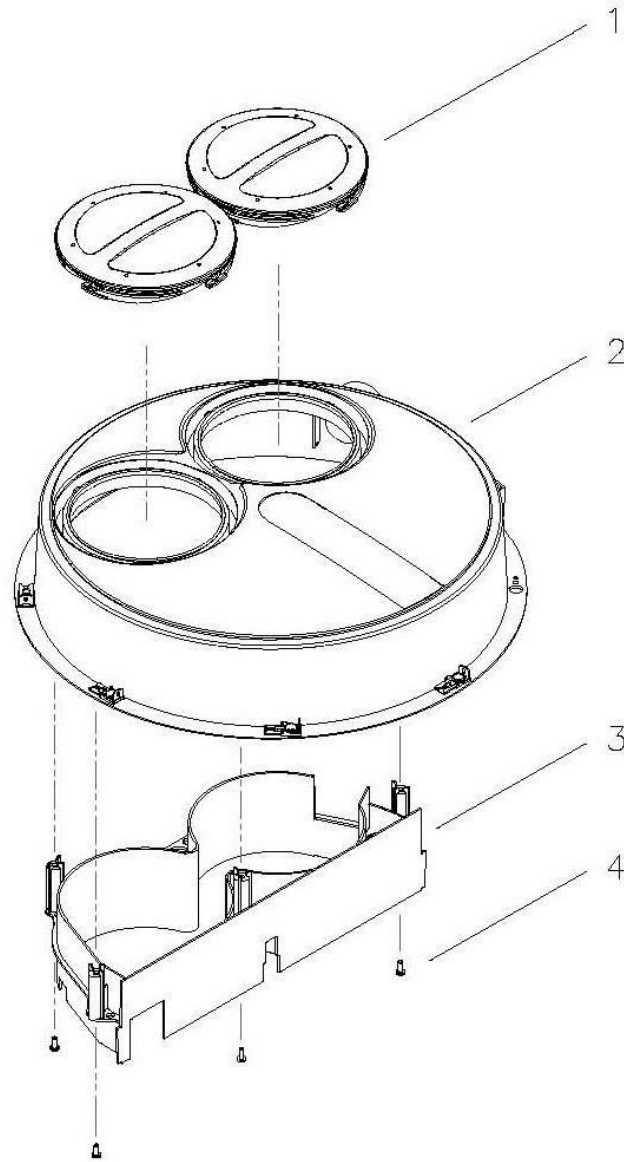

1 Cons. No.	2 Designation	1 Cons. No.	2 Designation
1	Coolant Lid	3	Flow Baffle
2	Center Section Lid	4	Self-Tapping Screws

Diaphragm Assembly

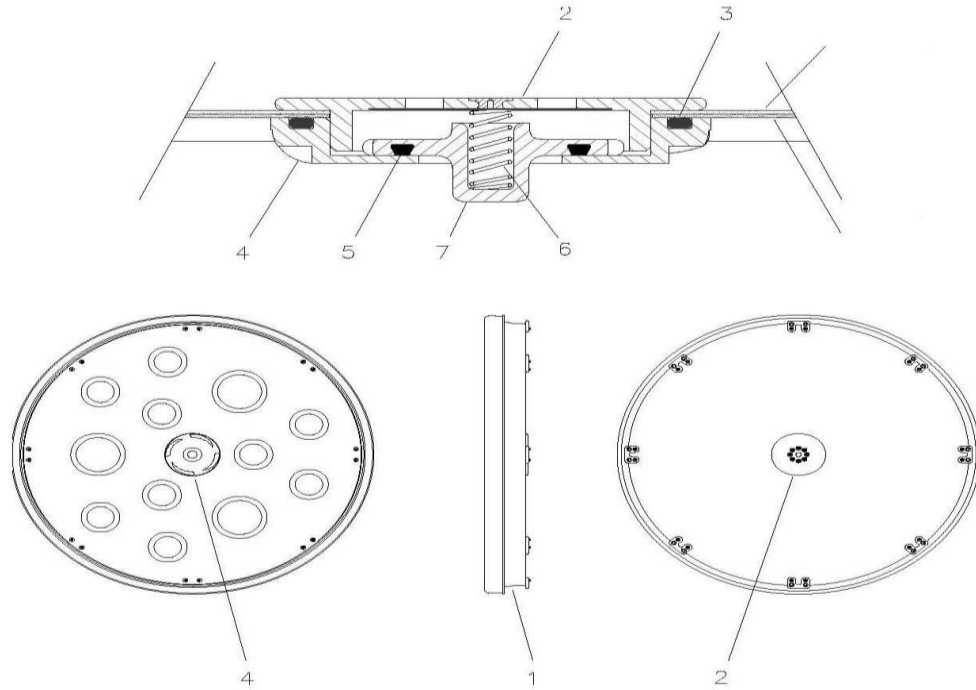

1 Cons. No.	2 Designation	1 Cons. No.	2 Designation
1	Flexible Diaphragm	5	Vent Seat O-Ring
2	Vent Cap	6	Vent Valve Spring
3	Vent Body O-Ring	7	Vent Valve Seat
4	Vent Body		

Breathing Hose

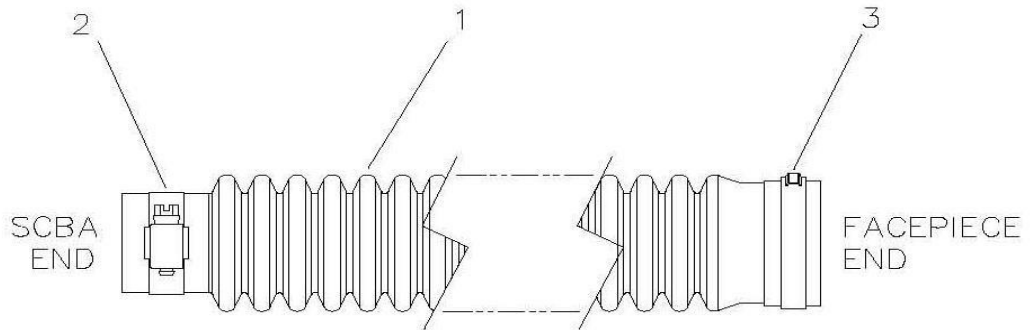

1 Cons. No.	2 Designation	1 Cons. No.	2 Designation
1	Breathing Hose	3	Stepless Ear Clamp
2	Worm Gear Hose Clamp		

Ice Canister Freeze Form

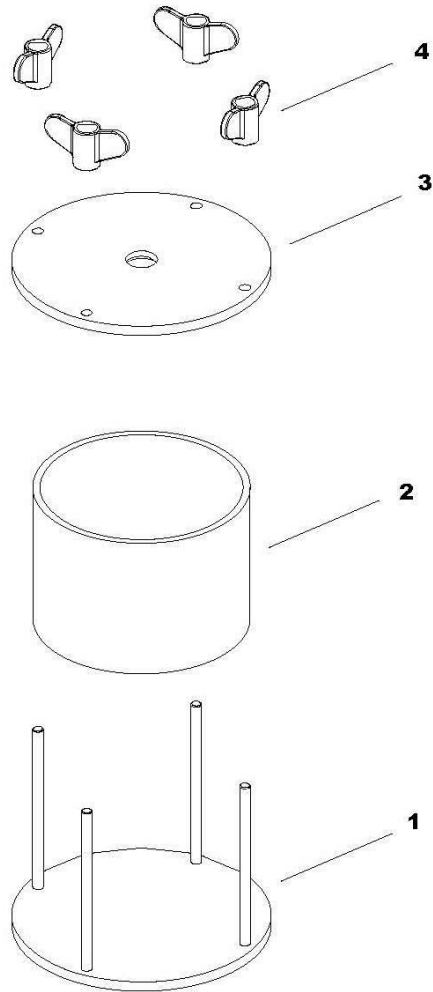

1 Cons. No.	2 Designation	1 Cons. No.	2 Designation
1	Base Assembly	3	Top Plate
2	Freeze Tube	4	Wing Nut

Oxygen Cylinder Assembly

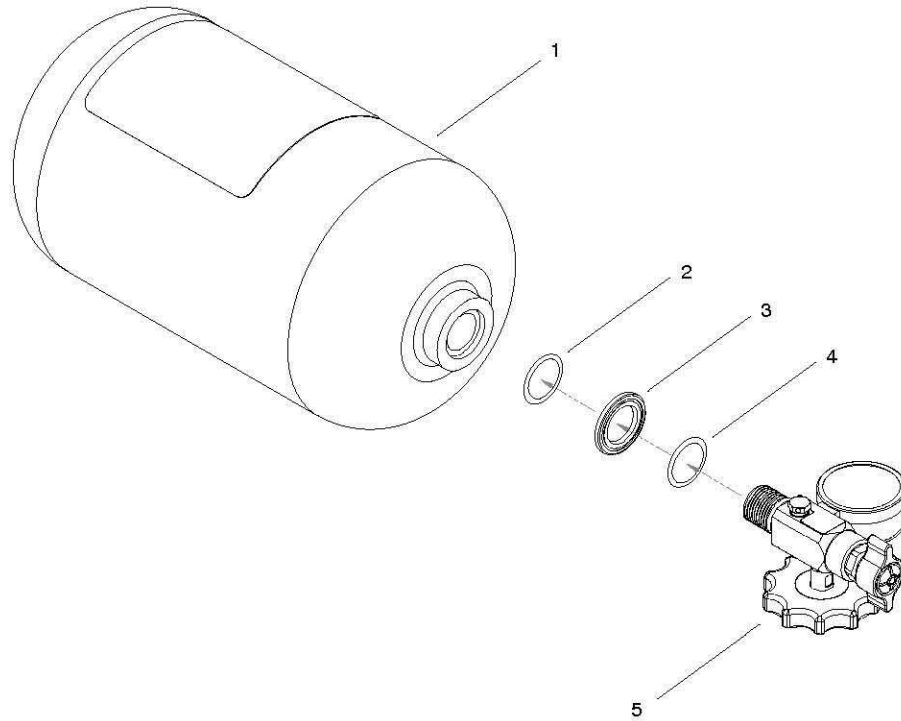

1 Cons. No.	2 Designation	1 Cons. No.	2 Designation
1	Green Cylinder	4	Interior O-Ring
2	Exterior O-Ring	5	Valve Assembly
3	Valve Collar		

RMS Monitoring System

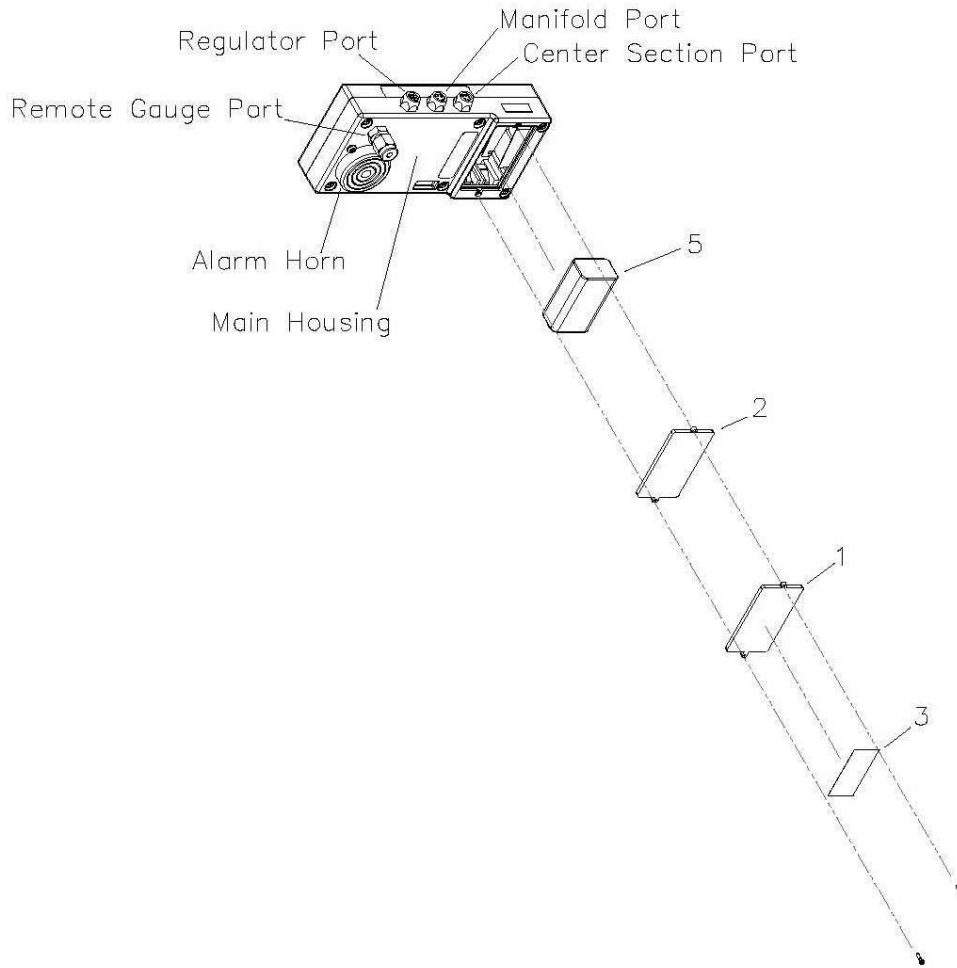

1 Cons. No.	2 Designation	1 Cons. No.	2 Designation
1	Battery Door	3	Battery Door Warning Label
2	Battery Door Gasket	5	9Vdc Battery

Facemask Assembly

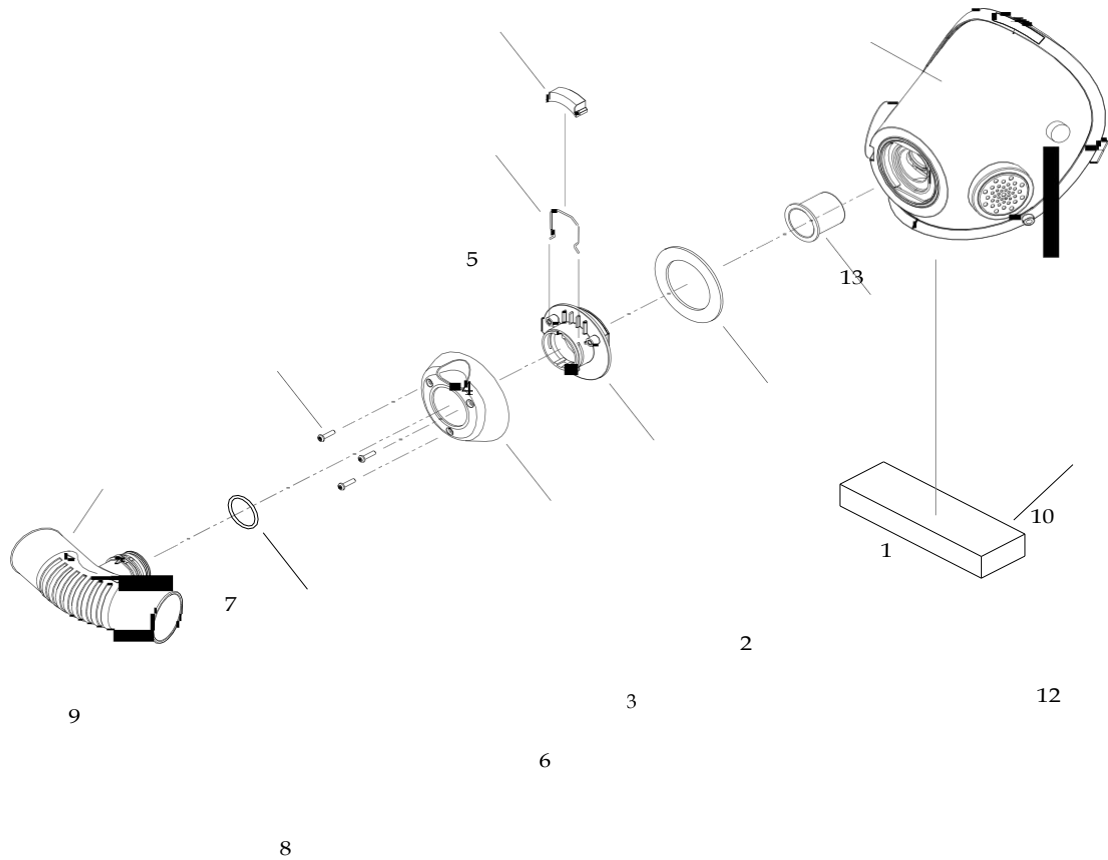

SS

1 ——— 2 Cons. No. ——— Designation	1 ——— 2 Cons. No. ——— Designation
<p>1 ——— Interface Tube 2 ——— Interface Gasket 3 ——— Interface Fitting 4 ——— Clip 5 ——— Button 6 ——— Cowling</p>	<p>7 ——— Locking Pan Head Screw 8 ——— Hose Adapter O Ring 9 ——— AV3500 Hose Adapter 10 ——— Facemask Magnetic Wiper 12 ——— Chin Condensation Pad 13 ——— Lens</p>

AV3500 Facemask-Complete

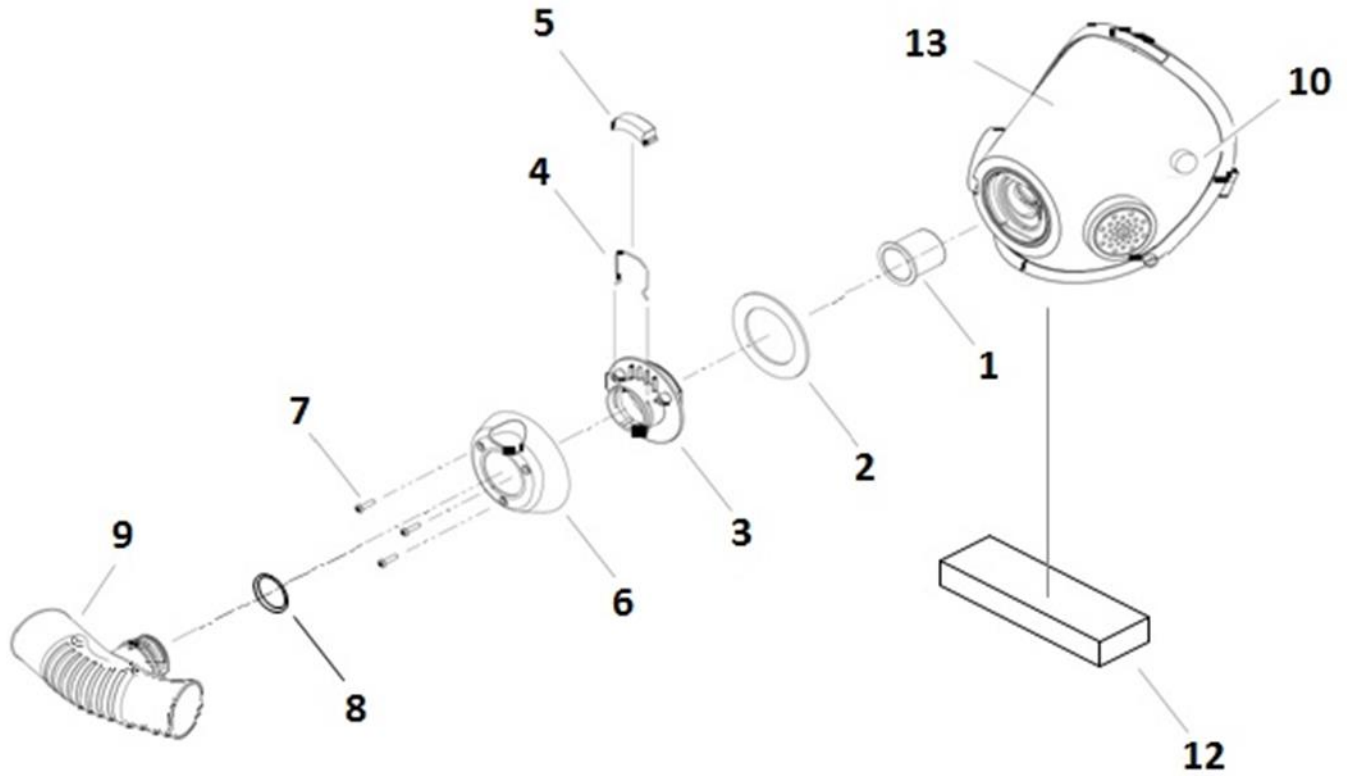

1 Cons. No.	2 Designation	1 Cons. No.	2 Designation
1	Interface Tube	7	Locking Pan Head Screw
2	Interface Gasket	8	Hose Adapter O-Ring
3	Interface Fitting	9	AV3500 Hose Adapter
4	Clip	10	Facemask Magnetic Wiper
5	Button	12	Chin Condensation Pad
6	Cowling	13	Lens

Tool Kit

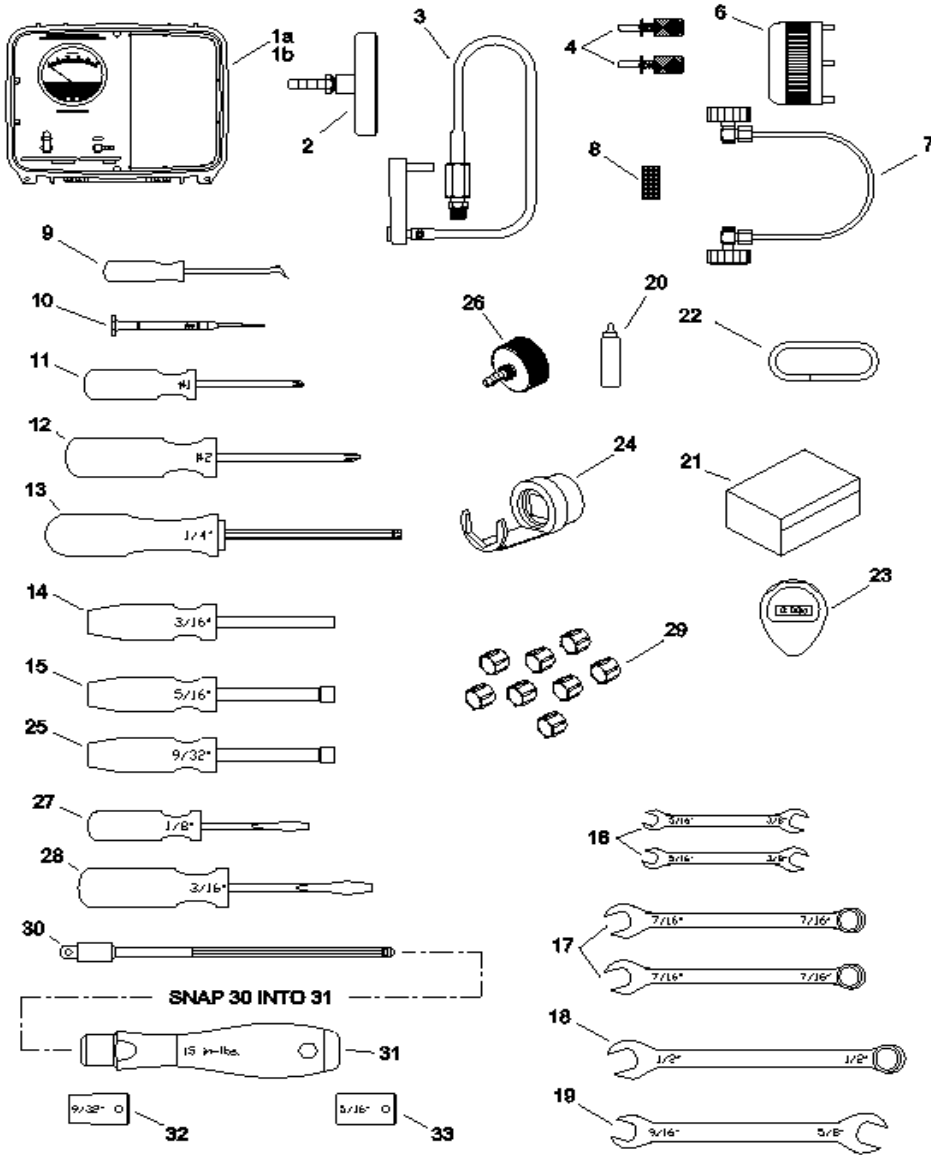

1 Cons. No.	2 Designation	1 Cons. No.	2 Designation
1	Case Assembly	7	Center Section Pneumatic Plug
26	Leak Check Adapter Fitting	9	Combination Pick Tool
3	Flow Test Fixture	13	1/4 - Inch Hex Driver
4	Test Key	20	Leak Detection Fluid
6	Vent Valve Wrench	22	3/8 - Inch OD Rubber Tubing