

ISSUE DATE: 11/28/11
LAST VALIDATED: 3/26/2026

PROGRAM INFORMATION BULLETIN NO. P11-52

FROM: KEVIN G. STRICKLIN
Administrator for
Coal Mine Safety and Health

NEAL H. MERRIFIELD
Administrator for
Metal and Nonmetal Mine Safety and Health

SUBJECT: Potential Shock and Ignition Hazard Involving Permissible and
Non-permissible Battery-Powered Machines

Scope

Underground coal and metal and nonmetal mine operators, independent contractors, Mine Safety and Health Administration (MSHA) enforcement personnel, original equipment manufacturers, repair facilities, and miners' representatives.

Purpose

This Program Information Bulletin is to inform the mining industry of a potential electrical shock and methane/hydrogen ignition hazard involving two-pole male battery connectors/plugs installed on permissible and non-permissible battery-powered machines.

Information

MSHA has identified a shock and ignition hazard that exists on some battery-powered machines having two-pole male battery connectors or plugs installed on the machine's power cable from the main breaker enclosure to the battery. In some two-pole machines, energy stored in the drive controller capacitors can allow voltage to be present at the exposed and unprotected center pin of the disconnected male battery connector/plug.

Not all two-pole machines incorporate the type of capacitor that presents this shock and ignition hazard. Among those machines that do, this hazard is present only when the following combination of factors occurs:

- the machine circuit breaker is not opened before withdrawing the battery connector/plug;
- the connection between the battery and machine breaker enclosure is a two-pole male battery connector or plug;
- the machine circuit breaker has an undervoltage release (UVR) that will be held closed by the energy stored in the drive controller capacitors or is a shunt trip breaker;
- the solid-state drive controller has capacitors charged to battery voltage; and
- the drive controller capacitors do not have a provision to quickly discharge stored energy.

If these factors exist on your permissible or non-permissible battery-powered machines, the following steps should be taken to address the hazard: the machine circuit breaker should be opened before withdrawing the two-pole male battery connector or plug; a clearly visible warning tag should be present on the connector/plug that states, "DO NOT DISENGAGE UNDER LOAD"; and task training should be provided to personnel addressing this hazard. If these steps are not taken, a serious injury could occur.

MSHA is currently working with the machine manufacturers to develop a solution to correct the hazard. Contact the manufacturer of the equipment for additional information.

Good practice entails always opening the circuit breaker before disconnecting a battery plug. Failure to do so could result in serious bodily injury and/or death, as well as creating an ignition source.

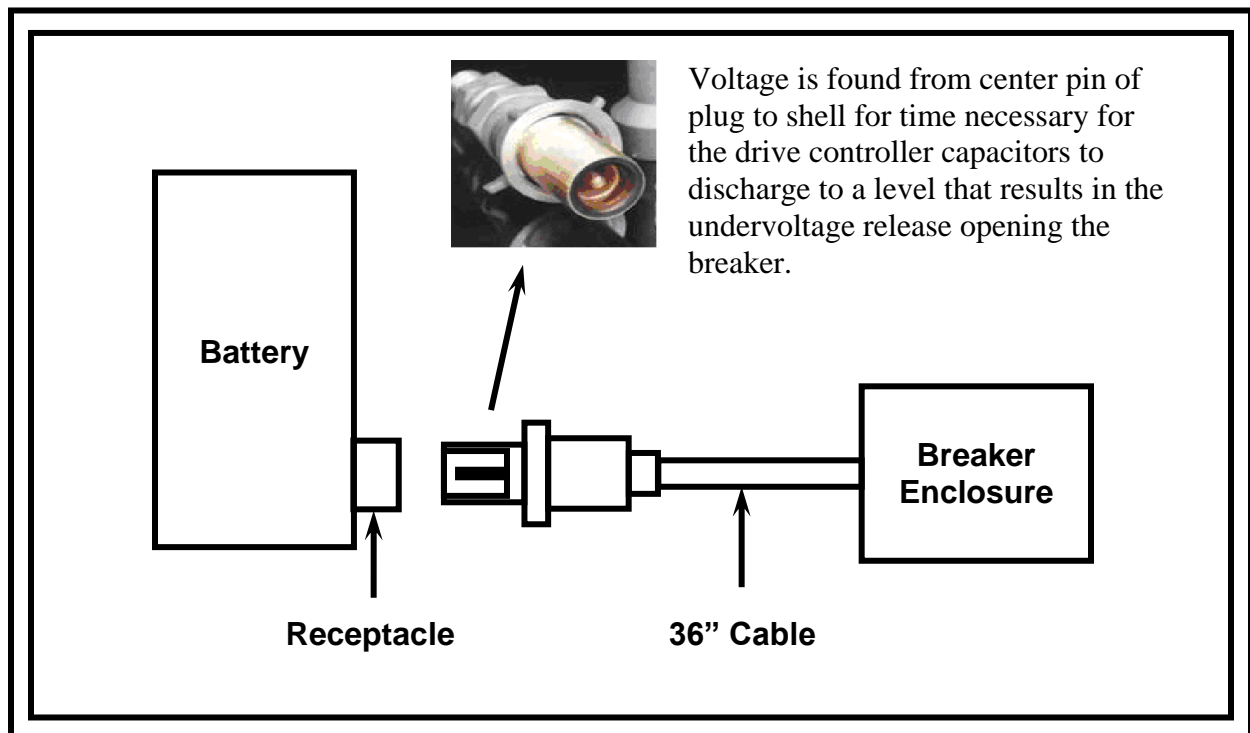

Background

During an examination of a battery-powered scoop, MSHA Coal Mine Safety and Health Enforcement and Technical Support personnel discovered a shock and ignition hazard was present when the two-pole male battery connector from the 36" intramachine cable was withdrawn from the battery while the machine circuit breaker was in the closed position. MSHA has concluded this hazard is due to the large capacitor bank found within the machine's controller. The stored energy is fed back to the main circuit breaker and prevents the undervoltage release from opening. The same shock and ignition hazard may also be created when a shunt trip circuit breaker is used.

Authority

The Federal Mine Safety and Health Act of 1977, as amended, 30 U.S.C. § 801 et seq.; 30 C. F. R. §§ 18.41, 57.14100(b) and 75.512.

Internet Availability

This information bulletin may be viewed on the Internet by accessing MSHA's home page at (<http://www.msha.gov>), choosing Compliance Info, and then Program Information Bulletins.

Issuing Office and Contact Person

Mine Safety and Health Enforcement, Safety Division
Rodney Adamson, (202) 693-9549
E-mail: adamson.rodney@dol.gov

Distribution

MSHA Program Policy Manual Holders
Underground Coal Mine Operators
Underground Metal and Nonmetal Mine Operators
Miners' Representatives
Independent Contractors
Battery Powered Equipment Manufacturers
Repair Facilities