

Mine Safety and Health Administration

Technical Support

Emergency Communication and Tracking Committee
Underground Communication and Tracking Systems Tests at
CONSOL Energy Inc., McElroy Mine

Report of Findings
June 13, 2006

Committee Members

David Chirdon, Chairman
Chief, Electrical Safety Division

Thomas Barkand
Electrical Engineer, Mine Electrical Systems Division

Nicholas Damiano
Electrical Engineer, Mine Electrical Systems Division

Kevin Dolinar
Electrical Engineer, Electrical Safety Division

Gerald Dransite
Electrical Engineer, Electrical Safety Division

Juliette Hill
Mining Engineer, Quality Assurance and Material Testing Division

Patrick Retzer
Electrical Engineer, Electrical Safety Division

Wesley Shumaker, P.E.
Mechanical Engineer, Applied Engineering Division



TABLE OF CONTENTS

1	INTRODUCTION.....	1
2	GENERAL INFORMATION	1
2.1	THE MINE.....	1
2.2	THE TEST AREA AND TEST DESCRIPTIONS	2
2.2.1	<i>Track Entry Description</i>	<i>2</i>
2.2.2	<i>Through-The-Earth Testing Locations.....</i>	<i>4</i>
2.2.3	<i>Belt Entry Description</i>	<i>5</i>
2.2.4	<i>Track Entry Test</i>	<i>5</i>
2.2.5	<i>Belt Entry Test</i>	<i>6</i>
2.2.6	<i>Crosscut Test</i>	<i>6</i>
2.2.7	<i>Stopping Penetration Test.....</i>	<i>6</i>
2.2.8	<i>S-Turn Test</i>	<i>6</i>
2.2.9	<i>Parallel Entry Test.....</i>	<i>6</i>
2.2.10	<i>Through-The-Earth Test</i>	<i>6</i>
2.2.11	<i>Base Stations.....</i>	<i>7</i>
2.2.12	<i>Distance Measurements</i>	<i>7</i>
3	SUMMARY OF RESULTS.....	7
4	DETAILED TEST RESULTS (ORDERED BY TEST DATE)	10
4.1	RAJANT BREADCRUMB™ SYSTEM	10
4.1.1	<i>System Description</i>	<i>10</i>
4.1.2	<i>Track Entry Test</i>	<i>11</i>
4.1.3	<i>Belt Entry Test</i>	<i>12</i>
4.1.4	<i>Crosscut Test</i>	<i>12</i>
4.1.5	<i>Parallel Entry Test.....</i>	<i>12</i>
4.2	CONCURRENT TECHNOLOGIES CORPORATION / TIME DOMAIN ULTRA-WIDE BAND.....	13
4.2.1	<i>System Description</i>	<i>13</i>
4.2.2	<i>Track Entry Test</i>	<i>14</i>
4.2.3	<i>Belt Entry Test</i>	<i>15</i>
4.2.4	<i>Crosscut Test</i>	<i>15</i>
4.2.5	<i>Stopping Penetration Test.....</i>	<i>16</i>
4.2.6	<i>Parallel Entry Test.....</i>	<i>16</i>
4.2.7	<i>S-Turn Test</i>	<i>16</i>
4.2.8	<i>Tracking Demonstration.....</i>	<i>17</i>
4.3	GAMMA SERVICES, INC.	17
4.3.1	<i>System Description</i>	<i>17</i>
4.3.2	<i>Track Entry test.....</i>	<i>18</i>
4.3.3	<i>Parallel Entry Test.....</i>	<i>19</i>
4.3.4	<i>Through-the-Earth Testing</i>	<i>19</i>
4.4	INNOVATIVE WIRELESS TECHNOLOGIES AXON NODE SYSTEM	19
4.4.1	<i>System Description</i>	<i>19</i>
4.4.2	<i>Track Entry Test</i>	<i>20</i>
4.4.3	<i>Belt Entry Test</i>	<i>21</i>
4.4.4	<i>Stopping Penetration Test.....</i>	<i>21</i>
4.4.5	<i>S-Turn Test</i>	<i>21</i>
4.4.6	<i>Parallel Entry Test.....</i>	<i>22</i>
4.4.7	<i>Tracking Demonstration.....</i>	<i>22</i>
4.5	KUTTA CONSULTING SUBTERRANEAN WIRELESS ELECTRONIC COMMUNICATION SYSTEM (SWECS).....	23
4.5.1	<i>System Description</i>	<i>23</i>
4.5.2	<i>Track Entry Test</i>	<i>23</i>
4.5.3	<i>Through-The-Earth Test</i>	<i>24</i>
4.6	TRANSTEK TELEMAG THROUGH-THE-EARTH COMMUNICATION SYSTEM	25
4.6.1	<i>System Description</i>	<i>25</i>
4.6.2	<i>Through-The-Earth Test.....</i>	<i>26</i>
5	ADDENDUM – KUTTA CONSULTING TESTS AT ENLOW FORK MINE.....	27

TABLE OF FIGURES

Figure 1: Map of Test Area in McElroy Mine.....	2
Figure 2: Track Entry.....	3
Figure 3: Track Entry Sketch – Not To Scale.....	3
Figure 4: Belt Entry	5
Figure 5: Rajant Breadcrumb™ Nodes.....	11
Figure 6: Rajant Track and Belt Entry Tests	12
Figure 7: Rajant Parallel Entry Test.....	13
Figure 8: CTC/Time Domain Ultra-Wide Band Radio.....	14
Figure 9: CTC/Time Domain Track and Belt Entry Tests.....	14
Figure 10: CTC/Time Domain Track Entry Test (Voice Only)	15
Figure 11: CTC/Time Domain Parallel Entry Tests	16
Figure 12: CTC/Time Domain S-Turn Test.....	17
Figure 13: (L to R) Master Field Generator, Receiver, and Personal Alarm Device	18
Figure 14: Gamma Services Track Entry Test.....	18
Figure 15: Gamma Services Track Entry Test; Base Station Past Dip Area	18
Figure 16: Gamma Services Parallel Entry Test.....	19
Figure 17: Gamma Services Through-The-Earth Test.....	19
Figure 18: Innovative Wireless Technologies AXON node.....	20
Figure 19: Innovative Wireless Technologies Track and Belt Entry Tests	21
Figure 20: Innovative Wireless Technologies Track Entry Test; Base Station Past Dip	21
Figure 21: Innovative Wireless Technologies S-Turn Test.....	22
Figure 22: Innovative Wireless Technologies Parallel Entry Test	22
Figure 23: Kutta Consulting SWECS	23
Figure 24: Kutta Consulting Track Entry Test	24
Figure 25: Kutta Consulting Through-The-Earth Test @ ~270'.....	24
Figure 26: Kutta Consulting Through-The-Earth Test @ ~600'.....	25
Figure 27: Transtek Telemag Unit; Underground and Surface @ 270'	26
Figure 28: Transtek Through-The-Earth Test @ ~600'	26
Figure 29: Transtek Through-The-Earth Test @ ~270'	27

1 Introduction

The Mine Safety and Health Administration formed a committee to evaluate communication and tracking system technology that could be adapted for use in underground mines. This effort was in response to the recent Sago and Alma mine accidents which indicated that functioning communication and tracking systems would benefit search and rescue efforts.

MSHA solicited input from the public through its website for technology that could be applied in the underground mine environment to improve communications or provide personnel tracking ability. To date, MSHA has received more than 100 proposals in response to the solicitation. At the time the committee reviewed the proposals and selected six systems for further evaluation, approximately 25 proposals had been submitted. The systems selected represent a cross-section of different technologies proposed including wireless mesh networks; ultra-wide band radio; and very low frequency through-the-earth. The systems selected feature the capability to provide either two-way voice communications and/or tracking, do not depend on wired communication, and were ready to test at the time the selection was made. CONSOL Energy, Inc. offered to assist in the evaluation of these technologies by providing the McElroy Mine in which to test the systems.

The purpose of the underground field tests was to evaluate how well the signals propagate; how much overburden through-the-earth systems could penetrate; how interference affected system performance; and to determine the accuracy of tracking systems.

This report details the results of the field tests.

2 General Information

2.1 The Mine

McElroy Coal Company operates the McElroy Coal Mine, ID 46-01437, in Marshall County, West Virginia. CONSOL Energy Inc., the controller of McElroy Coal Company, offered the McElroy Mine as a test site for MSHA's testing of communications and tracking systems. In-mine testing of six communications and/or tracking systems was conducted between March 28 and April 27, 2006 at the McElroy Mine.

McElroy Mine produces bituminous coal in the Pittsburgh seam with two longwall and several continuous miner sections. Over 700 people are employed at this mine, which produced over 10,400,000 tons of coal in 2005.

2.2 The Test Area and Test Descriptions

CONSOL designated the area of the mine between the Fish Creek and Conner's Run Portals for testing. The Fish Creek Portal consists of both a shaft with an elevator and a slope for mine access. The shop and supply yard are located at this portal. The mine's coal preparation plant is located at the Conner's Run Portal. A conveyor belt transports coal to the preparation plant through a slope at this portal.

The main test area consisted of three entries between these two portals: the track entry, the conveyor belt entry, and the return air entry.

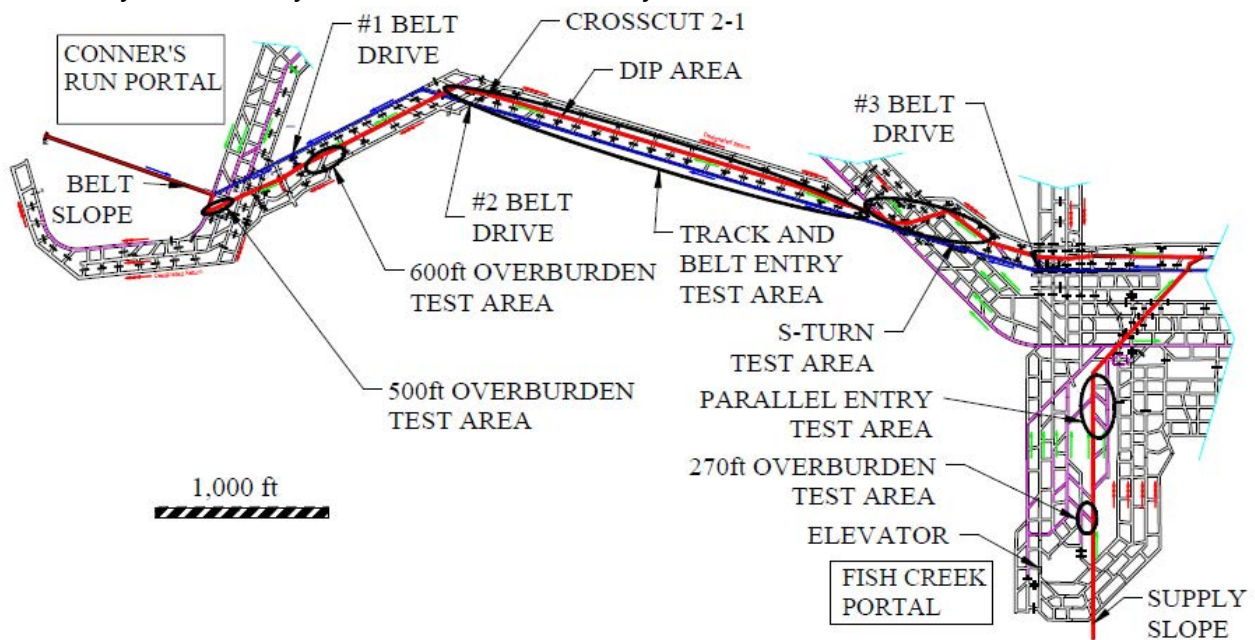

Figure 1: Map of Test Area in McElroy Mine

2.2.1 Track Entry Description

The track entry is also referred to as the #2 entry. The track entry from the #2 belt drive to the S-turn test area was measured to be 18 ft wide and 6 ft high on average (note: S-turn area had an uneven roof as high as 30 ft or more). There was a 2,500-ft section of the entry which led to entries forming an S-turn (over a length of 1,000 ft) on the Fish Creek Portal side. There is metal stopping material in this curve area. The S-turn has an uneven roof-rib due to the fact it intersects a portion of old mine works. There are also pumps, metal jack posts, and other miscellaneous equipment present. True line of sight could not be maintained in the track entry test area due to elevation changes and slight turns. The other end of the entry formed a 120° angle with a 1,600-ft length of entry, which approached the bottom of the Conner's Run Portal slope.

There was a dip in the entry approximately 450 ft from crosscut 2-1 in the area of crosscut 2-6 towards the Fish Creek Portal. The dip area dropped at least ten ft in elevation from crosscut 2-1 and caused the loss of line of sight. Neutral air flowed through the entry. There were several areas of roof spalling and rib sloughage.



Figure 2: Track Entry

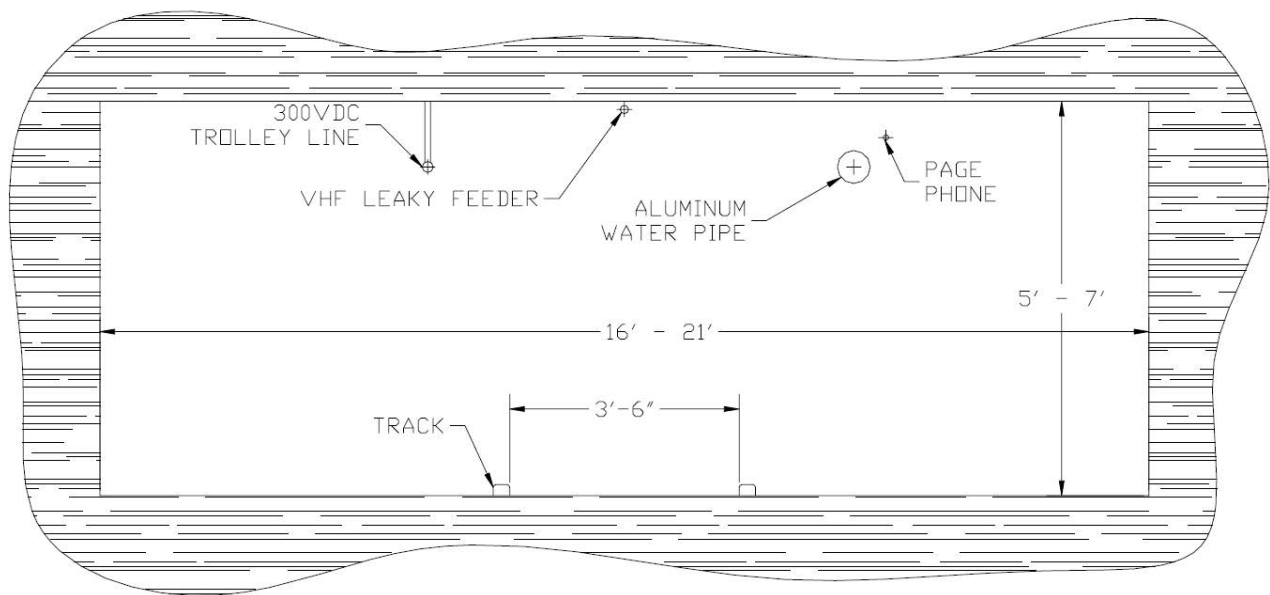

Figure 3: Track Entry Sketch - Not To Scale

The following list comprises the mine infrastructure and potential sources of interference located in the track entry:

- track
- 300 V dc trolley wire
- VHF leaky feeder communication system
- high voltage ac transmission cables
- mine page phones and cables
- roof bolts, straps, and wire mesh for roof control
- aluminum water line

- the #2 belt drive was located at the end of the 2,500-ft length of entry on the Conner's Run Portal side of the test area
- the #3 belt drive was located at the end of the 2,500-ft length of entry on the Fish Creek Portal side of the test area

2.2.2 Through-The-Earth Testing Locations

The surface locations for through-the-earth tests were selected based upon the availability of favorable surface topography. Points on the surface with corresponding overburden depths of 270ft, 500ft, and 600 ft, nominal, were identified and staked by a survey crew prior to conducting tests. All other surface locations that corresponded to the underground test area were either under water or on steep, wooded hillsides that offered no easy access.

The point of 270ft overburden was located on the edge of the gated supply yard of the Fish Creek Portal. This location was adjacent to a small power sub-station and had power lines running overhead.

The point of 500ft overburden was located near a haul road within 1,200ft (straight line distance) of a large power sub-station and had power lines running overhead. This location was on the Conner's Run Portal side of the test area.

The point of 600ft overburden was located in an open field also on the Conner's Run Portal side of the test area. The large power sub-station was within 900ft (straight line distance) of this area. Power lines were not directly overhead but were within 500ft.

During testing it was found that all surface locations were in areas of high electrical noise that caused interference to the communication systems being tested. No exact measurements of the interference levels were taken but by observation of the test equipment, the point of 270ft overburden offered the least amount of interference and the point of 500ft of overburden offered the most.

The underground locations for the through-the-earth tests corresponded to the locations chosen based upon surface availability.

The point of 270ft overburden was located at the bottom of the Fish Creek Portal slope. This location had extensive metal wire mesh installed on the mine roof and coal ribs in addition to the other mine infrastructure described in the Track Entry Description section.

The points of 500ft and 600ft overburden were located in the track entry on the Conner's Run Portal side of the test area. These areas are as described in the Track Entry Description section. The wire mesh was not as extensive as was at the 270ft location.

2.2.3 Belt Entry Description

The belt entry is also referred to as the #1 entry. The belt entry was measured to be approximately 16 ft wide and 6 ft high on average (note: Belt drive area had a roof cut as high as 30 ft). The belt entry in which tests were conducted ran parallel to the previously described 2,500 ft section of track entry. True line of sight could not be maintained throughout the belt entry test area because of elevation changes in the entry and the presence of belt line structures.

Intake air traveled through the entry. There were several areas of roof spalling, and rib sloughage was more prominent in this entry.



Figure 4: Belt Entry

The following list comprises the mine infrastructure and potential sources of interference located in the belt entry:

- conveyor belt and belt structure with control lines and switches
- wire mesh belt guards
- high voltage ac cables
- mine page phones and lines
- CO monitoring system
- roof bolts, straps, and wire mesh for roof control
- the #2 belt drive was located at the end of the 2,500-ft length of entry on the Conner's Run Portal side of the test area
- the #3 belt drive was located at the end of the 2,500-ft length of entry on the Fish Creek Portal side of the test area

2.2.4 Track Entry Test

Testing starts at crosscut 2-1. A base station is established with a stationary crew and the necessary equipment. A mobile crew with respective equipment would walk towards the Fish Creek Portal. The mobile crew could record events as they would move down the entry, through the dip, and into the "S" turn area. If at any time the signal was lost, the mobile crew would move back towards the base station until communications were reestablished and record that spot as the maximum range of that particular test. The purpose of this test is to determine the maximum propagation of a signal in the track entry.

2.2.5 Belt Entry Test

This test is conducted in the belt entry. Testing starts with a stationary crew near the #2 belt drive at crosscut 2-1. A base station is established with the stationary crew and the respective equipment. A mobile crew and equipment would then move towards the Fish Creek Portal. The mobile crew could record events as they would move down the belt entry on either side of the belt. If at any time the signal was lost, the mobile crew would move back towards the base station until communications were reestablished. They could then record that reestablished spot as the maximum range of the particular test. The purpose of this test is to determine the maximum propagation of a signal in the belt entry.

2.2.6 Crosscut Test

This test is conducted in the track entry. The mobile crew would move around a corner, usually a 90 degree turn, into a crosscut until they lost signal. They would record both the distance into the crosscut and the distance from the base station to the crosscut. The purpose of this test is to determine the maximum propagation of a signal around a corner.

2.2.7 Stopping Penetration Test

The base station and mobile unit are positioned in an area such that they are separated by two concrete block stoppings. The purpose of this test is to determine the ability of the system to maintain communication through these obstructions.

2.2.8 S-Turn Test

Testing is in the track entry. A base station is established with a stationary crew and the necessary equipment. A mobile crew with respective equipment would walk through the S-turn area of the track entry. The purpose of this test is to determine how well a signal negotiates the difficult geometry of the S-turn.

2.2.9 Parallel Entry Test

Testing is in the track entry. A base station is established with a stationary crew and the necessary equipment. A mobile crew with respective equipment would walk through a crosscut into an adjacent track entry, move towards the Fish Creek Portal past two blocks and then return to the initial track entry. This test is an extension of the Crosscut Test.

2.2.10 Through-The-Earth Test

This test is for systems capable of sending information through the earth. A base station is established at survey points on the surface with a surface crew and necessary

equipment. A second base station is established at corresponding points underground with an underground crew and necessary equipment. Attempts are then made to establish communication between the two crews. Some systems transmit a beacon signal from underground. In this circumstance, the surface crew makes attempts to receive the beacon signal.

2.2.11 Base Stations

Base stations where a stationary component of the communication or tracking system was located were established during in-mine testing at several different points depending on the test being conducted.

During Track Entry and Crosscut Tests, the base station was established in the track entry at crosscut 2-1. A power center and the #2 belt drive were located at this crosscut on the belt entry side of the intersection. Because there was a significant change in elevation from crosscut 2-1 to crosscut 2-6, a base station was established on the Fish Creek Portal side of this dip area during some Track Entry Tests in order to avoid severe changes in entry geometry.

During Belt Entry Tests, stationary units were located on the Fish Creek Portal side of belt drive #2 at different locations that are individually noted on the test result map included with each detailed test result.

During Parallel Entry Tests, the base station was located in the track entry at the intersection of the slope track and the Fish Creek Portal track.

During S-turn Tests, the base station was located in the track entry as individually noted on the test result map included with each detailed test result.

During through-the-earth testing, only three different overburden depths were attempted due to either surface or underground location limitations. The available depths were approximately 270 ft, 500 ft, and 600 ft. These locations are individually located on test result maps included with each detailed test result.

2.2.12 Distance Measurements

Distances in the track entry were measured with either a Rolatape measuring wheel (1ft increments) or Hilti laser range meter. Distances in the belt entry were estimated based on information from the mine map.

3 Summary of Results

MSHA evaluated and performed field testing of six (6) communication and/or tracking systems. All but one system that was tested were prototypes and are not currently commercially available. The systems operated using one of the following technologies (in no particular order):

- medium frequency radio (<3 MHz)
- ultra-wide band radio
- very low frequency (<10kHz), through-the-earth
- wireless mesh network (IEEE 802.11b or 802.15.4 standards)

Field testing was conducted to determine:

- how well signals propagate (maximum distance between nodes)
- how much overburden systems can penetrate if capable of through-the-earth communication
- mine coverage area (i.e. are there blind spots and why?)
- accuracy of tracking features
- if interference would be an issue

The testing that was conducted resulted in the following observations (Note that some results are specific to this test area in this mine. Propagation distances may be longer or shorter at other mine sites depending on differences in entry geometry and mine infrastructure):

Medium Frequency Radios

1. The signal from a medium frequency radio system was found to couple onto existing metallic mine infrastructure and could propagate more than one mile.
2. Systems that use medium frequencies have the potential to provide two-way voice and data communications.
3. Other communication systems and electrical systems already installed in the mine did produce some level of interference, but the effects could be mitigated by using correct filtering and signal amplification.
4. Further study is needed to determine what types of conductors propagate the signal most effectively.
 - * Separate tests conducted by CONSOL Energy, Inc. at their Enlow Fork Mine on June 1, 2006 resulted in voice communication at a range of more than two miles. This range was limited by the track entry length. The only conductors present in the last 300ft of the track entry test area were the mine page phone line, the carbon monoxide monitoring system line, and a twisted pair phone line.

Ultra-Wide Band (UWB) Radio

1. In this test area, range was approximately 1,200ft with uninterrupted reception and approximately 2,000ft with some dead spots. The signals produced do not turn corners well; therefore system design must address how to provide coverage in adjacent entries.
2. UWB systems have the potential to provide two-way voice communications and tracking to within 20ft or better accuracy, as well as data transmission.
3. In order to outfit the sample test area with communications using ultra-wide band systems, access points would have to be installed in each entry at distances of a maximum of every 2,000ft. Redundancy would also have to be engineered

to ensure that the system would continue to function in the event of an explosion or fire.

4. Interference from other communication systems and electrical systems already installed in the mine did not seem to be an issue. The factors that governed signal propagation distance could be attributed to entry geometry in the case of the track entry and both entry geometry and the presence of an abundance of metallic structures in the belt entry.

Very Low Frequency, Through-The-Earth

1. Through-the-earth (TTE) voice communication signals could penetrate overburden of 270 ft and a beacon signal could be received from underground.
2. None of the TTE systems tested could verify receiving a signal (voice or beacon) through more than 270 ft of overburden.
3. Based upon published literature and theoretical calculations, receiving signals at depths greater than 270ft may be possible.
4. Other communication systems, electrical systems, and/or other infrastructure already installed at the mine site did produce some level of interference.
5. Off-axis tests demonstrated that the signal could be received when the underground and surface units were not directly in line with each other.
6. Further study and system development is needed to achieve greater depths and mitigate the effects of interference.
 - * Separate tests conducted by CONSOL Energy, Inc. at their Enlow Fork Mine on May 31, 2006 resulted in two-way text communication at depths of 558ft and 631ft. One-way text communication was received underground from the surface at a depth of 900ft. At the 558ft and 631ft locations, reception speed was 20-30 characters per minute with some lost (~20%) characters. At the 900ft location, text speed was 2-3 characters per minute with many lost (>50%) characters. The system under test was a proof of concept and had no error correction built into the software.

Wireless Mesh Networks

1. Wireless mesh network type systems that utilize 802.11b protocol at 2.4 GHz propagated up to 1,500 ft in this test area. The signals produced do not turn corners well; therefore system design must address how to provide coverage in adjacent entries.
2. Wireless mesh network type systems that utilize 802.15.4 protocol at 900 MHz propagated up to 1,800 ft in this test area. The signals produced do not turn corners well; therefore system design must address how to provide coverage in adjacent entries.
3. Wireless mesh networks have the potential to provide two-way voice communications and tracking to the nearest node, as well as data transmission.
4. In order to outfit the sample test area with communications using wireless mesh network systems, access points would have to be installed in each entry at distances of a maximum of every 1,500 to 1,800 ft. Redundancy would also have to be engineered to ensure that the system would continue to function in the event of an explosion or fire.
5. Interference from other communication systems and electrical systems already installed in the mine did not seem to be an issue. The factors that governed

signal propagation distance could be attributed to entry geometry in the case of the track entry and both entry geometry and the presence of an abundance of metallic structures in the belt entry.

Summary Table of Test Results

Manufacturer	Technology	Data/Voice	Voice Quality	Range Track Entry Through Dip Area	Range Track Entry No Dip Area	Range Belt Entry	Depth Through The Earth
Rajant	802.11b 2.4 GHz	D,V	Cell Phone	500 ft Node	1,471 ft Node 1,493 ft Voice	600 ft Voice	N/A
CTC/Time Domain	Ultra-Wide Band	D,V	Cell Phone	2,000 ft Node 1,382 ft Voice	1,679 ft Voice	450 ft Node	N/A
Gamma Services	Very Low Frequency (<10kHz)TTE 900 MHz Tag	D	N/A	700 ft Tag	1,012 ft Tag	Not Performed	270ft Beacon
Innovative Wireless Technologies	802.15.4 900 MHz	D	N/A	1,067 ft 10dBm 1,800 ft 20dBm	1,490 ft 10dBm	230 ft 10dBm	N/A
Kutta Consulting	Medium Frequencies Very Low Frequency (<10kHz)TTE	D,V	Cell Phone	5,387 ft Voice (not maximum)		3,058 ft Voice (base in track) (not maximum)	270ft Beacon
Transtek	Very Low Frequency (<10kHz)TTE	V	CB Radio	Not Performed	Not Performed	Not Performed	270ft Voice
Kutta Consulting during CONSOL's Enlow Fork Testing	Medium Frequencies Very Low Frequency (<10kHz)TTE	D,V Text Only TTE	Cell Phone	N/A	Approx. 11,600 ft Voice (not maximum)	Approx. 9,000 ft Voice	558ft and 631ft two-way Text 900ft one-way Text (S to UG)

4 Detailed Test Results (Ordered by Test Date)

4.1 Rajant Breadcrumb™ System

Test Date: March 28, 2006

4.1.1 System Description

Rajant has developed hardware known as its Breadcrumb™ system that allows the deployment of a fully wireless LAN using the 802.11b protocol, known as WiFi, at 2.4

GHz. This is an ad-hoc mesh network and all nodes are portable and can operate on battery power. Voice communication for this test was through the use of a PDA and laptop PC running Voice Over IP software. Software running on a laptop PC that was connected to the base station node also provided signal strength information. For node to node communication tests, maximum range was exceeded when the signal strength fell below a usable level. Maximum range was then recorded as the distance associated with the point of last usable signal strength. In addition, each node had an LED to indicate whether or not successful network connectivity has been established. Maximum range of the PDA was exceeded when voice or text reception was lost. Maximum range was then recorded as the distance associated with the last successful voice or text communication.



Figure 5: Rajant BreadCrumb™ Nodes

4.1.2 Track Entry Test

The base station node and a laptop computer were set up near crosscut 2-1 in the track entry. A mobile node was taken down the track entry and lost communication with the base node as it moved through the dip in the track entry (@~500ft from base station). This mobile node was then placed in the dip area 434 ft from the base node. A second mobile node was taken down the track entry away from the first mobile node that was placed in the dip at 434 ft. At a point 1,378 ft from the first mobile node positioned in the dip area communication was established at 11 Mbps. At a point 1,471 ft from the first mobile node positioned in the dip area communication was reduced to 1 Mbps.

This test was repeated with a handheld PDA communicating with the first mobile node positioned at the point 434 ft from the base node. At a point 1,493 ft from the first mobile node positioned in the dip area, voice communication between the PDA and the first mobile node was lost.

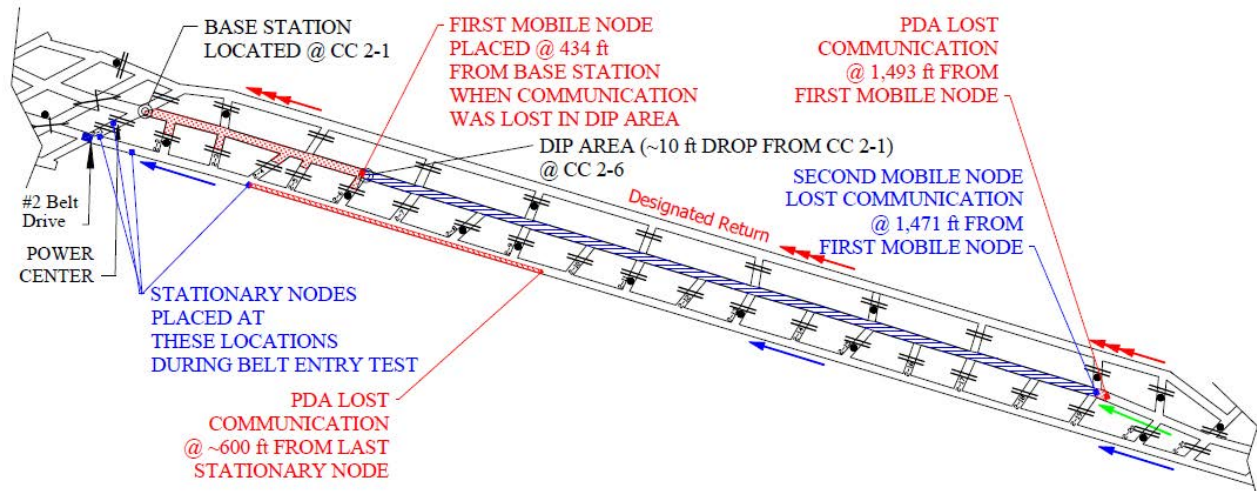

Figure 6: Rajant Track and Belt Entry Tests

4.1.3 Belt Entry Test

Stationary nodes were placed at four positions starting at crosscut 2-1 and the last being placed in the walkway on the off-side of the belt entry at crosscut 2-4. This was done in order to leave the laptop computer at crosscut 2-1 and to demonstrate the transmission of data through several nodes. A PDA was then taken down the belt entry using text messages to communicate (text was only used because voice was not audible when the belt was running; when text was received, voice could have been received). Communication between the last stationary node and the PDA was lost midway between crosscut 2-9 and 2-10; a distance of ~ 600 ft.

4.1.4 Crosscut Test

The crosscut test was conducted using the base node and the PDA. The base node was in the track entry at crosscut 2-1. The PDA was taken down the track entry and into 5 successive crosscuts. At the first crosscut (50 ft away from the base node), communication was established 31 ft into the crosscut. This distance was limited by a stopping. At the second crosscut (150 ft away from the base node), communication was established 47 ft into the crosscut. This distance was limited by a stopping. At the third crosscut (276 ft away from the base node), communication was established 42 ft into the crosscut. This distance was limited by a stopping. At the fourth crosscut (323 ft away from the base node), communication was established 28 ft into the crosscut. This distance was not limited by a stopping. At the fifth crosscut (430 ft away from the base node), communication was established 33 ft into the crosscut. This distance was limited by a stopping. The PDA was taken through a steel door in this stopping toward the belt entry but communication was lost immediately on the other side of the stopping with the door open.

4.1.5 Parallel Entry Test

The parallel entry test was conducted between the base node and the PDA in an area of the mine where there was access to two parallel entries with three clear crosscuts (except for a power center in the first crosscut). The PDA was taken into the first

crosscut and communication was established into the intersection of the second entry, approximately 70 ft through the crosscut. Communication was lost when the PDA was carried down the second entry towards the middle crosscut.

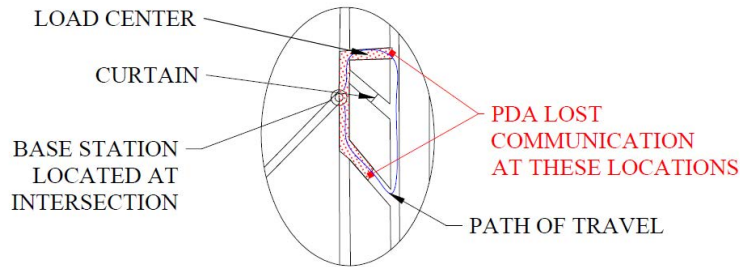

Figure 7: Rajant Parallel Entry Test

4.2 Concurrent Technologies Corporation / Time Domain Ultra-Wide Band

Test Date: March 30 and 31, 2006

4.2.1 System Description

The Concurrent Technologies Corporation/Time Domain system is a pulse position modulated Ultra-Wide Band (UWB) radio system with a center frequency of 5.3 GHz and a total bandwidth of 4.2 GHz (from 3.1 GHz to 7.3 GHz) capable of transmitting data, voice, and calculating range from radio to radio using time of flight of the signal. The transmit power of the radios was set at FCC limited power +10 db for this testing. Proprietary software (the Ranging Analysis Module) running on a laptop PC that was connected to a test radio provided range information and signal strength information. For node to node communication tests, maximum range was exceeded when the signal strength fell below a usable level. Maximum range was then recorded as the distance associated with the point of last usable signal strength. For voice communication, a set of radios was modified specifically for this test to run Voice Over IP software. Maximum range during voice communication tests was exceeded when voice reception was lost. Maximum range was then recorded as the distance associated with the last successful voice communication.

Several waveform scans were taken during the various tests to show how the signal changed in different conditions. A spectrum analyzer was also used to monitor and record any background noise present in the test areas.



Figure 8: CTC/Time Domain Ultra-Wide Band Radio

4.2.2 Track Entry Test

The base node and a laptop computer were set up at the base station. A mobile node was taken down the track entry while running the Ranging Analysis Module software that is able to calculate range from the base node to the mobile node as well as display signal strength information. The UWB radios demonstrated uninterrupted reception out to 1,200 ft, and a maximum range of approximately 2,000 ft with some dead spots. Both of these ranges were achieved through the dip area. Omni-directional antennas were used out to a range of 950ft and then a directional antenna was installed on the base station radio. Although not included in this test system, Time Domain stated that in a final design voice could be received at any point that range data is available.

The range information provided by the UWB radios was compared to the distance as measured by the Rolatape wheel. It was found that the two measurements were within 10 ft of each other out to 1,000 ft and within 21 ft of each other between 1,000 ft and 2,000 ft.

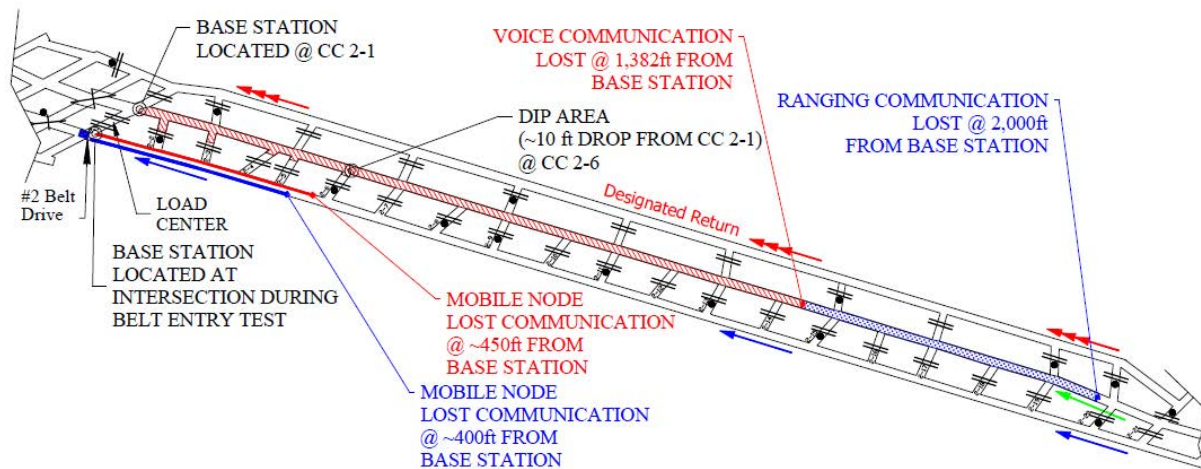

Figure 9: CTC/Time Domain Track and Belt Entry Tests

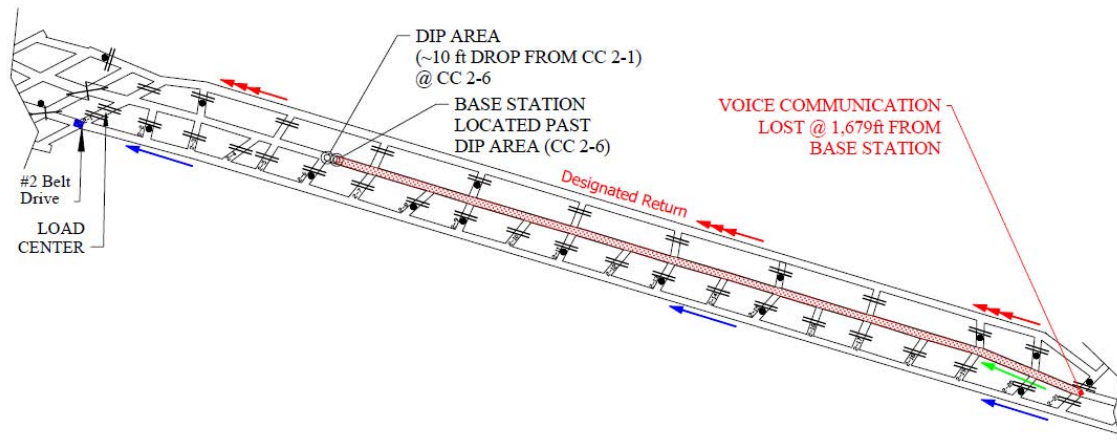

Figure 10: CTC/Time Domain Track Entry Test (Voice Only)

This test was repeated but with voice communication combined with ranging. Both the base station and the mobile unit used directional antennas. Voice communication was established through the dip area to a range of 1,382 ft.

The voice communication test was repeated on the second day of testing with the base node set up past the dip area in the track entry. The ranging feature was turned off since it requires more bandwidth to perform both ranging and communication at the same time. Communication was established to a range of 1,679 ft. However, at 1,566 ft dead spots were noticed that required moving the mobile unit to various points in the entry to acquire a signal. Directional antennas were used on both units for this test.

4.2.3 Belt Entry Test

The base station node and laptop computer were placed at the belt drive located at crosscut 2-1 with a directional antenna facing down the belt entry (toward the fish Creek Portal). A mobile node with a directional antenna was taken down the belt entry on the walkway side of the entry. Range measurements were taken with the Ranging Analysis Module software as the mobile node was moved. The maximum range reached was 450 ft before the signal was lost. The mobile node was then taken down the belt entry using the walkway on the opposite side of the entry (the off-side of the belt). The maximum range reached was 400 ft before the signal was lost.

4.2.4 Crosscut Test

The crosscut test was conducted between the base station and the mobile node while running the Ranging Analysis Module software. Directional antennas were used on both the base station and the mobile node. At the first crosscut (58 ft away from the base station), communication was established 31 ft into the crosscut. This distance was limited by a stopping. At the second crosscut (172 ft away from the base station), communication was established 37 ft into the crosscut measured from the nearest rail. This distance was not limited by a stopping. At three subsequent crosscuts (over a total

distance of approximately 430 ft from the base station), communication could be established approximately 10 ft in as measured from the nearest rail.

4.2.5 Stopping Penetration Test

The stopping penetration test was conducted between the base station and the mobile node while running the Ranging Analysis Module software. Directional antennas were used on both the base station and the mobile node. Good communication was established between the two nodes through two stoppings spaced approximately 100 ft apart.

4.2.6 Parallel Entry Test

The parallel entry test was conducted between the base station and the mobile node while running the Ranging Analysis Module software. Directional antennas were used on both the base station and the mobile node. The mobile node was taken into the first crosscut and communication was established into the intersection of the second entry, approximately 70 ft through the crosscut. When the mobile node was taken down the second entry, communication was lost until it neared the intersection of the middle crosscut, at which point communication was reestablished. Communication was lost again as the mobile node was taken beyond this intersection. Communication was reestablished as the mobile node neared the intersection of the last crosscut.

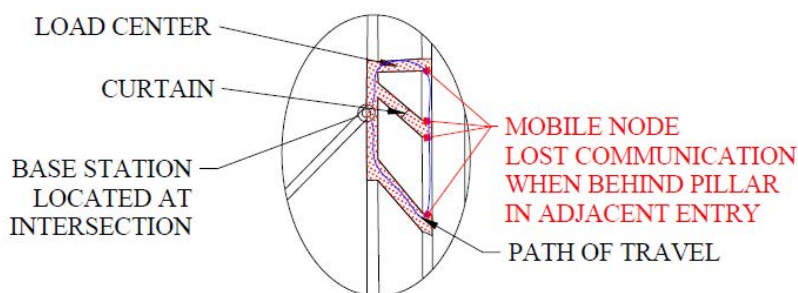

Figure 11: CTC/Time Domain Parallel Entry Tests

4.2.7 S-Turn Test

A test was conducted to determine how the signal propagated through the S-turn section of the track entry. Directional antennas were used on both the base station and the mobile node. The base station was set up approximately 150 ft before the entrance to the curve area. The mobile node was taken into the curve area where the signal was maintained through two turns in the entry before being lost at a range of 384 ft.

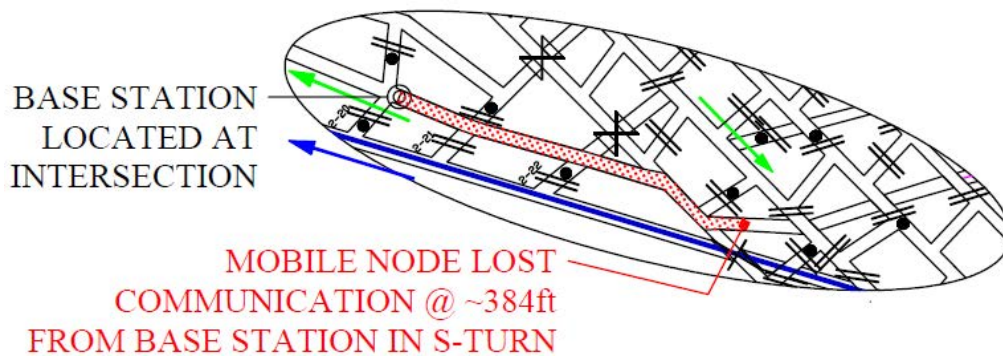

Figure 12: CTC/Time Domain S-Turn Test

4.2.8 Tracking Demonstration

Proprietary tracking system software from Time Domain was demonstrated. Five stationary nodes were placed along a 500 ft stretch of the track entry. A mobile node was carried down the entry past the stationary nodes. A graphical interface on the laptop depicted the stationary nodes and showed the position of the mobile node relative to the stationary nodes as it was moved. No distance measurements were taken during the tracking demonstration. However, all of the stationary and mobile nodes were visible during the demonstration and the graphical interface correctly depicted the location of the mobile node in relation to the stationary nodes (i.e. midway between stationary node x and stationary node y, or, right next to node z).

4.3 *Gamma Services, Inc.*

Test Date: April 4, 2006

4.3.1 System Description

This system provides checkpoint-type tracking using the Master Field Generator (MFG) and Personal Alarm Device (PAD) developed for use with the Gamma Services' proximity protection system. Each miner would carry a PAD with a unique ID number. The PAD will send its ID to the MFG using a 900MHz signal and then the MFG will send all of the PAD IDs within range through the earth to a surface located receiver using Very Low Frequency signals. During in-mine testing, a laptop was connected to the MFG with software that could display the ID number received from the PAD. Maximum range was exceeded when the ID number from the PAD was no longer received. Maximum range was then recorded as the distance associated with the point of last reception. During through the earth testing, the MFG was used to send a pulsed beacon signal from underground. Testing was successful when a receiver on the surface indicated reception of the pulsed signal.

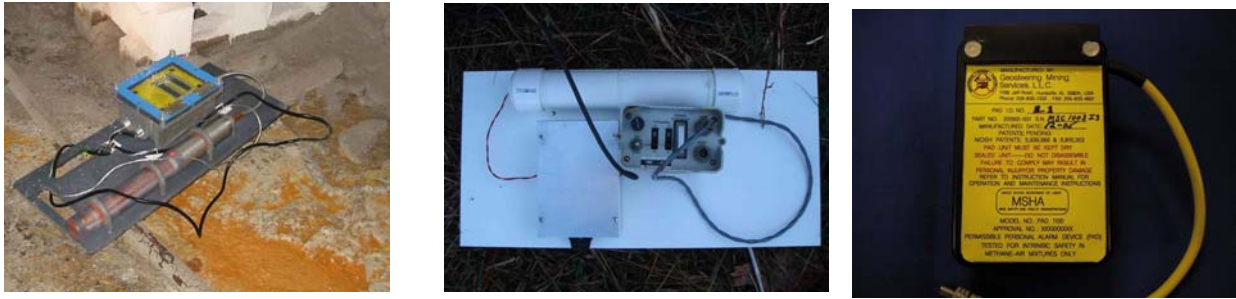

Figure 13: (L to R) Master Field Generator, Receiver, and Personal Alarm Device

4.3.2 Track Entry test

The signal from the PAD was received at a distance of 700 ft from the base station when going through the dip area. Once the base station was moved to the Fish Creek Portal side of the dip, the PAD signal was maintained through a distance of 1,012 ft.

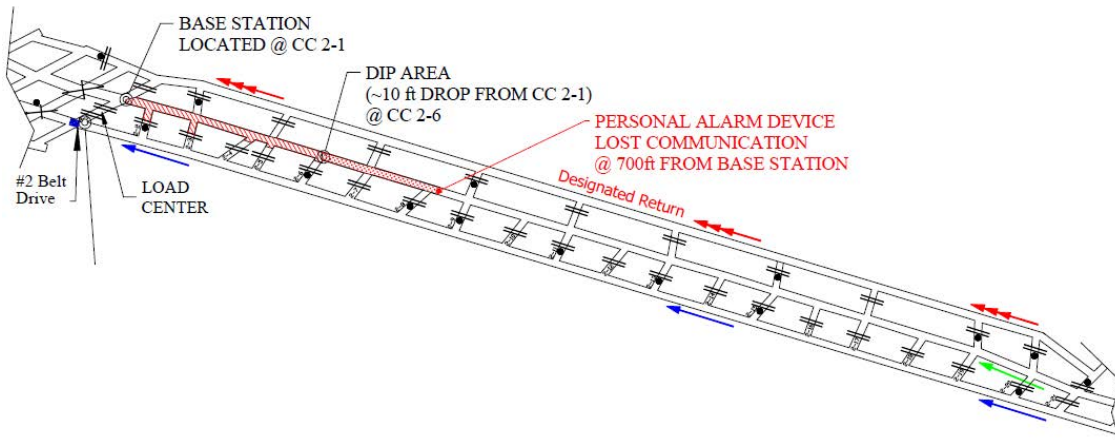

Figure 14: Gamma Services Track Entry Test

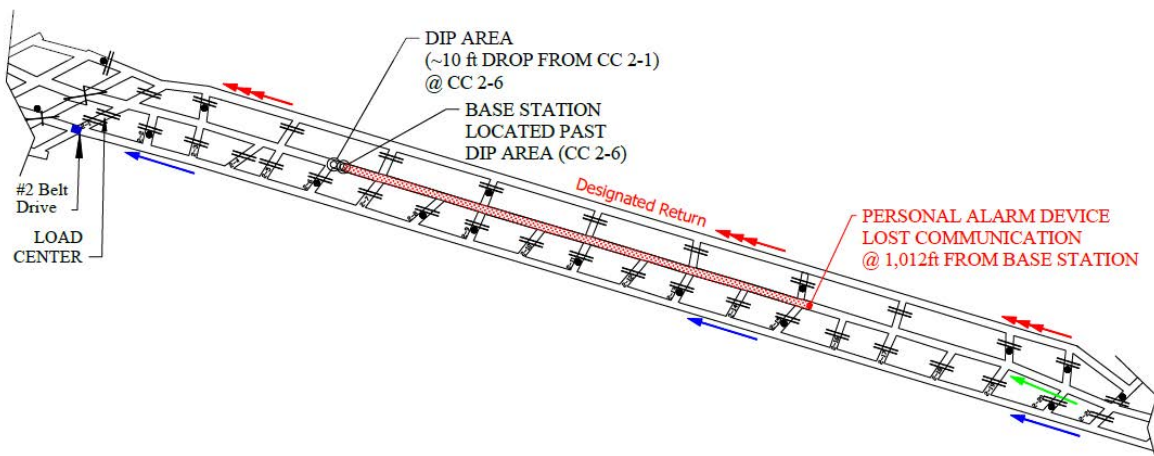

Figure 15: Gamma Services Track Entry Test; Base Station Past Dip Area

4.3.3 Parallel Entry Test

The parallel entry test demonstrated that the signal from the Personal Alarm Device was lost after making two 90 degree turns.

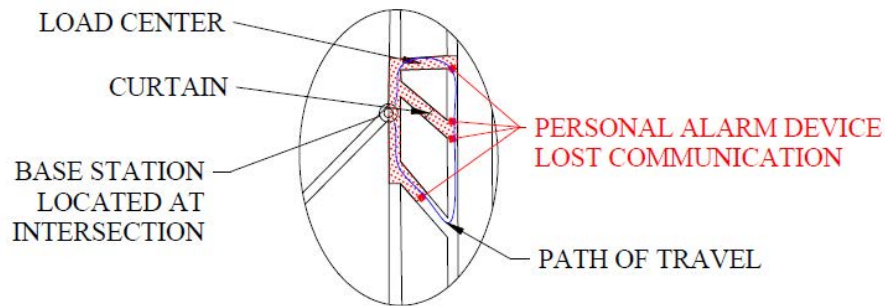

Figure 16: Gamma Services Parallel Entry Test

4.3.4 Through-the-Earth Testing

The MFG was setup at the bottom of Fish Creek Portal's slope entry with approximately 270 ft of overburden. The underground signal was successfully detected using a receiver at that location.

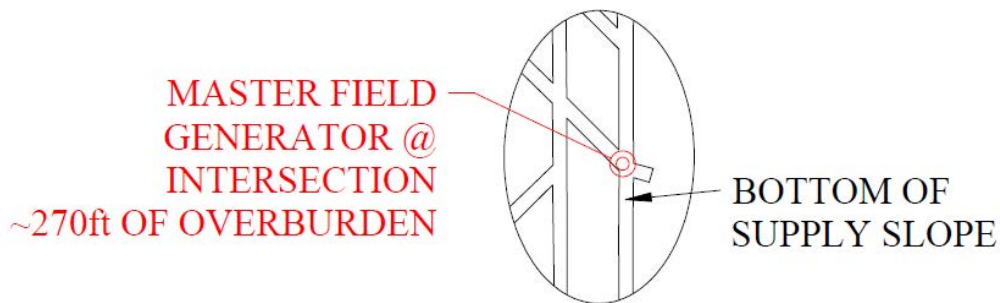

Figure 17: Gamma Services Through-The-Earth Test

The system was then moved underground to a location of approximately 500 ft of overburden and the signal was unable to be detected by the surface located receiver. A possible hardware failure by the receiver was experienced at 500 ft and was later confirmed when the receiver and MFG were placed in close proximity to each other.

4.4 Innovative Wireless Technologies AXON Node System

Test Date: April 10 and 11, 2006

4.4.1 System Description

The AXON module from Innovative Wireless is a transceiver module that is designed to work to IEEE 802.15.4 specifications. Several modules are deployed to form an ad-hoc mesh network. The AXON module as tested is capable of both wireless data transmission and real-time tracking based on signal strength; voice and text capabilities are planned. The nodes are designed to run both Zigbee™ and Synaptrix™, which is an Innovative Wireless proprietary mesh-networking software stack. Two versions of the 900MHz module were used during these tests; a 10 dBm version and a higher power 20

dBm version. The base station module was connected to a laptop PC running a Graphical User Interface that was used to display node position. Link quality was determined by sending 100 data packets between nodes. While no voice or text communication was able to be performed in this testing, Innovative Wireless had previously determined the link quality required for these modes of communication. Confirmed reception of at least 90 packets was required to establish voice communication while confirmed reception of at least 50 packets was required to send text messages. Maximum range was recorded as the distance associated with the point at which only 50/100 packets were being received. Each node also included LEDs that indicated packet reception and signal strength. Antennas on these modules were omnidirectional.

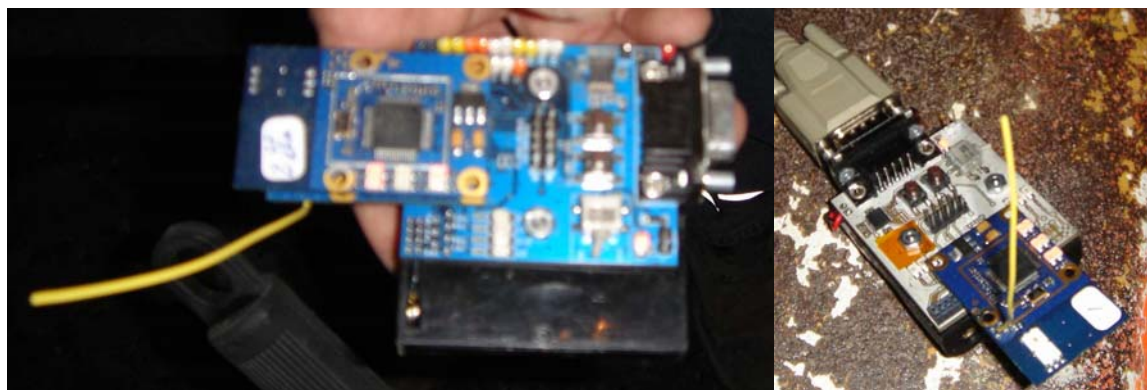

Figure 18: Innovative Wireless Technologies AXON node

4.4.2 Track Entry Test

Using the standard power (10 dBm) module, node to node communication was established in the track entry to a distance of 1,067 ft through the dip area. A stationary node was then placed in the dip area at a distance of 450 ft from the base station node, and a third node was taken down the track entry. Node-to-node communication was successful up to a distance of 1,490 ft from the node positioned at 450 ft from the base station.

Using two high power (20dBm) AXON modules, node to node communication was established in the track entry to a distance of 1,800 ft through the dip area. The nodes were then placed on the ground to test communication when the antennas were in a less than favorable position. Limited communication was established at a distance of 800 ft between nodes, with good communication established at a distance of 500 ft.

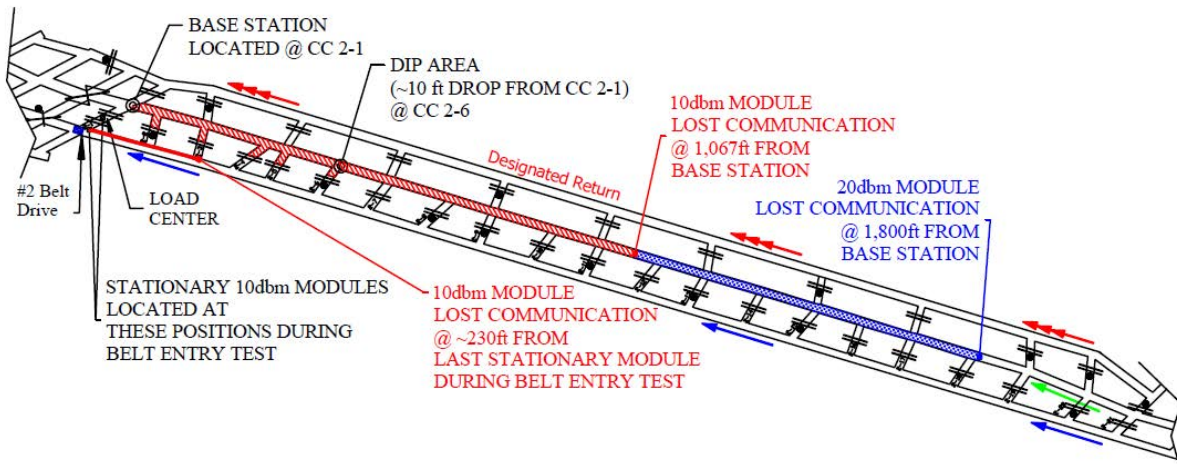

Figure 19: Innovative Wireless Technologies Track and Belt Entry Tests

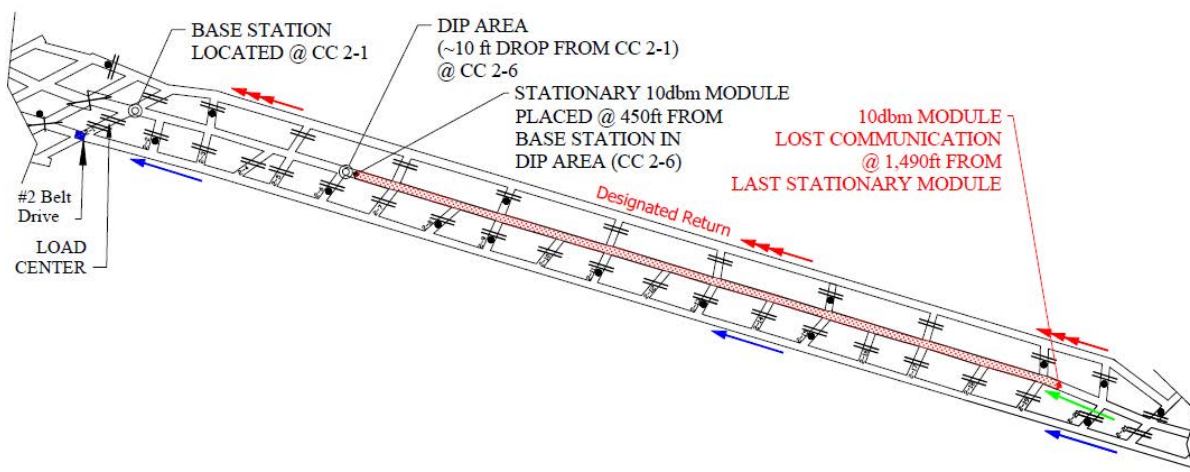

Figure 20: Innovative Wireless Technologies Track Entry Test; Base Station Past Dip

4.4.3 Belt Entry Test

The standard power nodes were taken into the belt entry where node to node communication was established to a distance of approximately 230 ft.

4.4.4 Stopping Penetration Test

Good communication (99/100 packets) could be established through two stoppings located approximately 100 ft apart.

4.4.5 S-Turn Test

Four nodes were required to propagate a signal through the S-turn section of the track entry. One node was located at the beginning of the section, two nodes were spaced apart in the middle, and one node was located at the end of the 1,000 ft section.

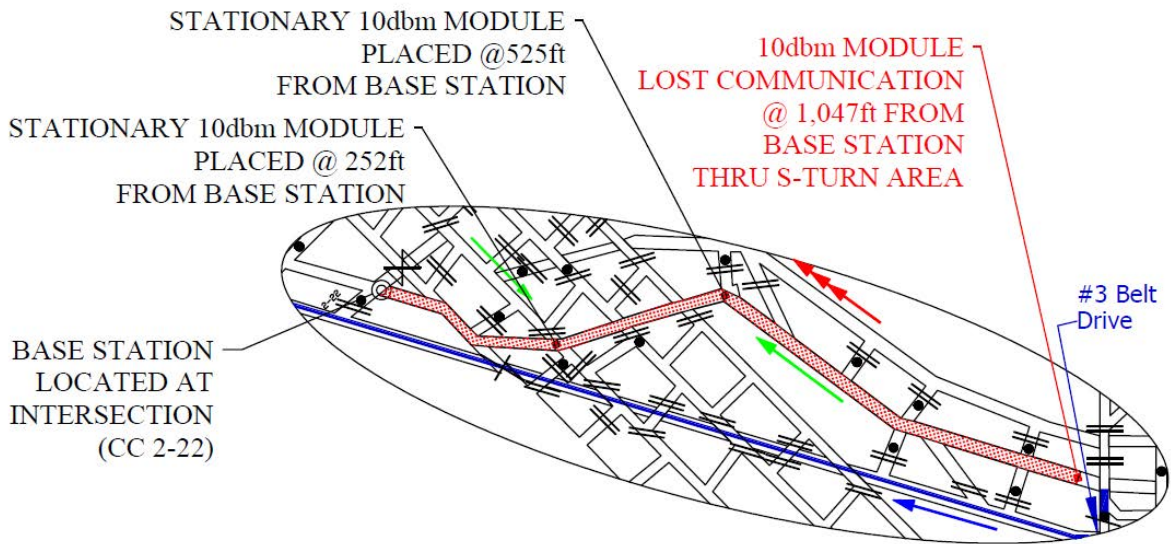

Figure 21: Innovative Wireless Technologies S-Turn Test

4.4.6 Parallel Entry Test

Communication could be established when turning one crosscut corner but not two.

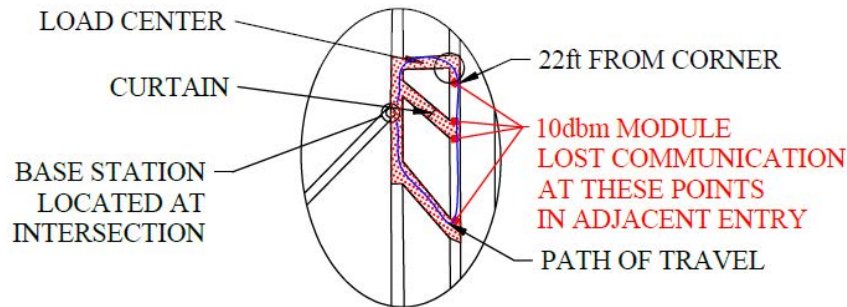

Figure 22: Innovative Wireless Technologies Parallel Entry Test

4.4.7 Tracking Demonstration

A tracking demonstration was conducted to show the ability of the system to track a mobile node using signal strength. A computer (placed near the base station node) was used to display the relative position of a mobile node as it was moved between stationary nodes. Four nodes were positioned at different points along a 2,100 ft stretch of the track entry. Exact tracking down to "X" number of ft cannot be determined accurately since the tracking is done using signal strength. The only thing that can be determined is what nodes the person is between at a given time. For example, one person could be 100 ft around a corner from a node and appear to be very far away (weak signal strength) to the system. On the other hand, a person could be 1,000 ft line-of-sight from another node and appear much closer (because 1,000 ft line-of-sight has better signal strength). However, the system can store information on where the fixed nodes were placed and using this information can determine approximate locations with an accuracy of the distance between any two fixed nodes (i.e. If the two fixed nodes are 500 ft apart and show a person between, then we know where that individual is within a 500-ft radius).

4.5 *Kutta Consulting Subterranean Wireless Electronic Communication System (SWECS)*

Test Date: April 24 and 25, 2006

4.5.1 System Description

The SWECS is a two-way voice and data communication system being developed for the U.S. Army under a Small Business Innovative Research contract. Voice and data are transmitted between radios using Medium Frequencies (<3 MHz). Three different frequencies were tried during this testing as well as both loop and ferrite rod antennas (both of these antenna types are directional). Also tested was a radiolocation beacon that operated at Very Low Frequency (<10kHz) and sent a continuous tone. During in-mine testing, maximum range was exceeded when voice communication between radios was lost. Maximum range was then recorded as the distance associated with the point of last voice communication. Through the earth testing would have been successful if voice communication was established between the two SWECS radios. Through the earth testing of the radiolocation beacon was successful when the beacon tone could be heard through a receiver located on the surface.



Figure 23: Kutta Consulting SWECS

4.5.2 Track Entry Test

All underground testing was done using the Kutta medium frequency radios. The two radios were first tested from point to point underground. The base station was set up at crosscut 2-1 in the track entry and the mobile unit was taken toward the Fish Creek Portal in the track entry. The test was conducted using both a loop antenna (~1.5 meter diameter) and a ferrite rod antenna. Good voice communication was established at a distance of 5,387 ft between units and at that point the testing team with the mobile unit stopped walking. This test was then repeated at two other medium frequencies with both loop antennas and ferrite rod antennas. Good voice communication was established at the 5,387 ft location at both frequencies with both antennas and, as with the first test, the testing team with the mobile unit did not continue further down the track entry at that point.

At a distance of 5,387 ft from the base station, the mobile unit was taken into the belt entry while the base station remained in the track entry at crosscut 2-1. Voice communication was lost on the belt entry side of the stopping. At a distance of 3,058 ft

from the base station, the mobile unit was again taken into the belt entry where voice communication continued uninterrupted.

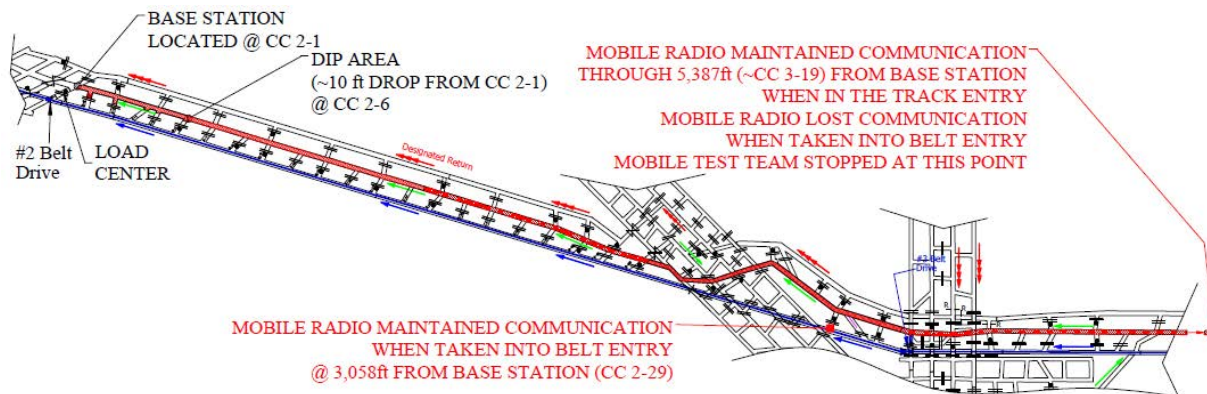

Figure 24: Kutta Consulting Track Entry Test

4.5.3 Through-The-Earth Test

The system was set up at the bottom of Fish Creek Portal's slope entry with approximately 270 ft of overburden. The system was unable to receive voice communication either underground or on the surface. However, it was later discovered that an incorrect setting was used on the underground radio. A beacon was then transmitted from underground. The beacon was detected on the surface but some 50 to 100 ft away from the known surveyed point on the surface.

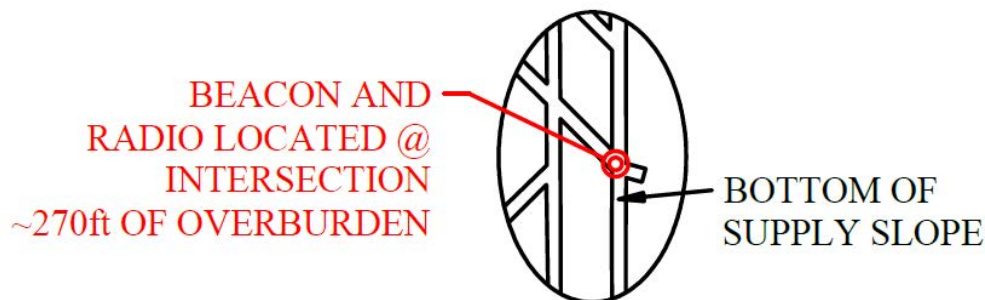

Figure 25: Kutta Consulting Through-The-Earth Test @ ~270'

The system was then moved to a location of approximately 500 ft of overburden. Initially an attempt was made to receive the beacon signal at this location but it could not be definitively detected. Because of the high amount of electrical interference detected during the beacon test, it was decided to not attempt a voice communication test in this area.

The system was then moved to a location of approximately 600 ft of overburden. No beacon signal or voice communication could be established at this location.

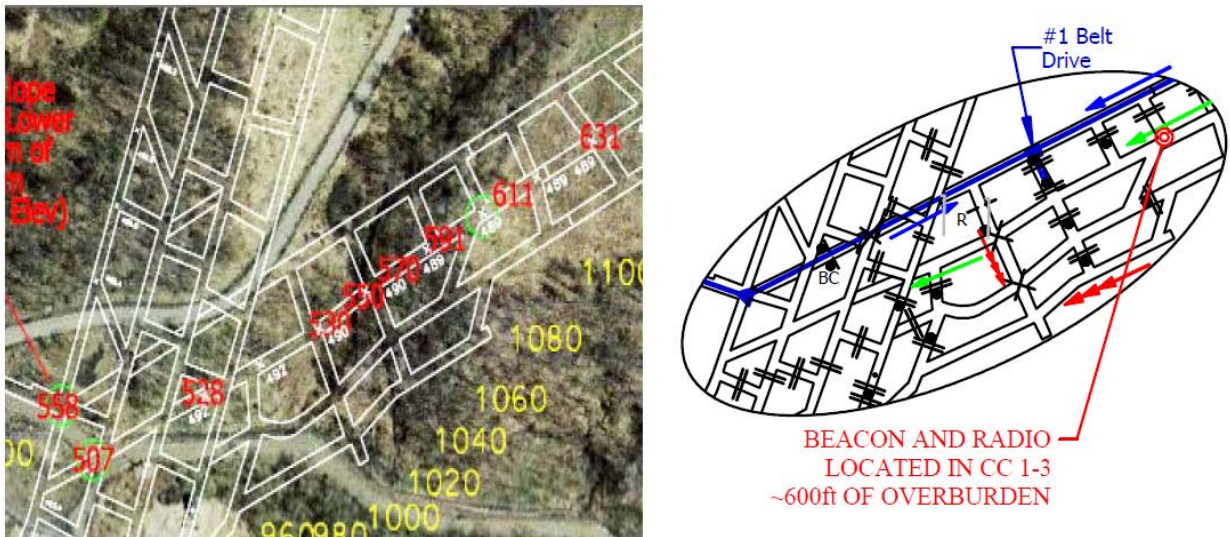

Figure 26: Kutta Consulting Through-The-Earth Test @ ~600'

4.6 *Transtek Telemag Through-The-Earth Communication System*

Test Date: April 26 and 27, 2006

4.6.1 System Description

The Telemag through-the-earth voice communication system consists of two transceiver units with loop antennas (antennas are directional). Each transceiver unit is equipped with two individual loop antennas. One loop antenna is used for receiving and the other loop antenna is used for transmitting. The transceivers use single side band modulation with comb filters to attenuate noise from 60 Hz power sources. The transmission system is half-duplex which allows communications in both directions, but only one direction at a time (not simultaneously). This system operates in the Very Low Frequency range between 3,000 and 8,000 Hz. This radio frequency range readily propagates through the earth.

One transceiver unit and antenna is located in the underground mine and the other transceiver unit antenna is positioned on the surface directly over the corresponding underground loop antenna. The system does not have signal locating capabilities so the surface and underground positions must be known before the communication system is set up. Once communication is established, the surface antenna can be repositioned for optimal signal quality. Through-the-earth testing was successful when voice communication was established between the two radios.



Figure 27: Transtek Telemag Unit; Underground and Surface @ 270'

4.6.2 Through-The-Earth Test

The first test location was at approximately 600 feet of overburden. This point was chosen first because of the favorable surface topography needed to deploy the 360 ft. circumference (115 ft diameter) loop antennas and minimal haulage traffic at both the surface and the underground locations.

Neither the underground nor the surface unit was able to receive communication signals at this location.

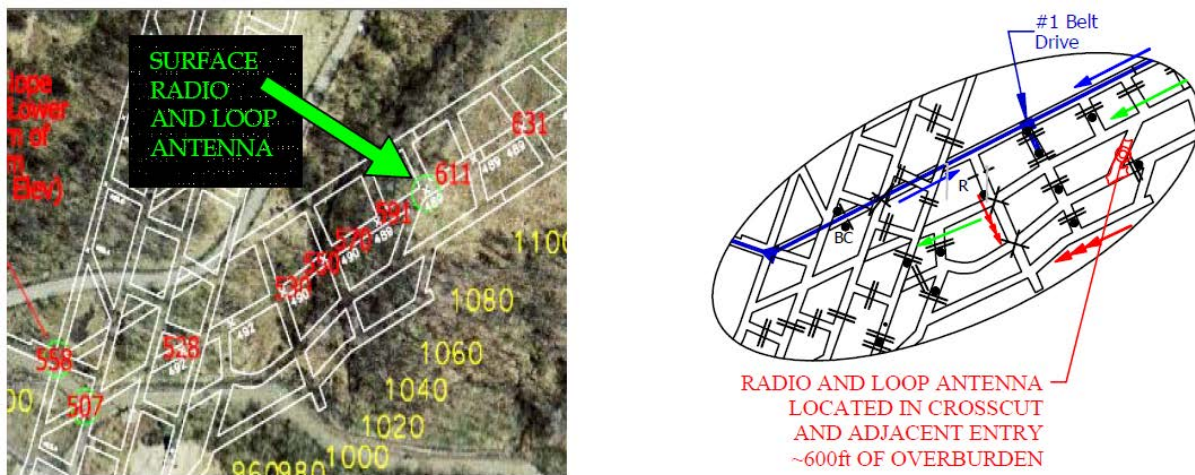

Figure 28: Transtek Through-The-Earth Test @ ~600'

Testing resumed the following day with modified transceivers and reconfigured 180 ft circumference (approximately 60 ft diameter) loop antennas. This reconfigured system was designed to operate through shallower overburdens. This redesigned system was previously demonstrated at a different mine site to be capable of establishing two-way voice communications through an overburden of 280 ft.

A location near the bottom of the slope at Fish Creek Portal that had approximately 270 feet of overburden was selected for testing. The underground test location had extensive metal wire mesh installed on the mine roof and coal ribs. Both surface and underground units successfully established clear two-way voice communications at this location. The underground unit and antenna was then moved off the track into an

adjacent entry approximately 170 feet away for an off-axis test. Voice communication was received underground from the surface unit, but the surface unit was unable to receive any underground transmission during this test.

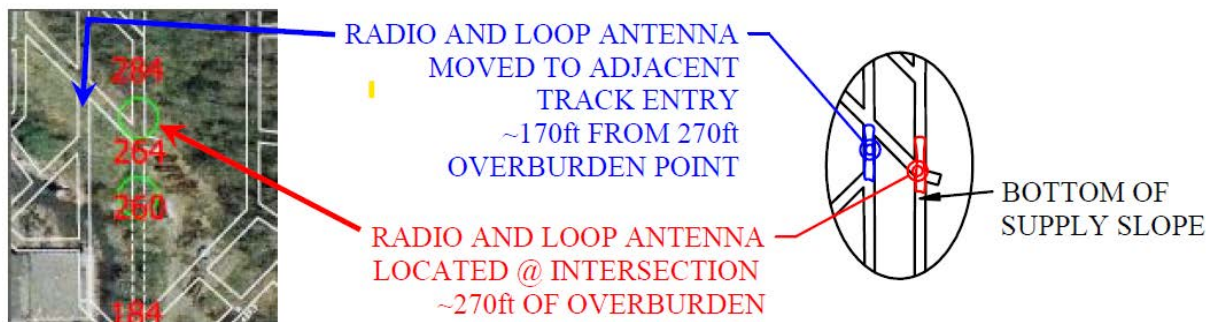

Figure 29: Transtek Through-The-Earth Test @ ~270'

5 Addendum – Kutta Consulting Tests at Enlow Fork Mine

Test Dates: May 31, 2006 and June 1, 2006

Additional tests of two Kutta Consulting communication systems were performed by CONSOL Energy, Inc. at their Enlow Fork Mine in West Finley, PA. MSHA was invited to observe these tests.

The first system tested was a proof of concept through the earth text messaging system developed since Kutta's last field test at the end of April. The system consisted of a transceiver, an associated loop antenna, and a laptop PC located at both the underground position and the surface position. Several Ultra Low Frequencies were tested at locations with associated depths of approximately 580 ft, 631 ft, and 900 ft. Two different developmental software packages were used that enabled text to be sent at different data rates and allowed different methods of data modulation.

At both 580 ft and 631 ft, text was successfully received at both underground and surface locations at speeds of approximately 2-3 characters per minute and 20-30 characters per minute. The software package did not contain any error correction features; therefore, text messages were not always complete and did contain erroneous characters. It was estimated that 20% of the characters on average were incorrect or lost.

At a depth of approximately 900 ft, only the slow mode (2-3 characters per minute) of text transmission was attempted and resulted in reception of a text message underground only. It is speculated that electrical noise at the surface location interfered with signal reception. This surface location also had a steep slope associated with it that would not allow the surface antenna to be spread out into a perfectly flat circle, therefore diminishing the strength and quality of the signal both received and sent. It was estimated that 50% of the characters on average were incorrect or lost.

The second system was the Kutta medium frequency radio tested previously at McElroy Mine and described in section 4.5. Some changes to the radio software had been made but radios were essentially the same as when tested at McElroy Mine. The main focus was to test at longer distances and in an intake escapeway free of conductors. Enlow Fork Mine offered a relatively straight stretch of track, belt, and intake escapeway entries along a longwall section. Conductive structures in the track entry included track, aluminum water pipe, trolley line, 7,200VAC cable, twisted pair mine phone line, page phone line, and CO monitoring system line.

The base station radio was set up at the start of the track entry while the mobile radio was taken inby to the end of the track entry (approximately 11,600 ft away). Intermediate stops were made to ensure that voice communication could still be established. Voice communication was established throughout this full range in the track entry. The track entry contained only a twisted pair mine phone line, page phone line, and CO monitoring system line for the last 300 ft. Therefore, it can be concluded that the medium frequency signal will propagate well on at least one of these types of conductors.

Both the base station and the mobile radio were then taken into the belt entry while 11,600 ft away from each other. Initially, the belt was off and weak communication was established. When the belt started up, it was possible to tell that someone was trying to communicate, but clear voice communication could not be established. The mobile unit was then taken outby to a point that was approximately 9,000 ft away from the base station. With both units in the belt entry, clear voice communication was established.

Both the mobile radio and base station were then taken into the intake escapeway at range of approximately 9,000 ft. No conductors were in the escapeway and voice communication could not be established. The mobile unit was then moved outby to a range of approximately 2,000 ft in the escapeway. No voice communication could be established at this point. The mobile unit was then taken outby to a range of approximately 900 ft in the escapeway. Weak voice communication was established but the handheld UHF radios carried by mine personnel performed better than the medium frequency radios. Testing in the escapeway was concluded at this point.

An attempt was made to demonstrate the ability of the Kutta radio to be reconfigured to communicate with the leaky feeder system installed at the mine. While transmissions from the leaky feeder could be received by the Kutta radio, transmissions to the leaky feeder system were unsuccessful.