

SECTION III

2022

Bench Bio Pak

240-R RULES



2022 BENCH BIOPAK 240-R CONTEST RULES

INDEX

Section III

<u>Title</u>	<u>Page</u>
Rules Governing 2022 Bench BioPak 240R Contest and Interpretations of Discount Cards.....	1
Written Examination.....	4
Miscellaneous.....	5
Interpretation of Discount Sheet	6
Visuals/Disassembled.....	8
Tester	10
BioPak 240-R Bench Written Record and Checks	13
Identification of Parts	15

RULES GOVERNING 2022 BENCH BIOPAK 240-R CONTEST AND INTERPRETATIONS OF DISCOUNT CARDS

1. Each participant must be under guard before the start of the Contest in a location assigned by the Chief Judge and must remain continuously under guard until time to work the problem. Information for bench problem design is available on the MSHA website (<https://www.msha.gov>) in the Mine Rescue section under 240R Designers Resources. Participants under guard must be in a location where they will be unable to obtain any information concerning the problem to be worked. Any participant receiving information concerning a Contest problem prior to starting to work the problem will be disqualified by the Chief Judge and the Assistant Chief Judge (no cell phones, iPad, smart watches, etc.). No person, except guards and Contest officials assigned to give the written examination, will be allowed to communicate with any participant under guard. Those who have performed will not be permitted to communicate with any participant awaiting their turn to perform.
2. Any indication of receiving unauthorized information during the working of the problem may result in disqualification as determined by the Chief Judge and the Assistant Chief Judge (no cell phones, iPad, smart watches, etc.). No one except judges, Contest officials and working participants will be permitted in the bench station, unless special approval is given by the Chief Judge. Communication with bench participants, except for the judges, is prohibited. News media and photographers who wish to be in the working area must receive permission from the Director(s) and be accompanied by a Contest official.
3. Any bench participant not in place and ready at the time specified will be disqualified from the Contest.
4. The bench participant will be provided with two BIOPAK 240-R apparatus (one disassembled, one assembled), a test kit, a stopwatch, leak detector fluid, and a tool kit, ~~blank written record and writing device~~. Only the tools and fluid provided will be used for testing and assembly of the apparatus. The problem at the bench station will consist of (1) a visual examination of a disassembled BIOPAK 240-R and the proper assembly and preparation for use in rescue work. This will include correcting any predetermined problem(s) so that the apparatus is in proper working order. Simulating of prepacking the carbon dioxide scrubbers and adding ice will be done as part of the visual examination. This visual examination, correcting predetermined problem(s), and proper assembly can be done at any time allowed for working of the problem. (2) Test the assembled BIOPAK 240-R apparatus with a Test Kit, and correct the predetermined/functional problem(s) so that the apparatus is in proper working

condition. Except for removing the face piece storage plug from the breathing hoses, the assembled BIOPAK 240-R apparatus cannot be disassembled to look for problems/ deficiencies, until the apparatus fails a test. When testing is completed on the assembled BIOPAK 240-R apparatus, the hoses shall be removed from the tester, connected to the face piece, and the upper housing installed. This shall be done before the clock is stopped.

5. Spare parts to correct the predetermined problem(s)/ deficiencies will be provided once the bench participant has specifically identified the problem/ deficiency. This will require the participant to point out the exact location of the problem/ deficiency. (Example: High pressure leak in circuit. Participant will identify the location of the leak.)
6. When an unplanned problem/ deficiency is encountered with the apparatus, the participant will be notified by the judges that the deficiency is not part of the problem. The judge will stop the clock, and any time used to correct the deficiency will not be charged to the working time. However, the process of verbal elimination shall not be used by the bench participant to find the predetermined problem(s). If it becomes obvious to the judges that this is occurring, the first offense will result in a warning, the second offense a discount, and the third offense could result in disqualification as determined by the Chief Judge. (Example: Participant verbally identifies a deficiency with every part of the Facemask when only one predetermined problem/ deficiency exists.)
7. The bench participant will not be allowed to bring any materials, written information, or records to the bench station.
8. Tests will be performed in sequence on the assembled BIOPAK 240-R apparatus as outlined in the rules using the standard functional test procedures with the Test kit as outlined in the BIOPAK 240R Benchman Manual D47C091-D UI Revision D. This revision can be found on ~~MSHA's web page under Mine Rescue contest Bench Resources, 240R Statement/ Problem Design~~ Holme's Association website <https://www.holmessafety.org/holmes-mine-rescue-association-rules-and-contest-resources/>.
9. A maximum of 30 minutes will be allowed to complete the problem. The bench judge will inform the participant when he has five minutes remaining to work the problem. At the completion of the problem, the judge(s) and the participant will note the working time of the problem with the official timekeeper. Work done after the clock is stopped will not be recognized. ~~The contestant will be given 1 minute prior to starting the clock to fill in the functional test procedures on the blank written record. The contestant can write out the test or abbreviate. (Example Constant Flow Test or CFT). The judge will stop the contestant if the~~

~~one minute has elapsed and have him start the 30 minute clock, finishing of the functional test procedures on the blank written record will be part of the 30 minutes allowed to complete the problem. There will be a 2 point discount per line if the written record is not filled out, incomplete, wrong information or illegible with a maximum of 12 discounts. After the clock is stopped, the judge will have the contestant sign and date the written record.~~

10. Any bench contestant who intentionally disturbs, breaks or destroys any tester, apparatus or component of the aforementioned items on a bench problem will receive a warning. Manually abusing or intentionally over or under pressurizing the tester substantially will be considered abusing the equipment. The first offense will result in a warning. The judge will stop the clock and inform the contestant that this is their first warning. Judge must state what the warning is for (the keyword is **intentionally**). The second offense will result in a warning, the clock will not be stopped, and a 100 point discount will be given. The third offense will result in the judge stopping the clock, locating the Chief Judge of the bench and determine if the contestant will be disqualified.

A. Written Examination of Bench Participant

1. The written examination shall consist of 20 questions. Ten questions for the written examination will be taken verbatim from the ~~BIO bank~~. ~~The BIO bank will be taken from the~~ BIOPAK 240R Benchman Manual D47C091-D UI Revision D which will be multiple choice with three choices and each blank shall represent a key word with no more than two consecutive blanks per statement. Ten questions will be taken verbatim from identification of parts. Intentional misspelling of words by the test developer will not be allowed. Multiple choice answers with numbers will either be in the form of numbers written out or numerical. Either version is acceptable. "None of the above" is not acceptable as one of the answers. Twenty minutes will be allowed for the written examination.
2. In special circumstances, individual bench participants may be given oral instead of written examinations by at least two judges. Requests for consideration shall be presented to the Director(s) of the Contest at the time of registration.
3. Bench participants will be separated to the extent possible, and every effort will be made to prohibit discussion of questions and answers among the bench participants.

B. Miscellaneous

1. In the event of ties in the Bench Contest, the number of discounts at bench will be the first tie breaker; the number of discounts on written examination will be the second tie breaker; and the official working time at bench in minutes and seconds will be the third tie breaker.
2. The bench participant and trainer will report to a designated location to review and prepare protests within one hour of notification. Twenty minutes will be given to review and prepare written protests. All protests will be considered by the Chief Judge and his/her Assistant and their decision will be binding.
3. If a wireless internet connection is available, the Contest Director(s) may approve an option where the bench participant can review their results electronically. In those cases, the bench participant must provide an email address that will be used for the review on the form provided at registration. The form must be completed and submitted at registration. Contest officials will email the scorecards, written examination, etc. to the email address on record when they are ready for review. The bench participant will have 45 minutes to review the material starting upon the "read receipt" of the email, but no more than two hours from the time it was posted outside the appeals area, and email any protests back to the Contest Officials.
4. Bench participants must be bonafide employees of the mining industry or members of mine rescue teams designated to fulfill the requirements of 30 CFR Part 49. This does not exclude bench participants whose team is not participating at the National Contest or a member of a college mine rescue team.
5. Disputes with regard to the Bench Contest (except discounts), shall be immediately filed with the Director(s). Disputes filed shall be in writing and set forth incidents, times, names source of information and act complained against. Complainant shall remain accessible to the Director(s) until the complaint is resolved. A decision by the Director(s) shall be final.
6. Any similar terminology may be used to describe a part such as; cylinder or bottle, etc.

7. All parts must correspond with the Individual units that are being used for contest purposes only.

Interpretations of Discount Sheet

A. Written Examination

1. For each incorrect statement _____ 1

B. Time

The time will be recorded in minutes and seconds.

C. Competition at Bench

1. Failure to verbally identify each test being conducted _____ 2

Verbally identify each test being performed.

2. Failure to verbally identify each problem/deficiency _____ 5

Failure to verbally identify is also interpreted as failure to find the problem/deficiency.

Failure to find the problem/deficiency is interpreted as failure to correct the problem.

3. Failure to correct each problem/deficiency _____ 5

4. Continuing without correcting the predetermined problem / deficiency _____ 40

Once a bench participant finds a predetermined problem and does not correct it before continuing with the remaining tests, he/she shall receive a 40 point discount for continuing without correcting the problem and a pending five point discount for failing to correct the problem. If all of the remaining tests are properly conducted and passed and the participant returns to the uncorrected problem and corrects it, the pending five point discount will not be assessed. Should the participant continue on from this point and properly conduct all of the remaining tests again, he/she would also have the original 40 point discount for continuing tests removed.

5. Failure to conduct any visual examination or test on the BIOPAK 240-R, each test_____5
6. Failure to tighten connections properly during assembly, each connection_____1

All connections must be tightened on the apparatus and verbally identified as connected or good at the time the connection is tightened. Failure to verbally identify at the time the connection is being tightened will result in a one point discount for each. Zero adjustment of the Mag. Gauge shall be made on the tester prior to connecting the breathing hoses to the tester.

This includes:

- Vent Valve Assembly - connected or good
 - Diaphragm Worm Gear Clamp - connected or good
 - Flow Restrictor - connected or good
 - Breathing Hose Worm Gear Clamps - connected or good
 - Add and Constant Fittings - connected or good
 - Center Section Lid - connected or good
 - Center Section ¼ Turn Pins - connected or good
 - Cylinder connections - connected or good
 - Adapter to - Facemask - connected or good
 - Test fixture connections - connected or good
- Once the zero adjustment on the Mag Gauge has been made, do not readjust setting for balance of tests.

7. Failure to zero the tester_____10
8. Failure to comply with rules not covered in discount sheet, each infraction_____2

If the discount is not listed on the discount sheet, and if it is not covered under one of the approved rules of the Contest, do not improvise a discount to cover the suspected violation.

D. Visuals/Disassembled

1. Failure to conduct a visual examination of the 7 components, all components, sub components, component parts, assembly, sub-assemblies, retest dates are subject to problems/deficiencies. Contestant is required to verbally identify what is in capital bold print letters. The examples listed below for visual examination of the 7 components are a minimum starting point for training purposes.

2. Failure to conduct a proper visual examination of the **UPPER AND LOWER HOUSING/HARNESS** ____2

The visual examination will include an examination of the harness assembly, lower housing, upper housing, external gauge, O2 regulator and RMS.

3. Failure to conduct a visual examination of the **CENTER SECTION ASSEMBLY** ____2

The participant will verbally identify that the diaphragm is being examined for pliability and signs of deterioration. The participant will verbally identify that the O-ring and sealing edges are being examined for signs of damage and lubrication. The participant will verbally identify that the Demand Valve Assembly, PCM and Moisture Pads are being examined for damage.

4. Failure to conduct a visual examination of the **CARBON DIOXIDE SCRUBBERS** ____2

A proper examination includes a visual inspection for defects and damage of carbon dioxide scrubbers, O-rings and Moisture Control Pad. The participant will verbally confirm the expiration date has not expired. If no carbon dioxide scrubbers are provided, adding carbon dioxide scrubbers shall be simulated as part of the visual carbon dioxide scrubbers examination.

5. Failure to conduct a visual examination of the **CENTER SECTION LID ASSEMBLY** ____2

The visual examination will include an examination for defects and damage of the assembly, O-ring seal (lubrication), ice canisters, coolant lids and sealing edges. If no ice canisters are provided, adding ice canisters shall be simulated as part of the visual center section lid assembly examination.

6. Failure to conduct a proper visual examination of the **O2 CYLINDER** ____2

A proper cylinder examination includes a visual inspection of the cylinder. The participant will verbally identify the cylinder pressure on the gauge, the pressure rating on cylinder, the latest hydrostatic test date, and outlet tube O-ring. Participant will inform the judge if the cylinder pressure is less than 1,500 PSI.

7. Failure to conduct a visual examination of the **HOSES** ____ 2

The participant will verbally identify that the hoses are being inspected for pliability and signs of deterioration. Stretching or manipulating the hoses with a massaging action will be part of this examination. The participant will verbally identify that the sealing edges, are being examined for signs of deterioration. (Install Arrows Up) The participant will verbally identify that the Adapter Assembly O-Ring is being inspected for damage and lubrication.

8. Failure to conduct a visual examination of the **FACEMASK** ____2

The visual examination will include an examination of the head strap assembly, mask body, sealing edges, nose cup, the lens/anti-fog insert, speech diaphragms and magnetic wiper.

9. Failure to have Visual Apparatus fully assembled. (Ready for use)____5
Note: Breathing hoses do not need to be in straps on visual apparatus.

E. Tester

1. Failure to conduct a proper constant flow test _____ 2

Remove the constant add line and connect a test flow meter to the center section constant add feed line. Open O2 cylinder valve and observe the test flow meter while holding the test flow meter in a level position. The flow reading on the flow meter should be as outlined on the Flow Test Chart in REV D of the Benchman Manual paragraph 1.8. Participant will verbally state flow reading. If the flow does not meet the requirements of the table below, the flow restrictor will need replacement.

<u>Cylinder Pressure</u>	<u>Elevation & Flow</u>	<u>Elevation & Flow</u>
	0-5280 ft.	+5280 ft.
<u>PSI</u>	<u>LPM</u>	<u>LPM</u>
1500-2000	1.8-2.4	1.9-2.6
2000-3000	1.9-2.5	2.0-2.8

Close the O2 cylinder valve. Remove test flow meter. Reconnect constant add feed line to apparatus. The definition of "Completing the Flow Test" shall be determined when the contestant removes the upper housing cover, attaches the flow meter to the constant flow port and turns the oxygen cylinder ON and VERBALLY states the reading on the flow meter.

2. Failure to conduct a proper Demand Valve Functional test _____ 2

Remove the Facemask storage plug from the front of the Facemask adapter and install the leak test plug onto the Facemask adapter. Attach one end of the test kit rubber tubing to the leak test plug and the other end to the input port of the test kit. Verify that the SCBA has no pressure contained within the breathing chamber by a zero reading on the test kit pressure gauge. Open the oxygen cylinder valve and listen for the sound of gas flowing into the breathing chamber. The sound of oxygen flowing into the breathing chamber shall cease within approximately 1-3 seconds.

3. Failure to conduct a proper Emergency Bypass Functional test _____ 2

Fill the SCBA with oxygen by depressing the emergency bypass one time for no more than 1-2 seconds. The sound of gas flowing into the center section shall be observed. The gas flow shall cease when the bypass valve button is released.

4. Failure to conduct a proper Vent Valve Functional test _____ 2

Observe the test kit gauge while filling the SCBA with oxygen by depressing the emergency bypass in 2-second bursts until the vent valve has opened and closed; it will be at or below 2 inches of water column. Verbally state the final reading. Close O₂ cylinder valve. Vent the pressure from the SCBA and remove rubber tubing and leak test plug.

5. Failure to conduct a proper low pressure leak test _____ 2

Install the leak test plug onto the Facemask adapter and attach one end of the test kit rubber tubing to the leak test plug and the other end to the input port of the test kit. Verify that the SCBA has no pressure contained within the breathing chamber by a zero reading on the test kit pressure gauge. Insert two test keys into the keyholes in the back of the lower housing. Open the oxygen cylinder valve to pressurize the apparatus and tester. Gently depress the bypass valve to increase the reading to approximately 3 to 4 inches water column.

Close the oxygen valve and fully depress the bypass valve. Immediately use the test kit bleed valve to adjust the SCBA pressure to 6-8 inches water column pressure. Allow the SCBA's pressure to stabilize at 6-8 inches water column of pressure. After one minute, the pressure gauge of the test kit shall indicate no less than 0.2-inches water column pressure below the stabilized starting pressure. An increase in pressure of 0.2 inches Water Column or greater on the test kit requires a restart of the one-minute timed test. Vent the pressure from the SCBA and remove rubber tubing, leak test plug, and keys. Replace Facemask adapter plug.

6. Failure to conduct a proper RMS Gauge and TRIM test ____2

While looking at the gauge and TRIM, open the oxygen cylinder valve and listen for the alarm test and observe the gauge and TRIM color sequence. The gauge will reach full pressure (approximately 60 seconds). The alarm and TRIM will go through a startup self-check: Alarm, Red, Green, Blue light sequence, then a flashing green light. Check for stabilization of alarm lights. Verify that the oxygen cylinder pressure gauge and the RMS gauge are within +/- 10%. Verbally state the final reading.

7. Failure to conduct a proper High Pressure Leak test ____2

Open the oxygen cylinder with the storage plug installed; inspect each plumbing connection and Flow Restrictor with Leak-Tec for a minimum of 60 seconds. During the test the contestant must depress the emergency by-pass to properly check the output fitting of the emergency by-pass. Contestant can depress the by-pass to check for leaks on the output side of the by-pass at any time during the 60 second test. The 60 second test begins when Leak-Tec has been applied to the last fitting, during the test additional fluid may be applied as the contestant checks for leaks.

8. Failure to conduct a proper Low Pressure Alarm Functional test ____2

Turn off the oxygen cylinder and allow the BioPak to slowly reduce system pressure. The low alarm must activate between 650-1000 psig and is indicated by a flashing red light and audible alarm. (Verbally state reading) The RMS will automatically power down once the system pressure is dropped below 25 psig. Vent the SCBA of pressure and remove test equipment.

9. Failure to have Test Apparatus fully assembled. (Ready for use) Note: Breathing hoses do not need to be in straps on test apparatus ____5

**BIO-PAK 240-R Bench Written Record and Checks
Judge's Score Card**

1	Constant flow test	-	-
2	Demand Valve Test	-	-
3	Bypass Test	-	-
4	Vent Valve Test	-	-
5	Low Pressure Leak Test	-	-
6	RMS Gauge Trim Test	-	-
7	High Pressure Leak Test	-	-
8	Low Pressure Alarm Test	-	-
	Ready for use	-	-
	Date	-	-
	Serial Number	-	-
	Signature	-	-
	Cylinder Reading	-	-
	-	-	-
	-	-	-
	-	-	-
	-	-	-
	-	-	-
	-	-	-
	-	-	-
	-	-	-
	-	-	-

State reading per Rev N-p 12
 Oxygen Flow stops 1-3 Sec.
 Oxygen Flow no more 1-2 Sec.
 2 Inches of water or less
 Remove Keys prior to test 6 +/- .2"WC
 Cylinder & Chest Gauge +/- 10% State Reading
 Alarm point 650-1000 State Reading

Team	-	-	-
Contestant	-	-	-
-	-	-	-
-	-	-	-

BIO PAK 240R Written Record and Checks

-	-	-	-
-	-	-	-
-	-	-	-
-	-	-	-
-	-	-	-
-	-	-	-
-	-	-	-
-	-	-	-
-	-	-	-
-	-	-	-
-	-	-	-
-	-	-	-
-	-	-	-
-	-	-	-
-	-	-	-
-	-	-	-
-	-	-	-
-	-	-	-
-	-	-	-
-	-	-	-
-	-	-	-
-	-	-	-
-	-	-	-
-	-	-	-
-	-	-	-
-	-	-	-
-	-	-	-
-	-	-	-
-	-	-	-
-	-	-	-
-	-	-	-
-	-	-	-
-	-	-	-

Team - - - -

Contestant - - - -

BioPak 240 Revolution Complete

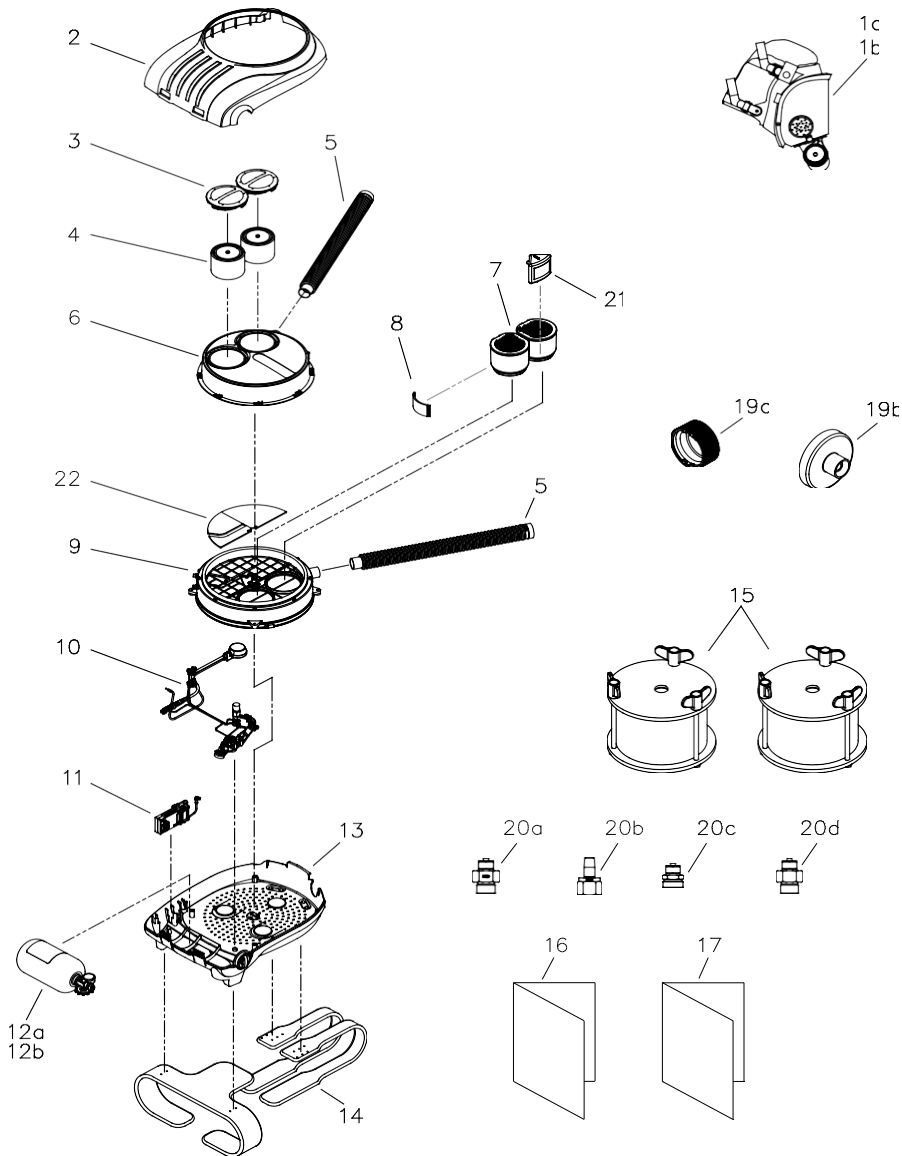

1 Cons. No.	2 Designation	1 Cons. No.	2 Designation
2	Upper Housing Assembly	14	Harness Assembly
3	Coolant Lid	15	Ice Canister Freeze Form
4	Ice Canister	19	Facemask Storage Plug
5	Breathing Hose	21	PCM Heat Exchanger
12	O2 Cylinder	22	Moisture Absorbent Pad Set
13	Lower Housing Assembly		

Lower Housing Assembly

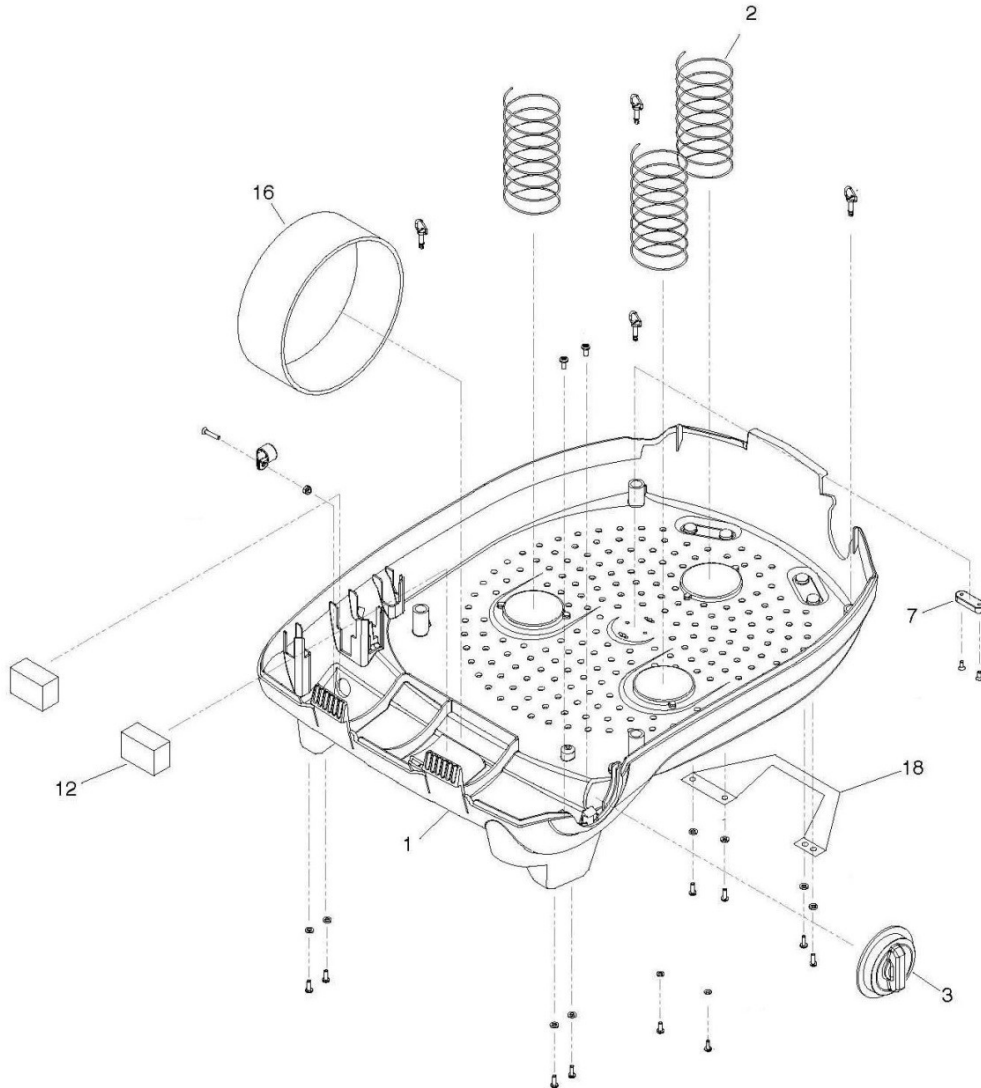

1 Cons. No.	2 Designation	1 Cons. No.	2 Designation
1	Lower Housing Shell	12	Latch Foam Pad
2	Diaphragm Springs	16	Oxygen Cylinder Hold-Down Strap
3	External Oxygen Knob	18	Carrying Handle
7	Vent Spacer		

Pneumatic Assembly

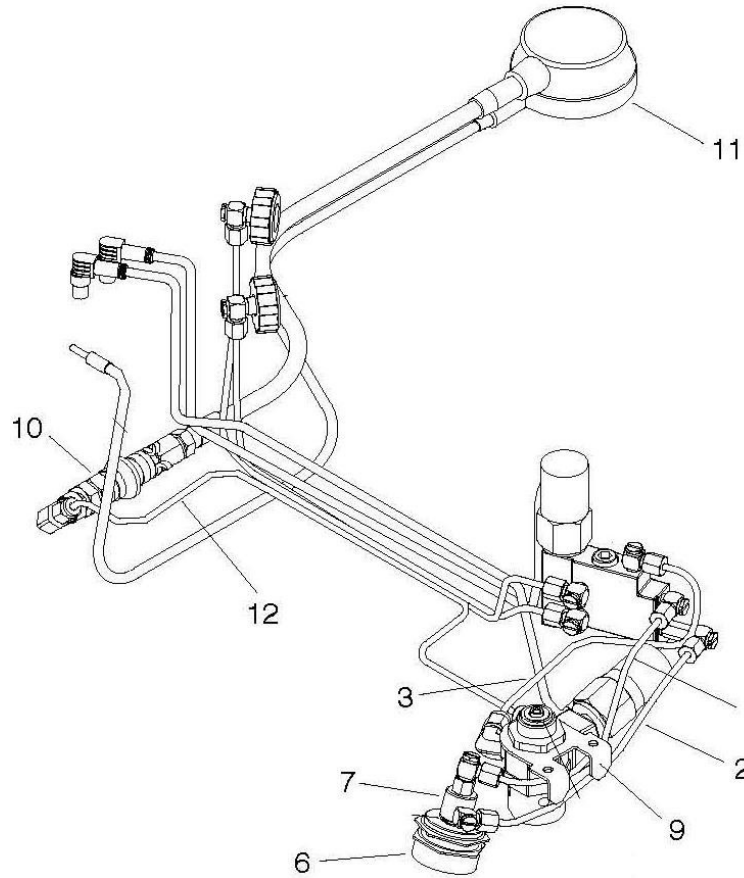

1 Cons. No.	2 Designation	1 Cons. No.	2 Designation
1	Bypass Feed Tube	9	Oxygen Regulator Assembly
2	Bypass Return Tube	10	Remote Gauge Shut Off Assembly
3	Oxygen Feed Tube	11	Remote Gauge Assembly
6	Bypass Valve Push Button	12	Remote Gauge Feed Tube Assembly
7	Bypass Valve		

Manifold Assembly

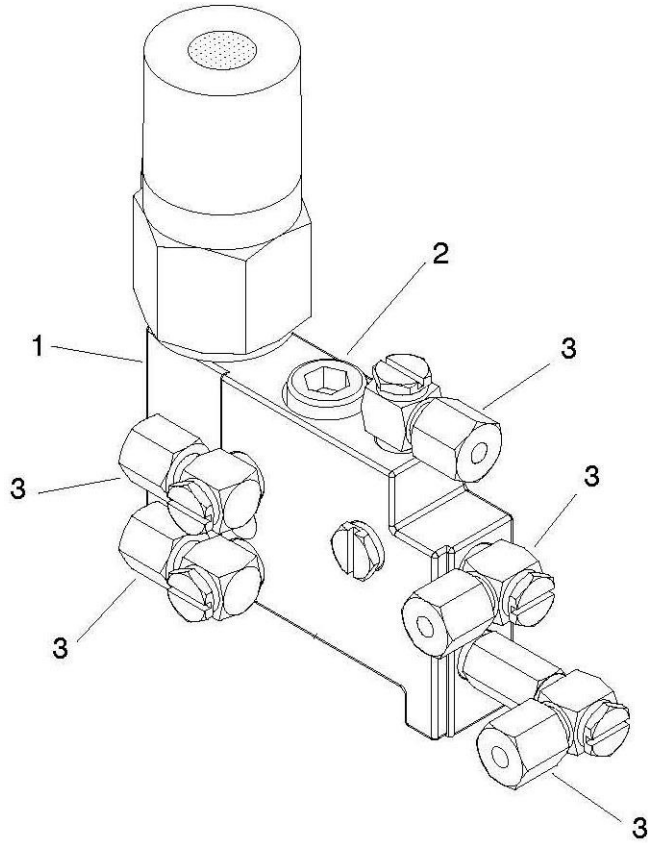

1 Cons. No.	2 Designation	1 Cons. No.	2 Designation
1	Manifold Block w/Pressure Switch	3	Swivel Elbow Fitting
2	Constant Add Flow Restrictor Assembly		

Center Section Assembly

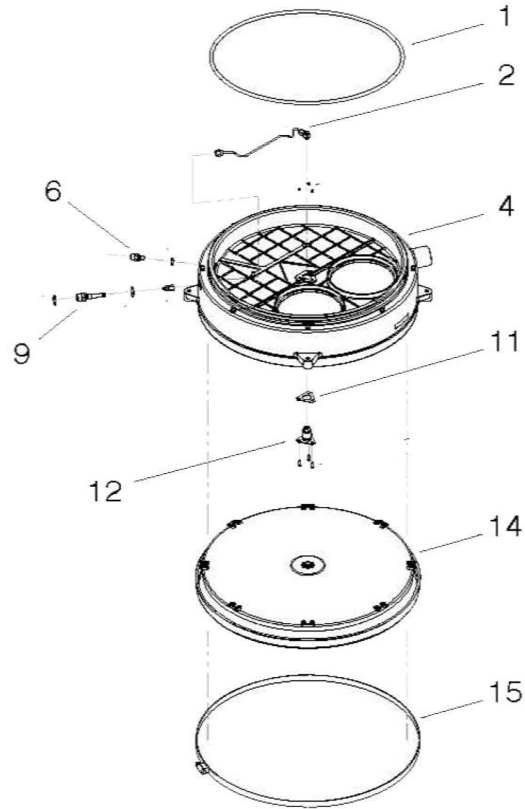

1 Cons. No.	2 Designation	1 Cons. No.	2 Designation
1	Lid O-Ring	11	Demand Valve Gasket
2	Demand Feed Tube	12	Demand Valve Assembly
4	Center Section Body Assembly	14	Flexible Diaphragm
6	Constant Add Fitting	15	Diaphragm Clamp
9	Demand Add Fitting		

Center Section Lid Assembly

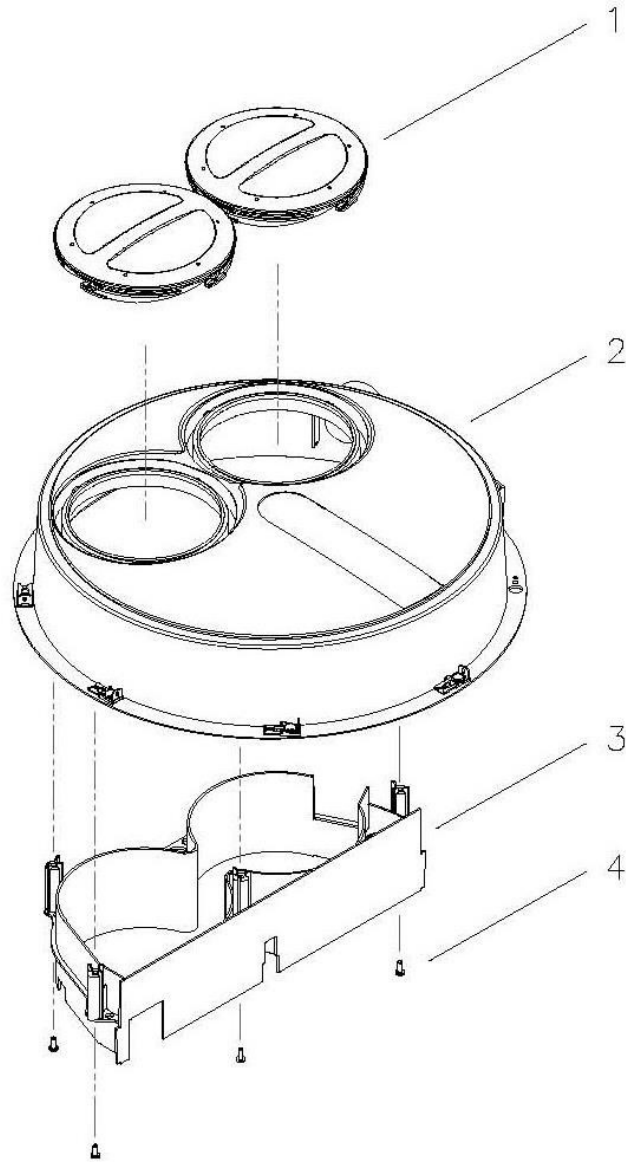

1 Cons. No.	2 Designation	1 Cons. No.	2 Designation
1	Coolant Lid	3	Flow Baffle
2	Center Section Lid	4	Self-Tapping Screws

Diaphragm Assembly

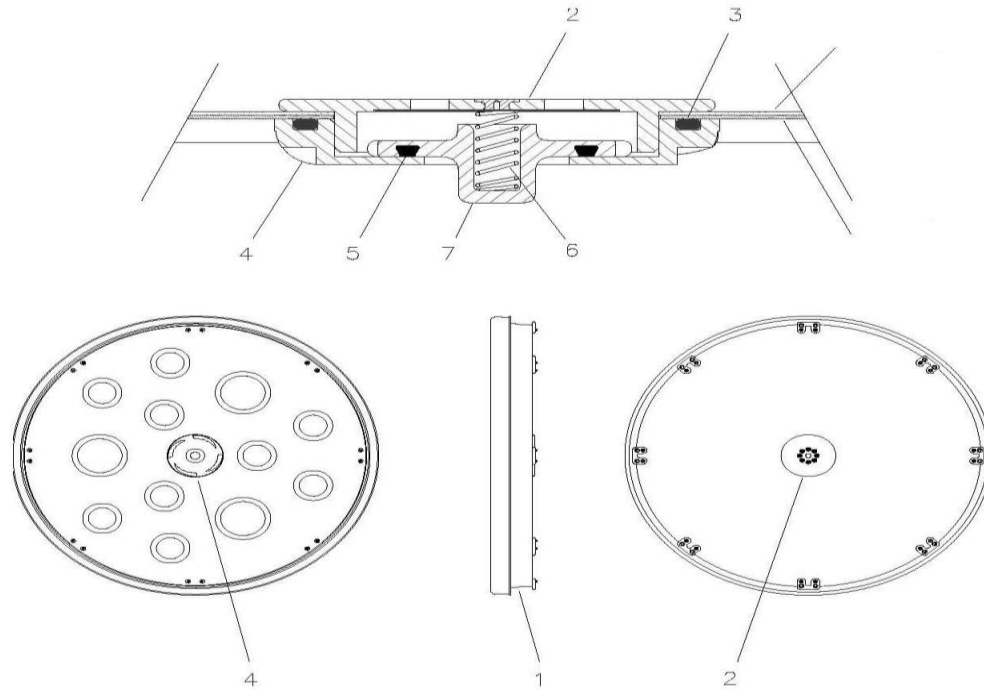

1 Cons. No.	2 Designation	1 Cons. No.	2 Designation
1	Flexible Diaphragm	5	Vent Seat O-Ring
2	Vent Cap	6	Vent Valve Spring
3	Vent Body O-Ring	7	Vent Valve Seat
4	Vent Body		

Breathing Hose

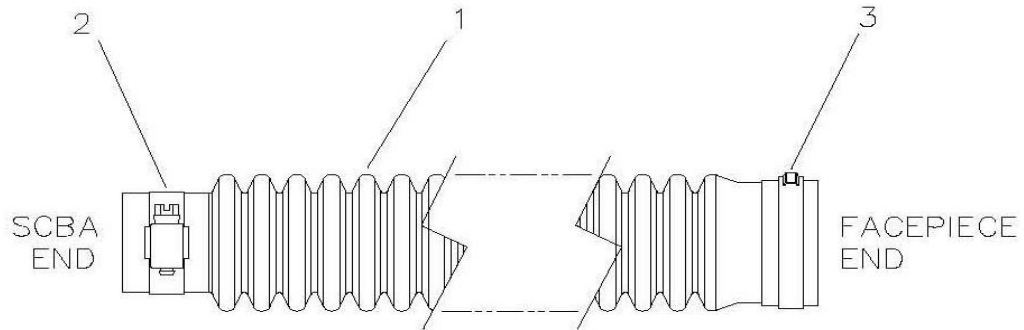

1 Cons. No.	2 Designation	1 Cons. No.	2 Designation
1	Breathing Hose	3	Stepless Ear Clamp
2	Worm Gear Hose Clamp		

Ice Canister Freeze Form

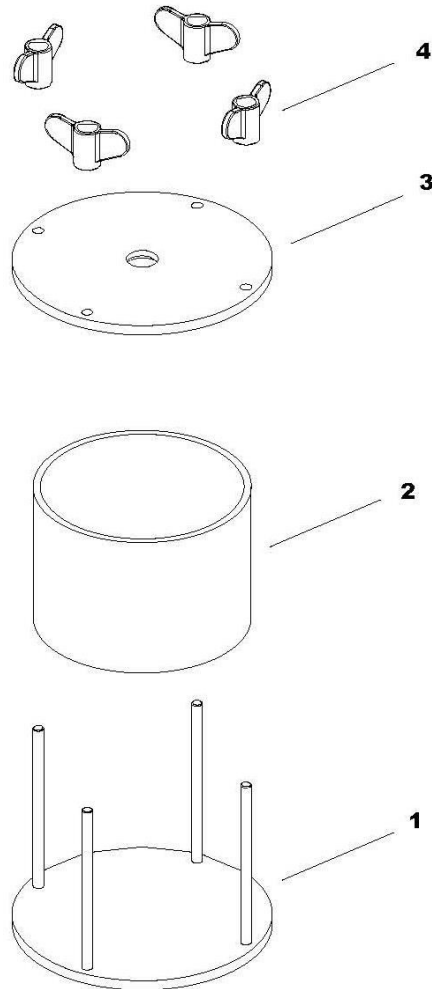

1 Cons. No.	2 Designation	1 Cons. No.	2 Designation
1	Base Assembly	3	Top Plate
2	Freeze Tube	4	Wing Nut

Oxygen Cylinder Assembly

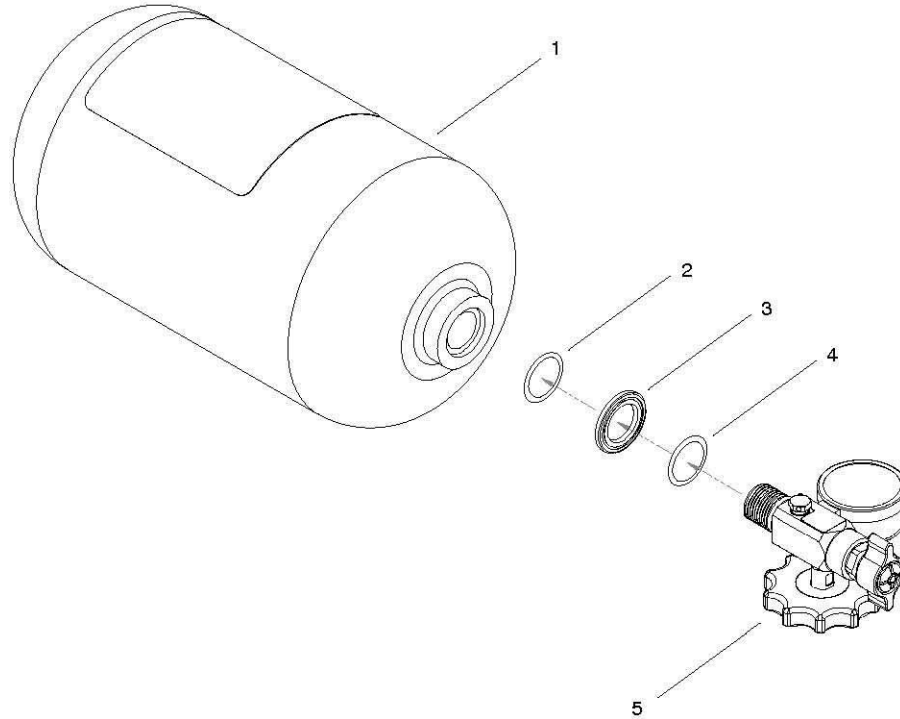

1 Cons. No.	2 Designation	1 Cons. No.	2 Designation
1	Green Cylinder	4	Interior O-Ring
2	Exterior O-Ring	5	Valve Assembly
3	Valve Collar		

RMS Monitoring System

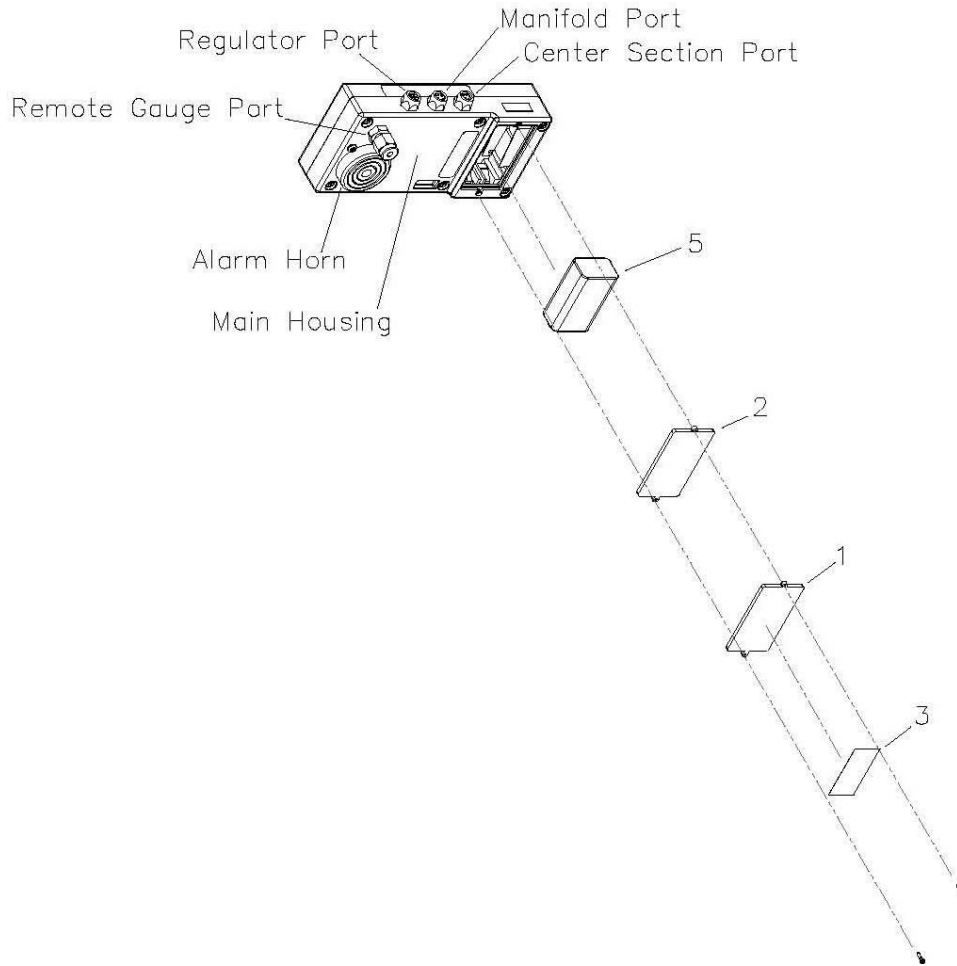

1 Cons. No.	2 Designation	1 Cons. No.	2 Designation
1	Battery Door	3	Battery Door Warning Label
2	Battery Door Gasket	5	9Vdc Battery

AV3500 Facemask-Complete

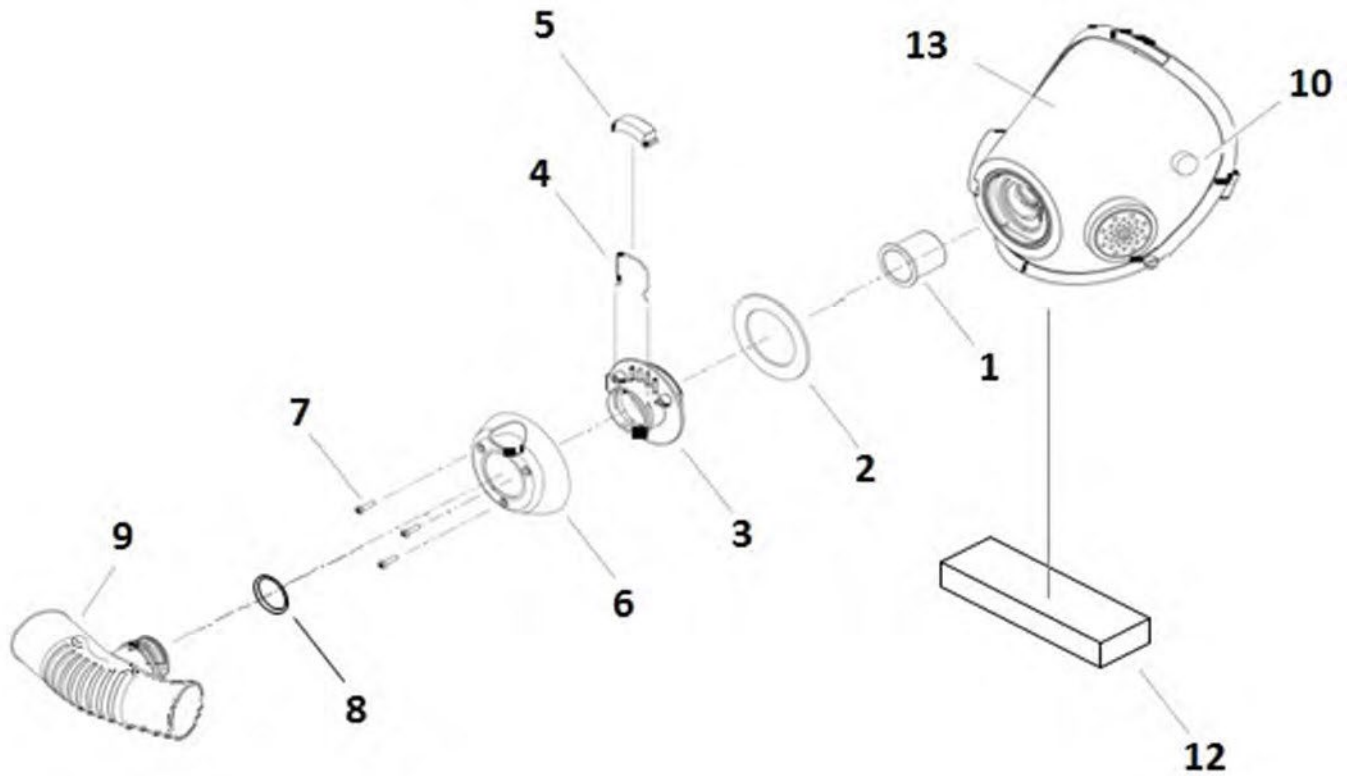

1 Cons. No.	2 Designation	1 Cons. No.	2 Designation
1	Interface Tube	7	Locking Pan Head Screw
2	Interface Gasket	8	Hose Adapter O-Ring
3	Interface Fitting	9	AV3500 Hose Adapter
4	Clip	10	Facemask Magnetic Wiper
5	Button	12	Chin Condensation Pad
6	Cowling	13	Lens

Tool Kit

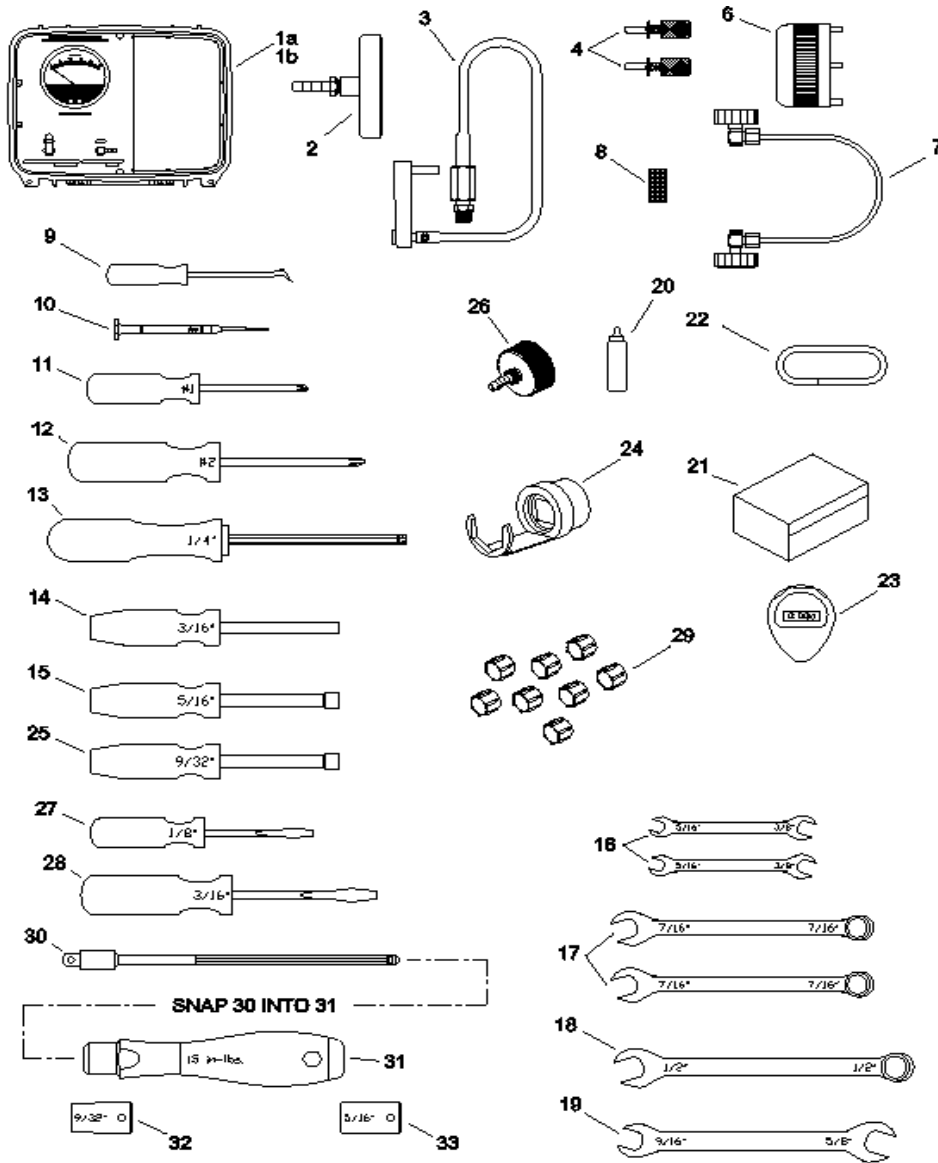

1 Cons. No.	2 Designation	1 Cons. No.	2 Designation
1	Case Assembly	7	Center Section Pneumatic Plug
26	Leak Check Adapter Fitting	9	Combination Pick Tool
3	Flow Test Fixture	13	1/4 - Inch Hex Driver
4	Test Key	20	Leak Detection Fluid
6	Vent Valve Wrench	22	3/8 - Inch OD Rubber Tubing